

Outline Dimensions

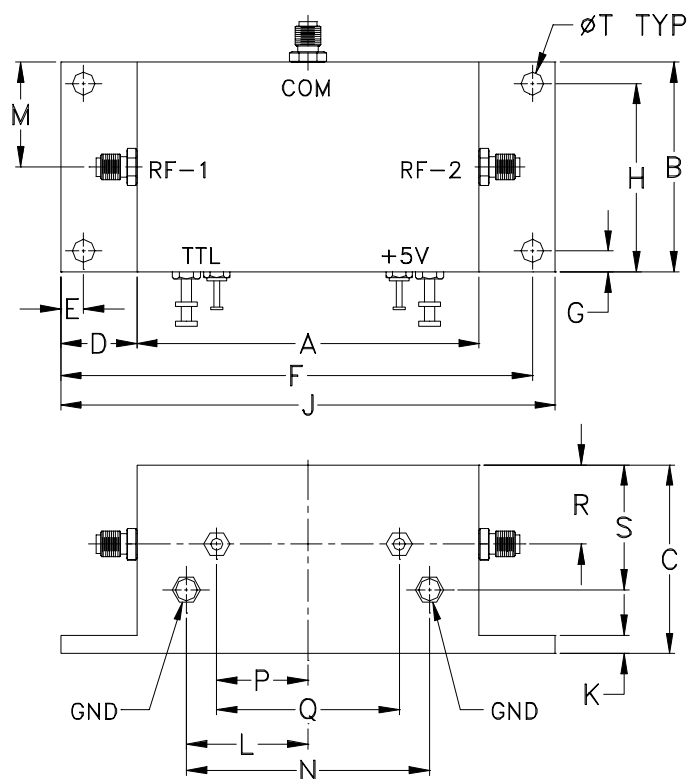

CASE#	A	B	C	D	E	F	G	H	J	K	L	M	N
CCC127	2.25 (57.15)	1.38 (35.05)	1.24 (31.50)	.50 (12.70)	.150 (3.81)	3.100 (78.74)	.138 (3.51)	1.238 (31.45)	3.25 (82.55)	.12 (3.05)	.80 (20.32)	.69 (17.53)	1.60 (40.64)

CASE#	P	Q	R	S	T	WT. GRAMS
CCC127	.60 (15.24)	1.200 (30.48)	.52 (13.21)	.82 (20.83)	.150 (3.81)	80.0

Dimensions are in inches (mm). Tolerances: 2 Pl. $\pm .03$; 3 Pl. $\pm .015$

Notes:

1. Case material: Aluminum alloy.
2. Case finish:

For RoHS Case Styles:

Clear chemical conversion coating, non-chrome or trivalent chrome based.



INTERNET <http://www.minicircuits.com>

P.O. Box 350166, Brooklyn, New York 11235-0003 (718) 934-4500 Fax (718) 332-4661

Distribution Centers NORTH AMERICA 800-654-7949 • 417-335-5935 • Fax 417-335-5945 • EUROPE 44-1252-832600 • Fax 44-1252-837010

Mini-Circuits ISO 9001 & ISO 14001 Certified