

# Case Style

# QV

## Outline Dimensions

## QV2426

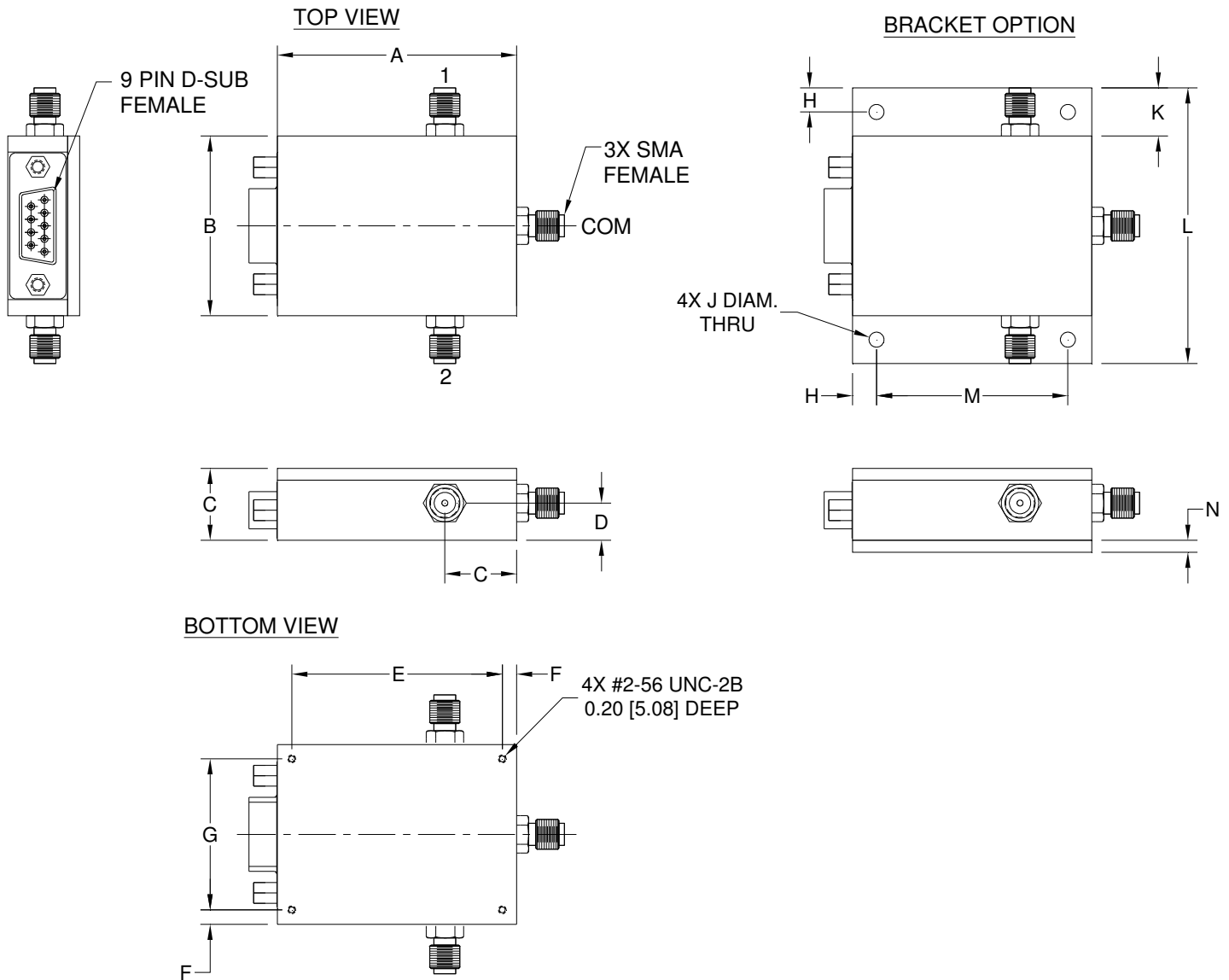

CASE#	A	B	C	D	E	F	G	H	J	K	L	M	N	WT. GRAMS
QV2426	2.00 (50.8)	1.50 (38.1)	.60 (15.24)	.31 (7.87)	1.760 (44.7)	.120 (3.05)	1.260 (32.0)	.200 (5.08)	.125 (3.18)	.40 (10.16)	2.30 (58.4)	1.600 (40.64)	.100 (2.54)	65

Dimensions are in inches (mm). Tolerances: 2PL. +/- .03; 3PL. +/- .015

### Notes:

1. Case material: Aluminum alloy.
2. Case finish for RoHS Case Styles: Clear chemical conversion coating, non-chrome or trivalent chrome based.

**Mini-Circuits**<sup>®</sup>

INTERNET <http://www.minicircuits.com>

P.O. Box 350166, Brooklyn, New York 11235-0003 (718) 934-4500 Fax (718) 332-4661

Distribution Centers NORTH AMERICA 800-654-7949 • 417-335-5935 • Fax 417-335-5945 • EUROPE 44-1252-832600 • Fax 44-1252-837010

Mini-Circuits ISO 9001 & ISO 14001 Certified