

Evaluation Board and Circuit

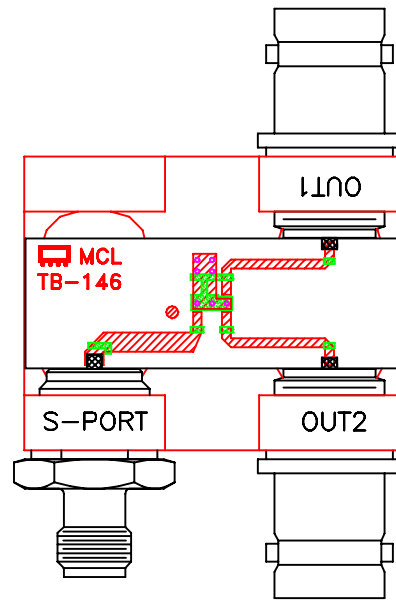

TB-146

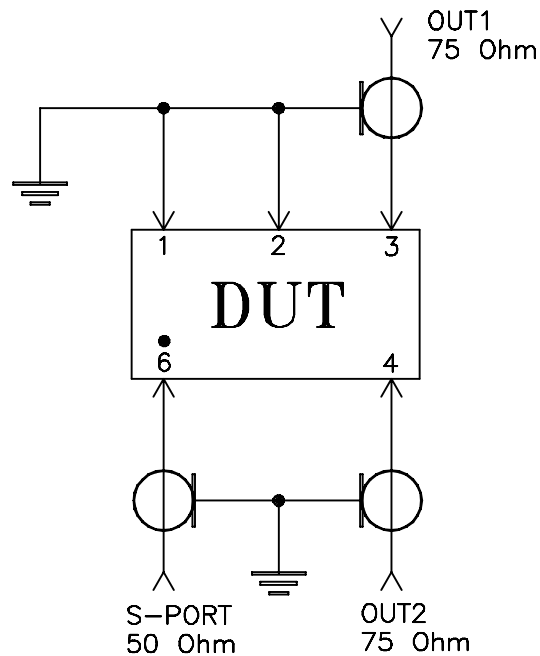

Schematic Diagram

Notes:

1. 50 Ohm SMA AND 75 Ohm BNC Female connectors.
2. PCB Material: Rogers R04350 or equivalent,
Dielectric Constant=3.5, Thickness=.030 inch.

 Mini-Circuits®