

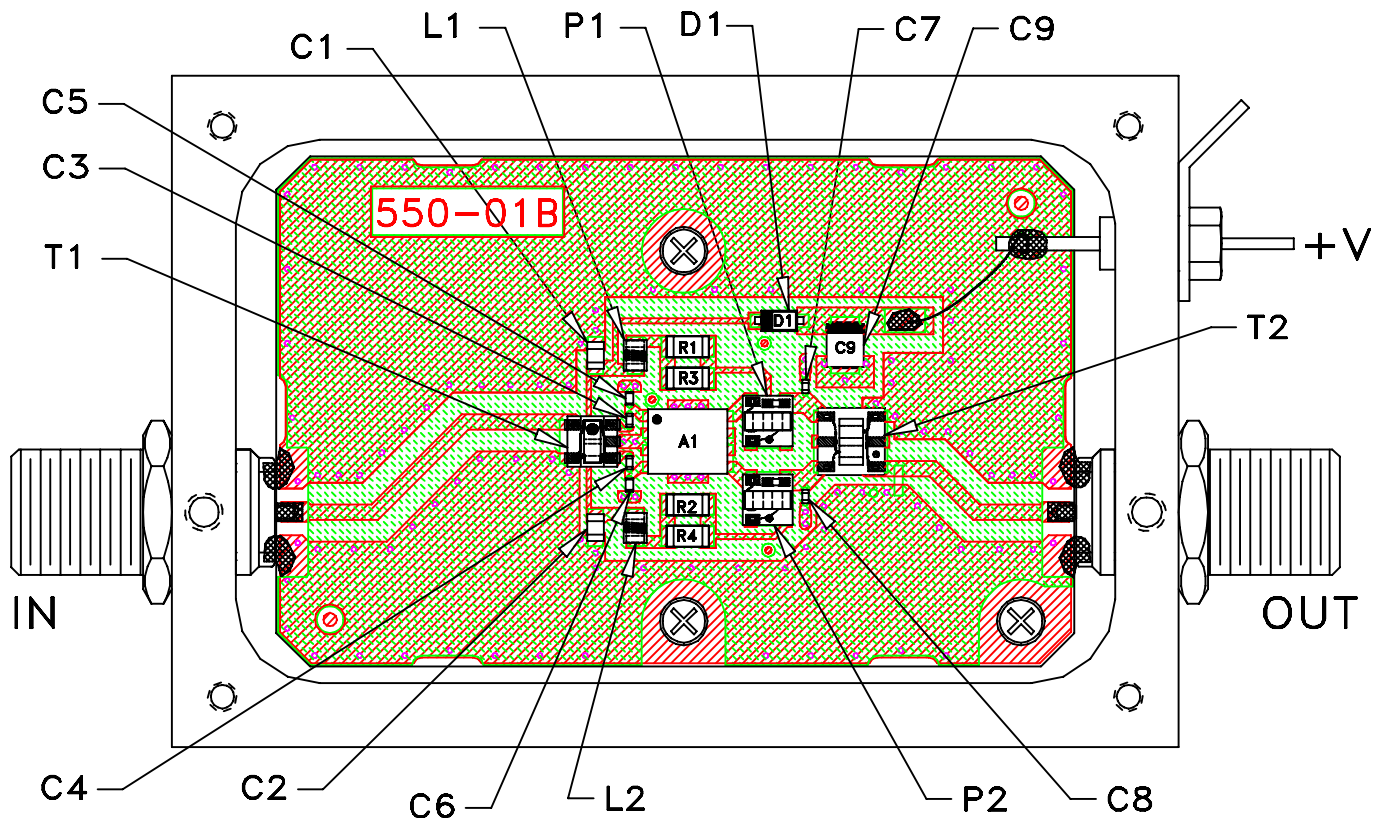

Evaluation Board and Circuit



TB-566-75-11+

Notes:

1. 75 Ohm F Female connectors.
2. PCB Material: FR4.
Dielectric Constant=4.7, Thickness=.059 inch.

 **Mini-Circuits®**

Evaluation Board and Circuit

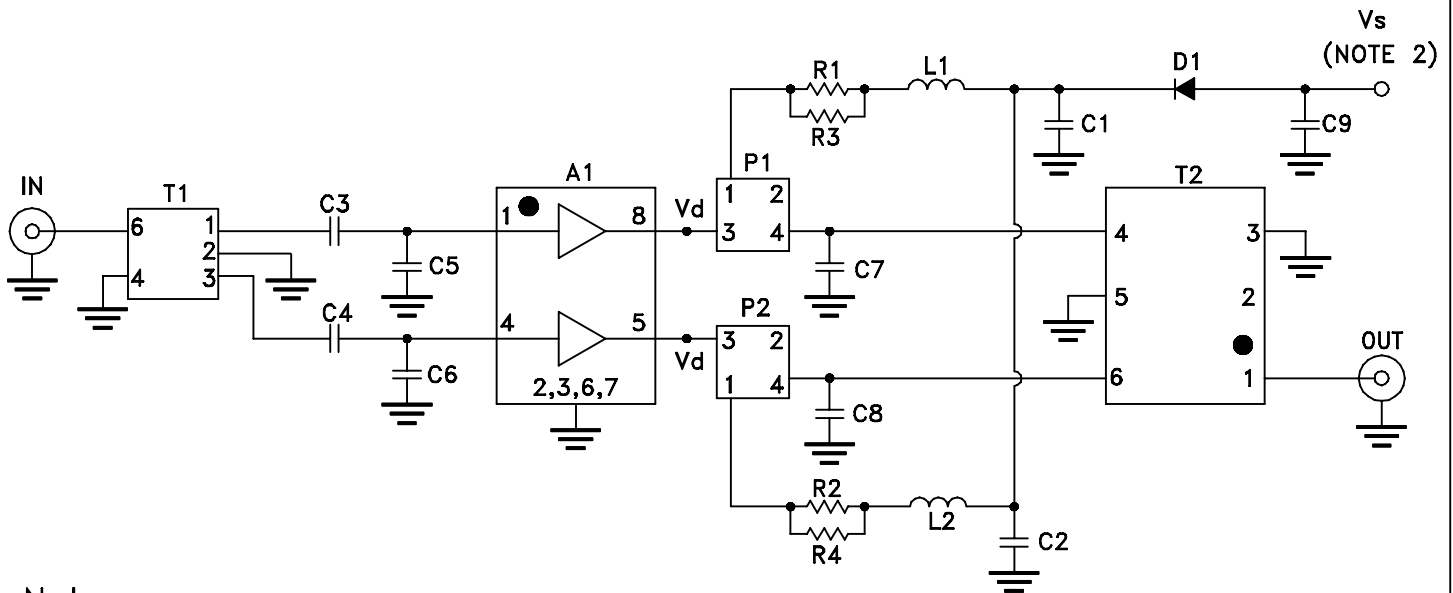

Note:

1. Numbers inside the boxes indicate Pin Numbers.
2. Set V_s to obtain $V_d = +5V$.

COMPONENT	VALUE
A1	Mini-Circuits PHA-11+
C1,C2	.039 μ F
C3,C4	1000 pF
C5,C6	.75 pF
C7,C8	1.6 pF
C9	1.0 μ F
D1	ON Semiconductor: MBR0520LT1G
L1,L2	680 nH
P1,P2	Mini-Circuits TCBT-6G+
R1,R2	11.5 Ohm
R3,R4	7.50 Ohm
T1	Mini-Circuits TC1.33-282+
T2	Mini-Circuits TRS1-23-75+

Schematic Diagram

 Mini-Circuits®