

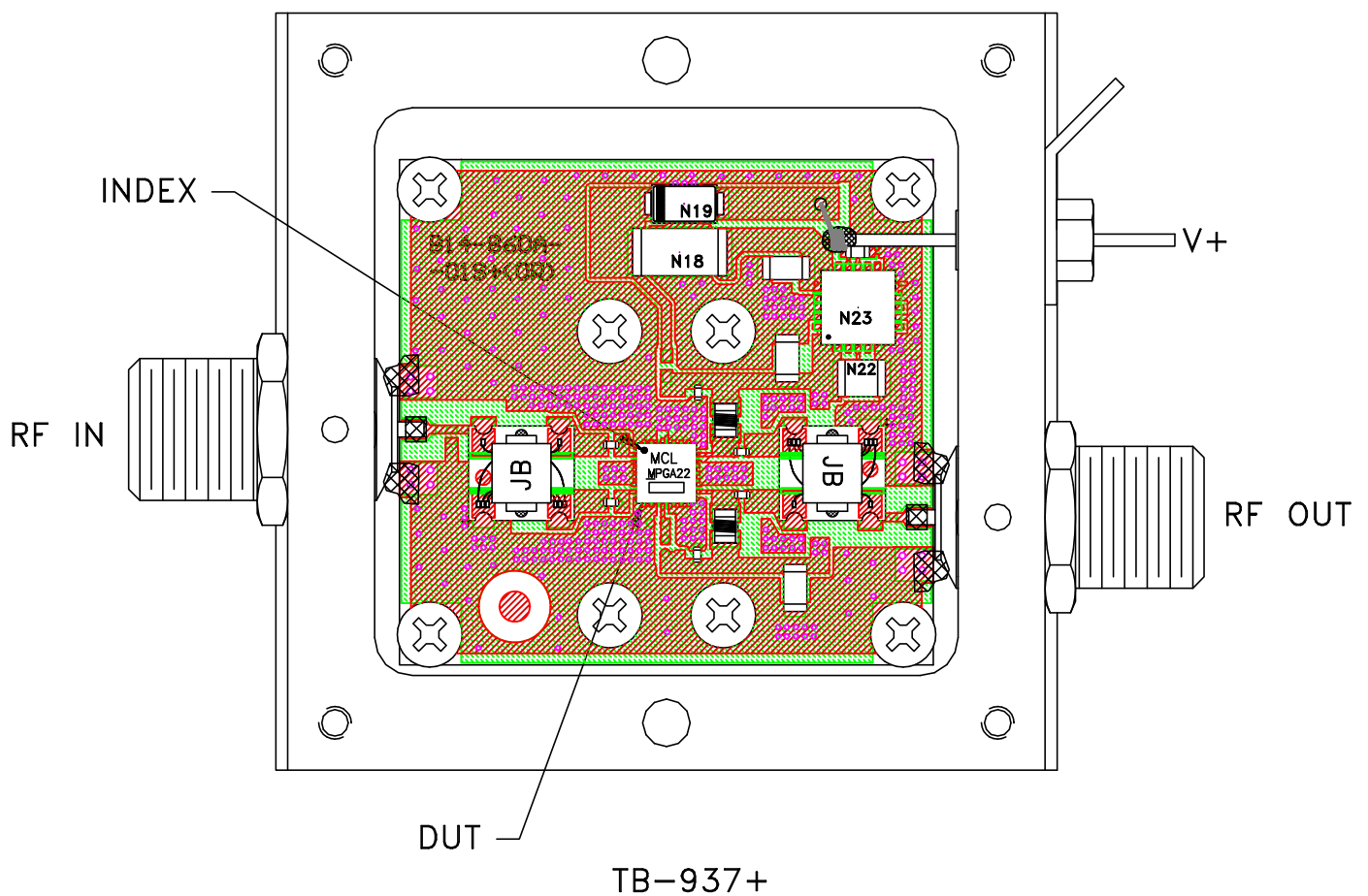

Evaluation Board and Circuit



STACK-UP DIAGRAM

Notes:

1. 75 Ohm F-Type Female connectors.
 2. PCB Material: FR4 or equivalent, Dielectric Constant=4.5.
- Total Finished Thickness - .024".

 **Mini-Circuits®**

Evaluation Board and Circuit

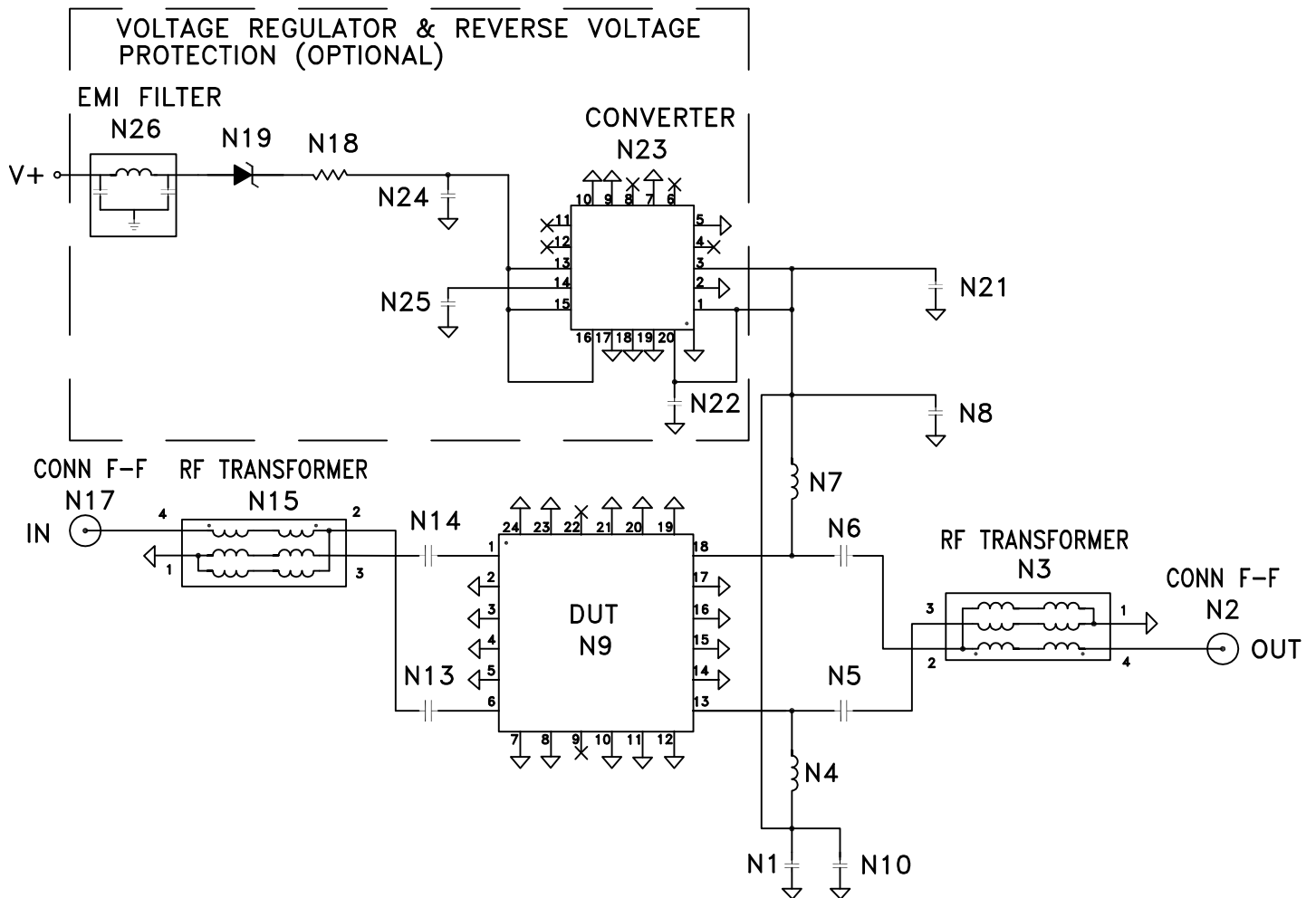

COMPONENT	VALUE	SIZE
N9 (DUT)	Mini-Circuits MPGA-122-75+	4X4 mm
N1,N21,N24	Capacitor 10 uF	1206
N3,N15	Mini-Circuits TRS1-182-75+	7.11X6.35 mm
N4,N7	Inductor 390 nH	0805
N5,N6,N13,N14	Capacitor 220 pF	0402
N8,N10	Capacitor .01 uF	
N18	Resistor 4.32 Ohms,1W	2512
N19	Diode Schottky SMA 40V MSL1	5.21X2.60 mm
N22	Capacitor 22 uF	1210
N23	Voltage Regulator QFN20 ADJ MSL2	5X5 mm
N25	Capacitor 1 uF	0603
N26	EMI Filter	-

Schematic Diagram