

# Evaluation Board and Circuit

SEE DETAIL "A"

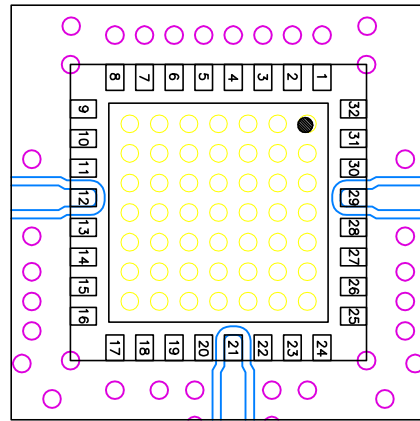

DETAIL "A"  
(SCALE 5:1)

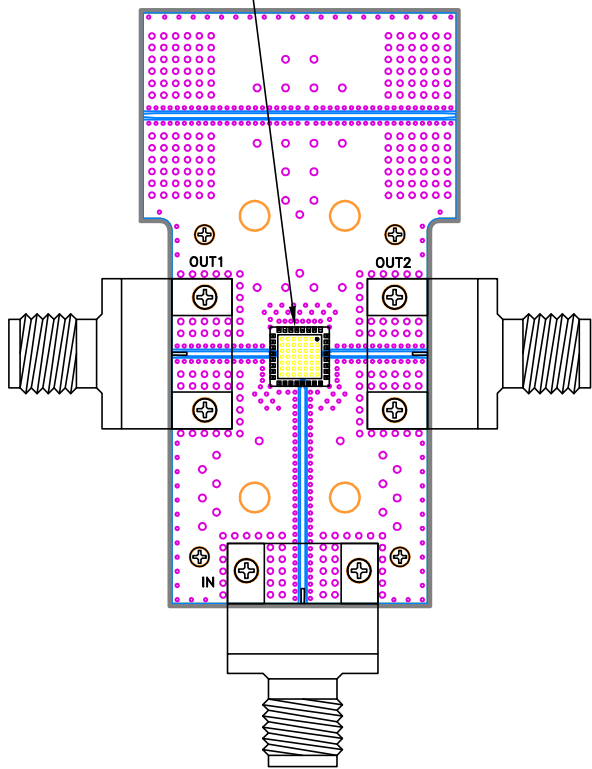
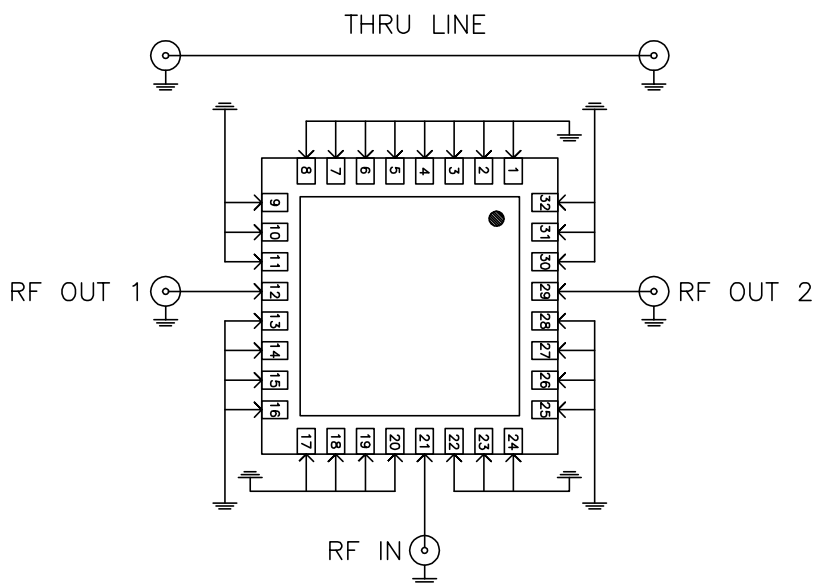

SCHEMATIC DIAGRAM  
(SCALE 5:1)

## Notes:

1. 2.92mm Female Connectors.
2. PCB Material: Roger R04350B or equivalent,  
Dielectric constant=3.5, Thickness=0.010 inch

 **Mini-Circuits®**