

# Evaluation Board and Circuit

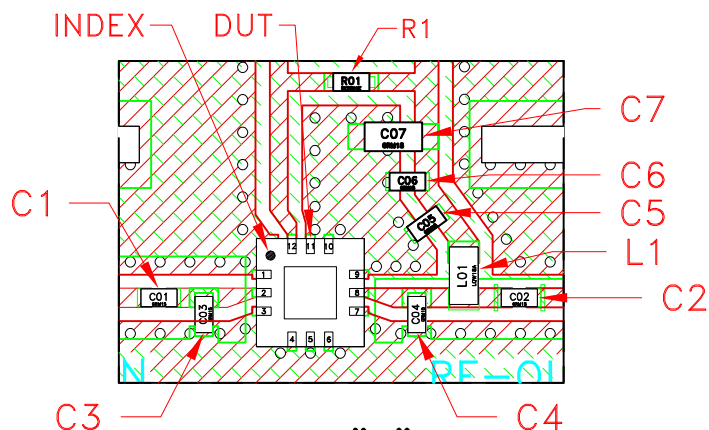

DETAIL "A"  
LOCATION OF COMPONENTS  
ON THE PCB  
(SCALE 3:1)

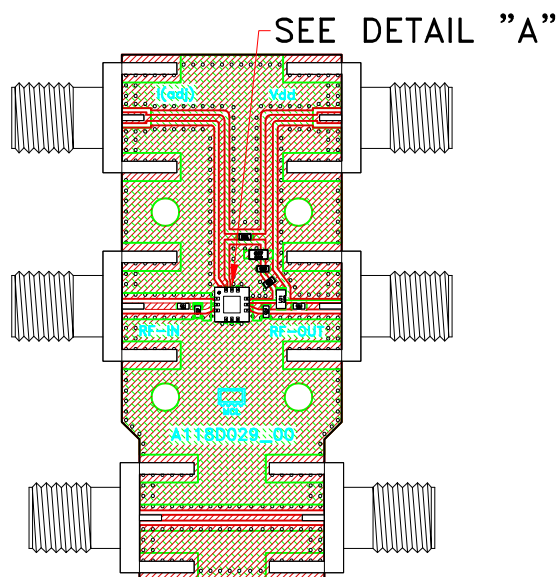
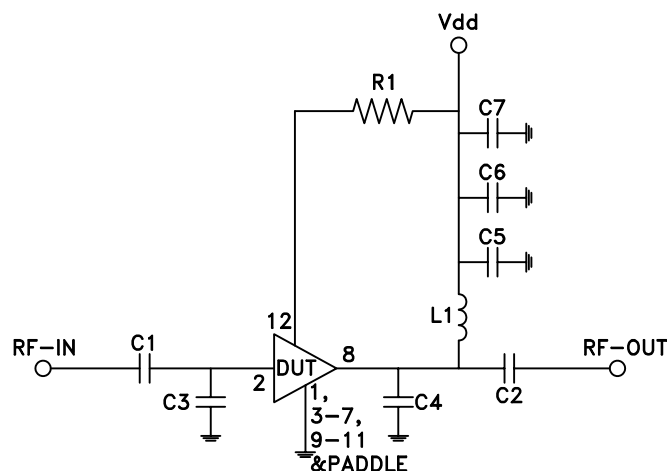

SCHEMATIC DIAGRAM

Component	Size	Value	Part Number	Manufacturer
C1,C2	0402	100pF	GRM1555C1H101JA01D	Murata
C3	0402	0.4pF	GJM1555C1HR40WB01D	Murata
C4	0402	0.1pF	GJM1555C1HR10WB01D	Murata
C5	0402	10pF	GRM1555C1H100JA01D	Murata
C6	0402	1uF	GRM155C71A105KE11D	Murata
C7	0603	10uF	GRM188D71A106MA73J	Murata
L1	0603	33nH	0603CS-33NXJEW	Coilcraft
R1	0402	2.2KOhm	RK73H1ETTP2201F	KOA Speer

## Notes:

1. 50 Ohm SMA Female Connectors.
2. PCB Material: Roger R04350B or equivalent,  
Dielectric constant=3.5, Thickness=0.010 inch

 Mini-Circuits®