

# Surface Mount Bandpass Filter

## CBP-1170C+

50Ω 1110 to 1230 MHz

### The Big Deal

- Excellent Rejection
- Low passband Insertion Loss
- Miniature shielded package

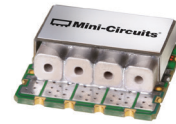

Generic photo used for illustration purposes only  
CASE STYLE: MP1766

### Product Overview

CBP-1170C+ is a ceramic-coaxial-resonator based bandpass filter in a shielded package fabricated using SMT technology. This filter offers outstanding close in rejection, low insertion loss and high power handling for use in aviation, mobile radio, broadband and fixed wireless.

### Key Features

Feature	Advantages
High Selectivity	The CBP-1170C+ filter incorporates High-Q ceramic resonators that enables sharp rejection near passband.
Low Passband VSWR	This filter maintains typical VSWR over passband frequency range making this filter easier to integrate into receiver and transmitter RF chains with less concerns for in band frequency ripple.
Rugged construction	The CBP-1170C+ has been qualified over wide range of thermal, mechanical and environmental conditions including withstanding the stress of extensive solder reflow cycles.

#### Notes

- A. Performance and quality attributes and conditions not expressly stated in this specification document are intended to be excluded and do not form a part of this specification document.  
B. Electrical specifications and performance data contained in this specification document are based on Mini-Circuit's applicable established test performance criteria and measurement instructions.  
C. The parts covered by this specification document are subject to Mini-Circuits standard limited warranty and terms and conditions (collectively, "Standard Terms"); Purchasers of this part are entitled to the rights and benefits contained therein. For a full statement of the Standard Terms and the exclusive rights and remedies thereunder, please visit Mini-Circuits' website at [www.minicircuits.com/MCLStore/terms.jsp](http://www.minicircuits.com/MCLStore/terms.jsp)



# Surface Mount Bandpass Filter

## CBP-1170C+

50Ω 1110 to 1230 MHz

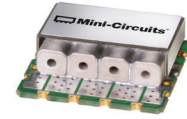

Generic photo used for illustration purposes only  
CASE STYLE: MP1766

### Features

- Low Insertion loss
- High selectivity
- Miniature shielded package

### Electrical Specifications at 25°C

Parameter		F#	Frequency (MHz)	Min.	Typ.	Max.	Unit
Pass Band	Center Frequency	—	—	—	1170	—	MHz
	Insertion Loss	F1-F2	1110-1230	—	0.6	2	dB
	VSWR	F1-F2	1110-1230	—	1.4	—	:1
Stop Band, Lower	Insertion Loss	DC-F3	DC-900	20	30	—	dB
	VSWR	DC-F3	DC-900	—	20	—	:1
Stop Band, Upper	Insertion Loss	F4-F5	1560-2200	20	29	—	dB
	VSWR	F4-F5	1560-2200	—	20	—	:1

### Applications

- Traffic collision avoidance system (TCAS)
- Aeronautical radio navigation
- Fixed satellite
- Radio astronomy
- Radar and navigation system

### Functional Schematic

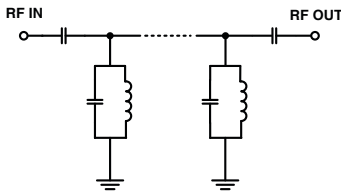

Maximum Ratings	
Operating Temperature	-40°C to 85°C
Storage Temperature	-55°C to 100°C
RF Power Input	5W

Permanent damage may occur if any of these limits are exceeded.

### Typical Performance Data at 25°C

Frequency (MHz)	Insertion Loss (dB)	VSWR (:1)	Frequency (MHz)	Group Delay (nsec)
1	62.90	347.44	1110	3.61
810	51.32	64.35	1116	3.53
900	33.11	51.10	1120	3.47
960	19.64	36.97	1124	3.43
995	10.97	18.11	1128	3.38
1020	5.18	6.71	1132	3.34
1040	2.20	2.88	1136	3.29
1060	1.01	1.62	1140	3.26
1110	0.56	1.05	1144	3.23
1170	0.51	1.11	1148	3.20
1230	0.52	1.07	1152	3.17
1284	1.38	2.28	1156	3.14
1316	3.83	5.58	1160	3.12
1345	7.27	12.89	1166	3.10
1405	14.77	41.37	1170	3.08
1560	30.45	69.49	1180	3.05
1665	40.78	72.39	1190	3.03
1950	51.22	75.53	1200	3.01
2100	56.87	82.73	1220	3.06
2200	66.27	86.86	1230	3.14

### Typical Frequency Response

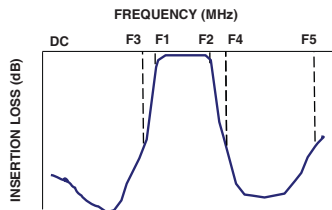

**+RoHS Compliant**  
The +Suffix identifies RoHS Compliance. See our web site for RoHS Compliance methodologies and qualifications

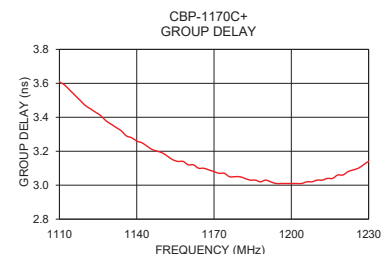
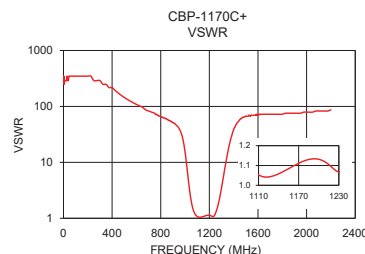
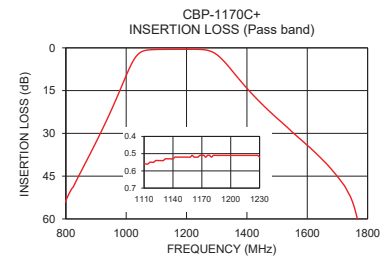
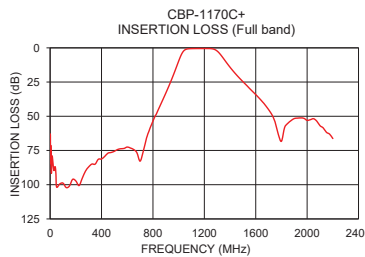

### Notes

- Performance and quality attributes and conditions not expressly stated in this specification document are intended to be excluded and do not form a part of this specification document.
- Electrical specifications and performance data contained in this specification document are based on Mini-Circuit's applicable established test performance criteria and measurement instructions.
- The parts covered by this specification document are subject to Mini-Circuits standard limited warranty and terms and conditions (collectively, "Standard Terms"); Purchasers of this part are entitled to the rights and benefits contained therein. For a full statement of the Standard Terms and the exclusive rights and remedies thereunder, please visit Mini-Circuits' website at [www.minicircuits.com/MCLStore/terms.jsp](http://www.minicircuits.com/MCLStore/terms.jsp)



[www.minicircuits.com](http://www.minicircuits.com) P.O. Box 350166, Brooklyn, NY 11235-0003 (718) 934-4500 sales@minicircuits.com

REV.B  
M174392  
CBP-1170C+  
EDU1836  
URJ  
200810  
Page 2 of 3

## Pad Connections

INPUT	1
OUTPUT	10
GROUND	2,3,4,5,6,7,8,9,11,12,13

**Demo Board MCL P/N: TB-684+**  
**Suggested PCB Layout (PL-373)**

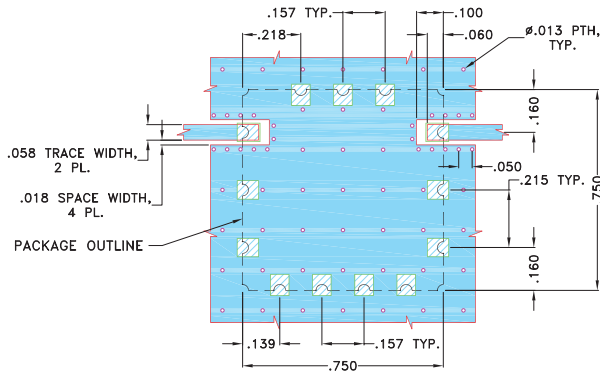

### NOTES:

- TRACE WIDTH IS SHOWN FOR OAK (OAK-602) WITH DIELECTRIC THICKNESS .022"±.0015". COPPER: 1/2 OZ. EACH SIDE. FOR OTHER MATERIALS TRACE WIDTH MAY NEED TO BE MODIFIED.
- BOTTOM SIDE OF THE PCB IS CONTINUOUS GROUND PLANE.

- DENOTES PCB COPPER LAYOUT WITH SMOBC (SOLDER MASK OVER BARE COPPER)
- DENOTES COPPER LAND PATTERN FREE OF SOLDERMASK

## Outline Drawing

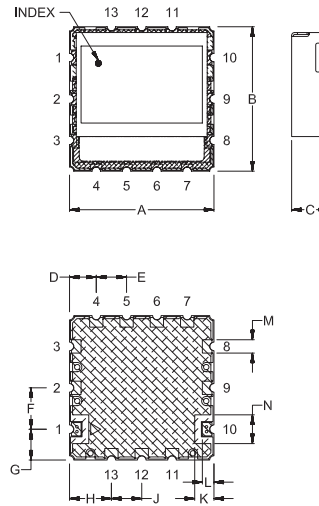

## PCB Land Pattern

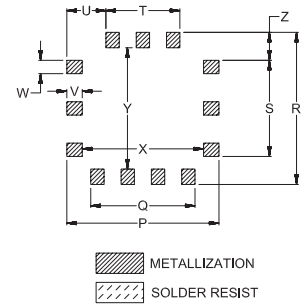

## Outline Dimensions (inch/mm)

A	B	C	D	E	F	G	H	J	K	L	M	N
.750	.750	.210	.139	.157	.215	.160	.218	.157	.100	.060	.069	.149
19.05	19.05	5.33	3.53	3.99	5.46	4.06	5.54	3.99	2.54	1.52	1.75	3.78
P	Q	R	S	T	U	V	W	X	Y	Z	wt.	
.790	.541	.790	.499	.384	.203	.080	.069	.630	.630	.145		grams
20.07	13.74	20.07	12.67	9.75	5.16	2.03	1.75	16.00	16.00	3.68		4.6

*Note: Please refer to case style drawing for details*

### Notes

- A. Performance and quality attributes and conditions not expressly stated in this specification document are intended to be excluded and do not form a part of this specification document.
- B. Electrical specifications and performance data contained in this specification document are based on Mini-Circuit's applicable established test performance criteria and measurement instructions.
- C. The parts covered by this specification document are subject to Mini-Circuits standard limited warranty and terms and conditions (collectively, "Standard Terms"); Purchasers of this part are entitled to the rights and benefits contained therein. For a full statement of the Standard Terms and the exclusive rights and remedies thereunder, please visit Mini-Circuits' website at [www.minicircuits.com/MCLStore/terms.jsp](http://www.minicircuits.com/MCLStore/terms.jsp)