



CERAMIC

Power Splitter / Combiner

SCG-3-752+

3 Way-0° 50Ω 4500 to 7500 MHz

THE BIG DEAL

- Isolation resistor, external 150 ohms
- Low insertion loss, 1.3 dB typ.
- Excellent phase unbalance, 5 deg. typ.
- Wrap around terminations for excellent solderability



Generic photo used for illustration purposes only

CASE STYLE: GE0805C-1

APPLICATIONS

- WIFI6
- 5G sub 6GHz

+RoHS Compliant

The +Suffix identifies RoHS Compliance. See our website for methodologies and qualifications

PRODUCT OVERVIEW

Mini-Circuits new LTCC 0° Power Splitter, model SCG-3-752+, offers industry leading combination of operating performance and size.

KEY FEATURES

Features	Advantages
Small Size	Offered in the package size, SCG-3-752+ offers an industry leading combination of size, power handling, and frequency. The small footprint allows for reduced parasitics in systems with improved performance and simplified layout.
Wrap-Around Terminations	Provides excellent solderability and easy visual inspection.
LTCC Construction	Provides repeatable performance in the rugged, ceramic package well suited for tough environments such as high humidity and temperature extremes.



CERAMIC

Power Splitter / Combiner

SCG-3-752+

Mini-Circuits

3 Way-0° 50Ω 4500 to 7500 MHz

ELECTRICAL SPECIFICATIONS¹ AT 25°C

Parameter	Frequency (MHz)	Min.	Typ.	Max.	Unit
Frequency Range		4500		7500	MHz
Average Insertion Loss, above 4.8 dB	4500 - 7500	—	1.3	2.1	dB
Isolation	4500 - 7500	11	14	—	dB
Phase Unbalance	4500 - 7500	—	5	10	Degree
Amplitude Unbalance	4500 - 7500	—	0.8	1.2	dB
Return Loss (Input)	4500 - 7500	—	10	—	dB
Return Loss (Output)	4500 - 7500	—	10	—	dB

Tested on TB-SCG-3-752+. Evaluation Board losses have been de-embedded.

MAXIMUM RATINGS

Parameter	Ratings
Operating Temperature	-55°C to 125°C
Storage Temperature	-55°C to 125°C
Input Power	2W* max.

Permanent damage may occur if any of these limits are exceeded.

ELECTRICAL SCHEMATIC

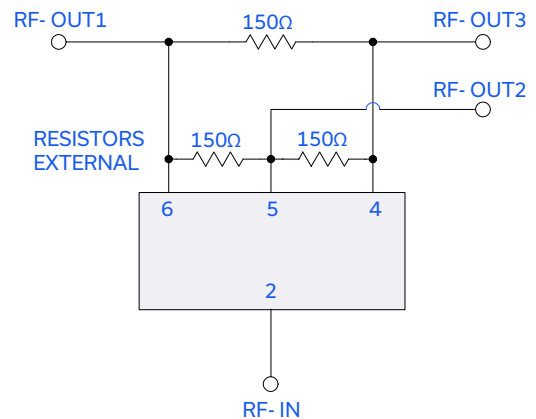



CERAMIC

Power Splitter / Combiner

SCG-3-752+

Mini-Circuits

3 Way-0° 50Ω 4500 to 7500 MHz

PAD CONNECTIONS



SUM PORT 2	2
PORT 1	6
PORT 2	5
PORT 3	4
GROUND	1,3
PORT 1-2, 2-3, 1-3	resistor external 150 ohms

PRODUCT MARKING: PT

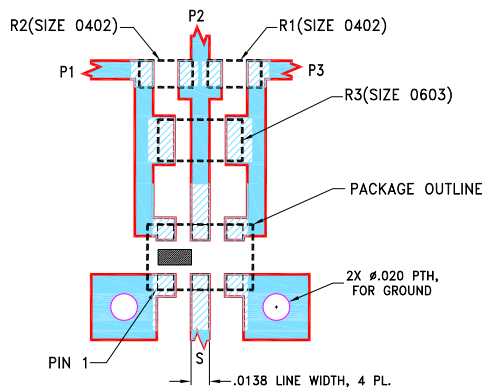
DEMO BOARD MCL P/N: TB-SCG-3-752+ SUGGESTED PCB LAYOUT (PL-621)



NOTES:

1. LINE WIDTH IS SHOWN FOR ROGERS R04350B WITH DIELECTRIC THICKNESS .0066±.0007. COPPER: 1/2 OZ. EACH SIDE. FOR OTHER MATERIALS LINE WIDTH MAY NEED TO BE MODIFIED.
 2. UNIT FOOT PRINT IS OPTIMIZED FOR PERFORMANCE AND IS DIFFERENT FROM CASE STYLE GE0805C-1 RECOMMENDATIONS.
 3. CHIP COMPONENT FOOT PRINT IS SHOWN FOR REFERENCE. FOR COMPONENT VALUE REFER TO TB-1018+.
 4. BOTTOM SIDE OF THE PCB IS CONTINUOUS GROUND PLANE.
-  DENOTES PCB COPPER LAYOUT WITH SMOBC (SOLDER MASK OVER BARE COPPER).
 DENOTES COPPER LAND PATTERN FREE OF SOLDER MASK.

OUTLINE DRAWING

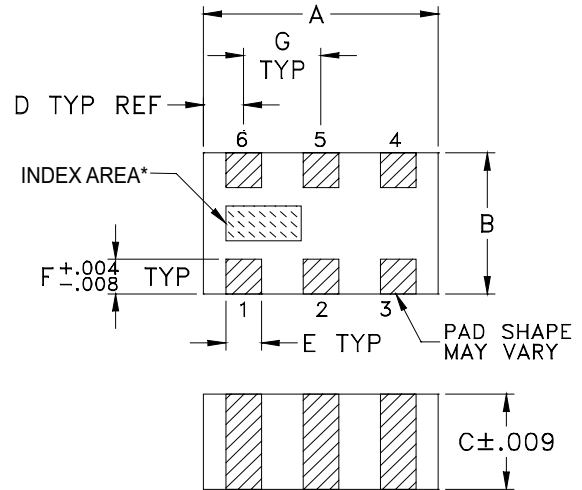

*Shape of index marking may vary

OUTLINE DIMENSIONS (Inch/mm)

A	B	C	D	E	F	G	wt
.079	.049	.033	.014	.012	.012	.026	grams
2.01	1.24	0.84	0.36	0.30	0.30	0.65	.008



CERAMIC

Power Splitter / Combiner

SCG-3-752+

Mini-Circuits

3 Way-0° 50Ω 4500 to 7500 MHz

TYPICAL PERFORMANCE DATA AND CHARTS

Frequency (MHz)	Total Loss ¹ (dB)			Amplitude Unbalance (dB)	Isolation (dB)			Phase Unbalance (deg.)	Return Loss (dB)			
	S-1	S-2	S-3		1-2	1-3	2-3		S	1	2	3
4500	5.96	5.84	5.91	0.12	13.78	14.30	13.75	2.77	8.50	29.80	17.44	31.74
4750	5.91	5.78	5.86	0.13	14.78	15.15	14.76	2.89	8.99	36.84	18.69	29.64
5000	5.86	5.72	5.82	0.15	15.96	16.14	15.95	2.95	9.51	34.52	20.01	25.68
5250	5.83	5.67	5.80	0.16	17.27	17.21	17.28	3.18	10.01	27.93	21.42	22.64
5500	5.77	5.60	5.76	0.17	18.88	18.49	18.90	3.40	10.67	24.45	22.98	20.62
5750	5.73	5.54	5.72	0.19	20.94	20.07	21.00	3.59	11.54	21.65	24.06	19.06
6000	5.68	5.47	5.68	0.21	23.70	22.04	23.79	3.85	12.72	19.75	24.97	17.65
6250	5.65	5.41	5.66	0.24	27.94	24.67	28.13	4.13	14.24	18.08	25.38	16.56
6500	5.63	5.38	5.65	0.27	35.49	27.81	36.13	4.38	15.87	16.65	24.67	15.56
6750	5.65	5.36	5.65	0.30	40.04	30.69	39.93	4.61	18.07	15.34	23.32	14.66
7000	5.70	5.37	5.69	0.33	29.04	29.26	28.83	4.85	19.29	14.08	21.59	13.81
7250	5.82	5.45	5.80	0.37	24.78	25.47	24.58	4.95	16.84	12.81	19.13	12.76
7500	6.03	5.61	5.97	0.42	22.01	22.30	21.80	5.11	13.58	11.54	16.71	11.67

1. Total Loss = Insertion Loss + 4.8dB splitter loss.

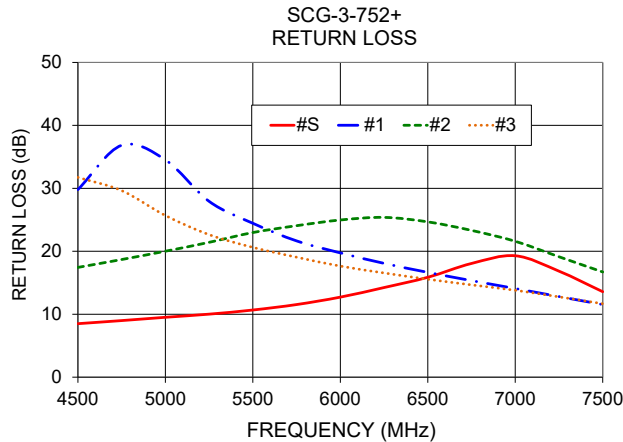
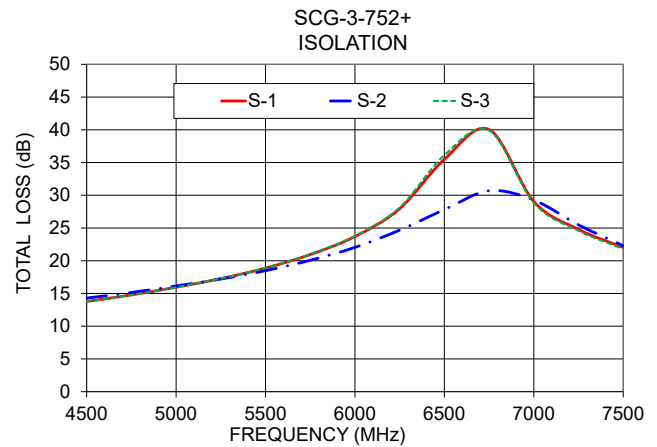
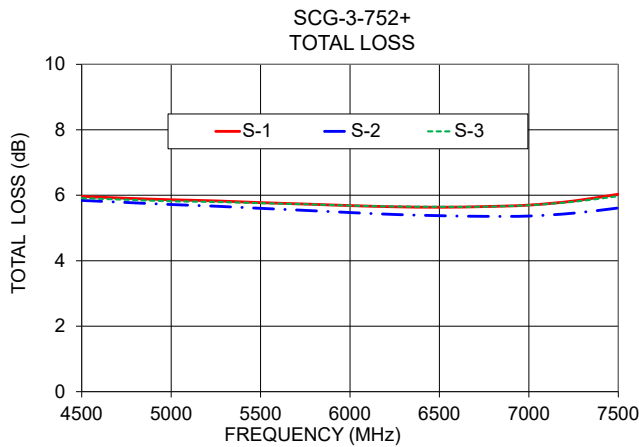

NOTES

- A. Performance and quality attributes and conditions not expressly stated in this specification document are intended to be excluded and do not form a part of this specification document.
- B. Electrical specifications and performance data contained in this specification document are based on Mini-Circuit's applicable established test performance criteria and measurement instructions.
- C. The parts covered by this specification document are subject to Mini-Circuits standard limited warranty and terms and conditions (collectively, "Standard Terms"); Purchasers of this part are entitled to the rights and benefits contained therein. For a full statement of the standard terms and the exclusive rights and remedies thereunder, please visit Mini-Circuits' website at www.minicircuits.com/terms/viewterm.html

