



COAXIAL HIGH POWER

Termination

TERM-50W-183S+

50Ω 50W DC to 18 GHz SMA Male

THE BIG DEAL

- Ultra-Wideband Operation, DC to 18 GHz
- Input Power Handling, 50W
- Excellent Return Loss, 26 dB Typ. up to 18 GHz



Generic photo used for illustration purposes only

Model No.	TERM-50W-183S+
Case Style	LL2798-3
Connectors	SMA Male

+RoHS Compliant

The +Suffix identifies RoHS Compliance.
See our website for methodologies and qualifications

APPLICATIONS

- Cellular Communications
- Satellite Communications
- Test set-up
- Defense and Radar

PRODUCT OVERVIEW

Mini-Circuits' TERM-50W-183S+ is an ultra-wideband 50Ω high power termination capable of absorbing signals up to 50W from DC to 18 GHz. It provides excellent return loss across its entire operating frequency range, effectively dissipating signal power with minimal reflections. This model has SMA male connectors, allowing connections with SMA female connectors. The unit features rugged construction for a long life of use and comes in passivated stainless steel connector with black anodized aluminum housing.

KEY FEATURES

Features	Advantages
Wideband, DC to 18 GHz	Extremely wide frequency range provides application flexibility and makes this model ideal for broadband and multi-band use.
Good Return Loss: • 26 dB typ. up to 18 GHz	Good return loss minimizes signal reflections across multiple-decade frequency range
Power Handling up to 50W	Meets a wide range of system power requirements.
Wide operating temperature range, -55 to +100 °C	Withstands tough operating conditions and is suitable for use near high power componentry where heat rise is common.





COAXIAL HIGH POWER

Termination

TERM-50W-183S+

Mini-Circuits

50Ω 50W DC to 18 GHz SMA Male

ELECTRICAL SPECIFICATIONS AT 25°C

Parameter	Condition (GHz)	Min.	Typ.	Max.	Units
Frequency Range	-	DC	-	18	GHz
Return Loss	DC - 6	19.1	35	-	dB
	6 - 12.4	16.5	28	-	
	12.4 - 18	14.7	26	-	
Input Power ¹	DC - 18	-	-	50	W

1. At 25°C, derate linearly to 20W at 100°C.

ABSOLUTE MAXIMUM RATINGS²

Parameter	Ratings
Operating Temperature	-55 °C to +100 °C
Storage Temperature	-55 °C to +100 °C

2. Permanent damage may occur if any of these limits are exceeded.



COAXIAL HIGH POWER

Termination

TERM-50W-183S+

Mini-Circuits

50Ω 50W DC to 18 GHz SMA Male

COAXIAL CONNECTIONS

Input	SMA Male
-------	----------

OUTLINE DRAWING

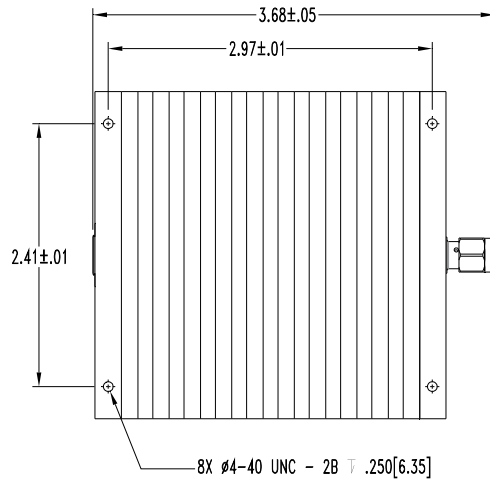
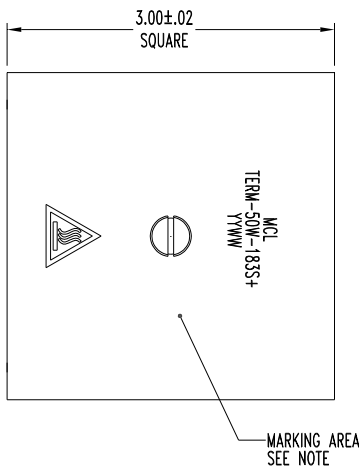
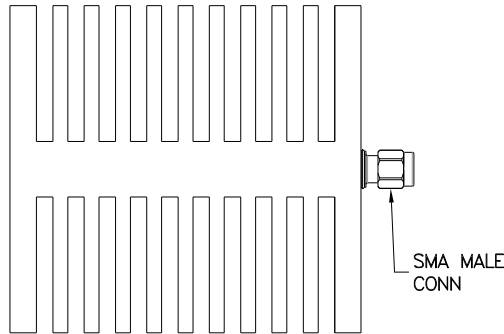

Weight: 862 grams (max.)

