



COAXIAL

Low Noise Amplifier

ZVA-44703LN+ ZVA-44703LNx+

50Ω 44 to 70 GHz NF 2.7 dB 1.85mm Female

THE BIG DEAL

- Exceptionally High Frequency
- Flat Gain Response, ±2.0 dB Typ.
- Low Noise Figure, 2.7 dB Typ.
- High P_{SAT}, +20 dBm Typ.
- Wide DC Operating Voltage, +10 To +15 V
- Over Voltage And Reverse Voltage Protected

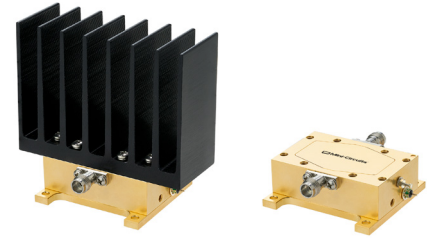

Generic photo used for illustration purposes only

APPLICATIONS

- 5G-FR2 Millimeter Wave Testing
- Aerospace & Defense
- Test and Measurement
- Q-band, V-band SATCOM
- Wireless Infrastructure
- IEEE 802.11.ad WiGig

FUNCTIONAL DIAGRAM

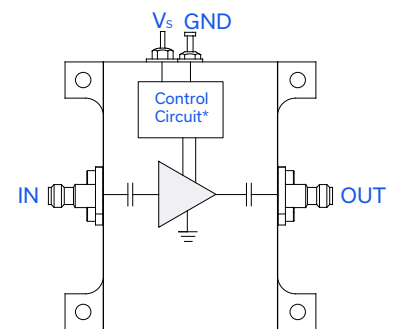

*Voltage Regulation, over-voltage, reverse voltage, and in-rush current protection circuit

PRODUCT OVERVIEW

Mini-Circuits' ZVA-44703LN+ is a coaxial wideband and low noise amplifier operating from 44 GHz to 70 GHz. The model operates over a positive supply range of +10 to +15 V, allowing users to choose their desired operating voltage. Internal DC-DC conversion circuitry maintains constant efficiency over the full input voltage range. The amplifier incorporates several DC-protection features such as over-voltage, reverse voltage, and in-rush current protection to protect from damage in case of unexpected spikes in voltage during operation. The high frequency operation combined with high gain and low noise figure makes this amplifier an ideal choice for SATCOM applications and 5G testing in millimeter wave bands.

KEY FEATURES

Features	Advantages
Wideband Amplifier, 44 to 70 GHz	A single broadband covers 5G millimeter wave bands as well as Q-Band and V-Band SATCOM receiver applications with critical noise figure requirements.
Low Noise, 2.7 dB Typ. High P _{SAT} , +20 dBm Typ.	Exceptionally low noise figure and medium output power at extremely high frequencies enables minimal system signal to noise degradation while providing high signal drive power for over-the-air and bench top test applications.
Wide DC Operating Voltage, +10 To +15 V	The device can operate from +10 to +15 V, maintaining constant DC power consumption with no effect on RF performance and facilitating ease of use in test setups with existing established voltage supplies.
DC Protection <ul style="list-style-type: none"> • Over-voltage • Reverse voltage • In-rush current 	The internal DC circuitry allows the amplifier to be protected from external mishandling or unexpected spikes in voltage that could lead to catastrophic failures in the field.





COAXIAL

Low Noise Amplifier

ZVA-44703LN+ ZVA-44703LNX+

50Ω 44 to 70 GHz NF 2.7 dB 1.85mm Female

ELECTRICAL SPECIFICATIONS AT +25 °C BASEPLATE

Parameter	Condition (GHz)	Min.	Typ.	Max.	Units
Frequency Range	-	44	-	70	GHz
Gain	44 - 70	41	45	-	dB
Noise Figure	44 - 70	-	2.7	-	dB
Output Power at 1 dB Compression (P1dB)	44 - 70	-	+18	-	dBm
Output Power at Saturation (P _{SAT}) ¹	44 - 70	-	+20	-	dBm
Output IP3	44-70	-	+28	-	dBm
Input Return Loss	44 - 70	-	13	-	dB
Output Return Loss	44 - 70	-	13	-	dB
DC Supply Voltage (V _S)	-	+10	-	+15	V
DC Current at V _S = +10V (Without/With Heatsink)	-	-	300	400 ²	mA

1. At P_{SAT}, P_{OUT} changes less than 0.1 dB for a 1 dB change in P_{IN}
2. Max DC Current at P_{SAT}. DC current increases as amplifier is driven into compression.



COAXIAL

Low Noise Amplifier

ZVA-44703LN+ ZVA-44703LNX+

50Ω 44 to 70 GHz NF 2.7 dB 1.85mm Female

TYPICAL PERFORMANCE GRAPHS

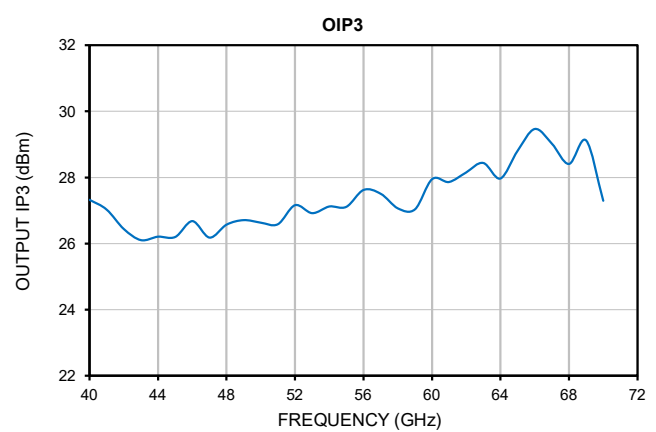
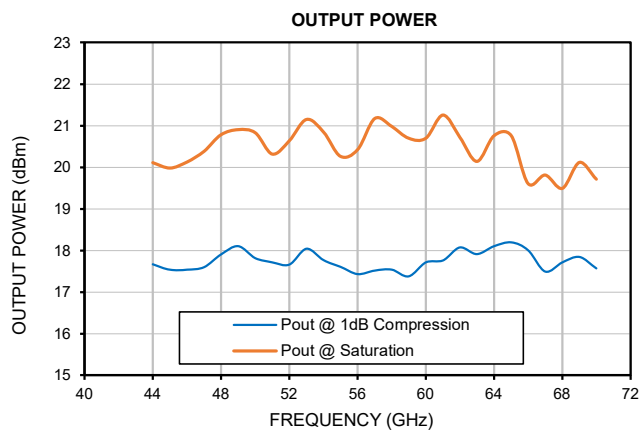
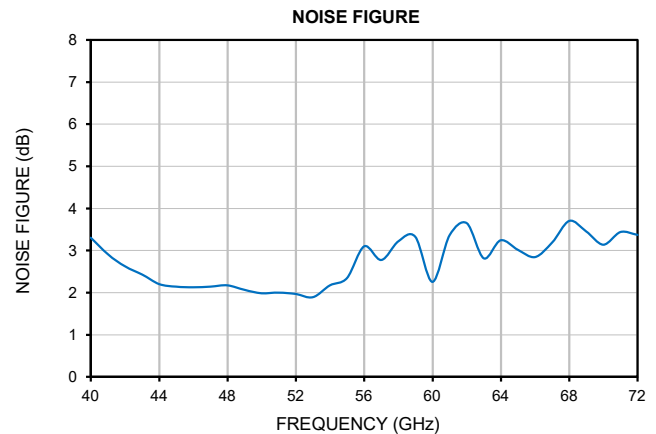
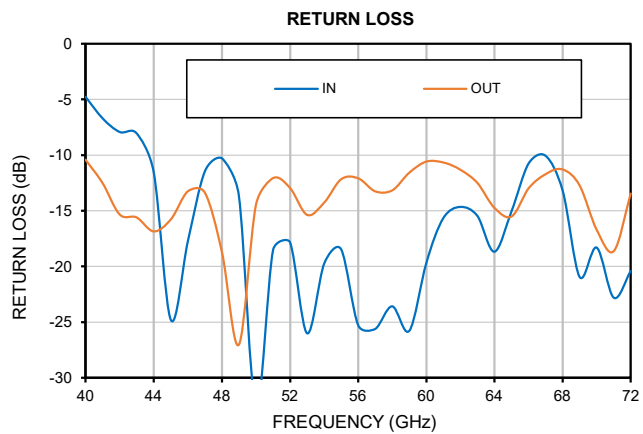
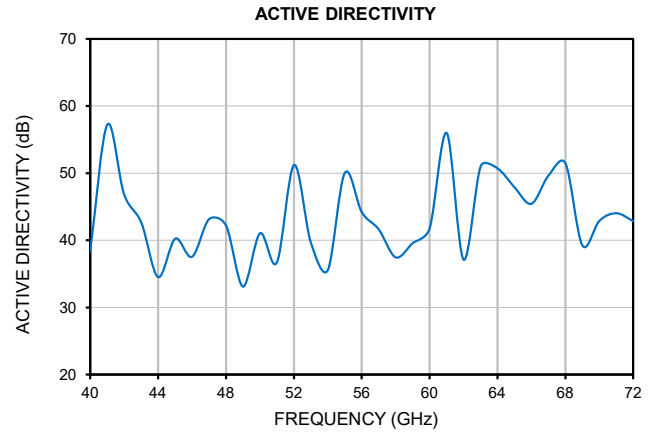
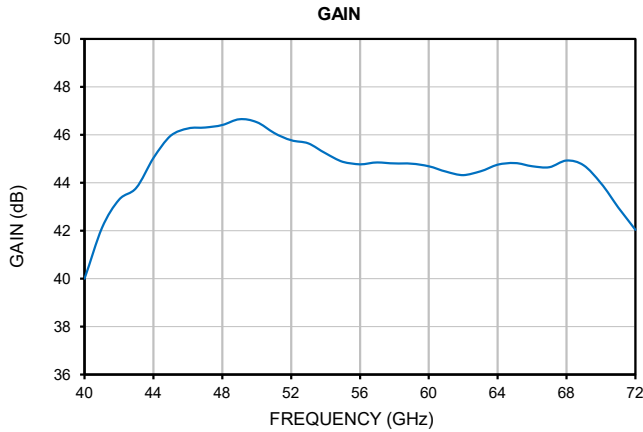



COAXIAL

Low Noise Amplifier

ZVA-44703LN+ ZVA-44703LNX+

50Ω 44 to 70 GHz NF 2.7 dB 1.85mm Female

ABSOLUTE MAXIMUM RATINGS³

Parameter	Ratings		
Operating Temperature	ZVA-44703LN+	-40 °C to +50 °C	Ambient
	ZVA-44703LNX+	-40 °C to +60 °C	Baseplate
Storage Temperature	-40 °C to +85 °C		
Total Power Dissipation	4.5 W		
RF Input Power ⁴ (CW)	+15 dBm		
DC Operating Voltage (V _S)	+16 V		

3. Continuous operation is not recommended at these extremes. Permanent damage may occur if any of these limits are exceeded.

4. Specified under matched load to 50 ohms.

DETERMINING MAXIMUM THERMAL RESISTANCE OF USERS' EXTERNAL HEAT SINK

$\text{MAXIMUM THERMAL RESISTANCE} = \frac{\text{MAXIMUM OPERATING CASE TEMP} - \text{MAXIMUM USER AMBIENT TEMP}}{\text{POWER DISSIPATION}}$	
Example:	<p>MAXIMUM OPERATING CASE TEMP = +50 °C (CHECK MAXIMUM RATINGS TABLE FOR THIS VALUE)</p> <p>MAXIMUM USER AMBIENT TEMP = +30 °C (USER DEFINED)</p> <p>POWER DISSIPATION = 10 WATTS (CHECK MAXIMUM RATINGS TABLE FOR THIS VALUE)</p> <p>THEN MAXIMUM ALLOWABLE THERMAL RESISTANCE = 2 °C/W</p>





COAXIAL

Low Noise Amplifier

ZVA-44703LN+ ZVA-44703LNx+

Mini-Circuits

50Ω 44 to 70 GHz NF 2.7 dB 1.85mm Female

CASE STYLE DRAWING WITH HEATSINK (ZVA-44703LN+)

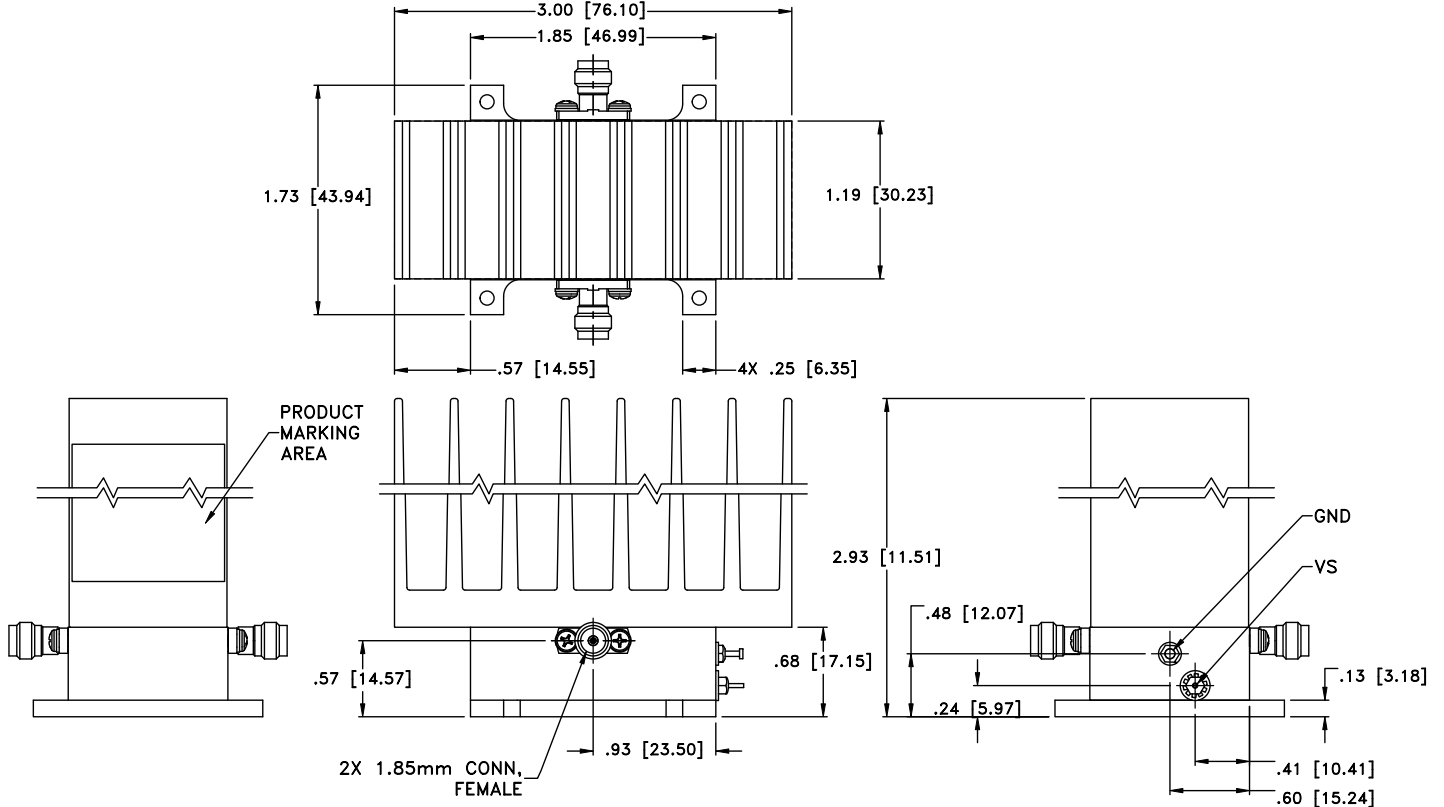

CASE STYLE DRAWING WITHOUT HEATSINK (ZVA-44703LNx+)

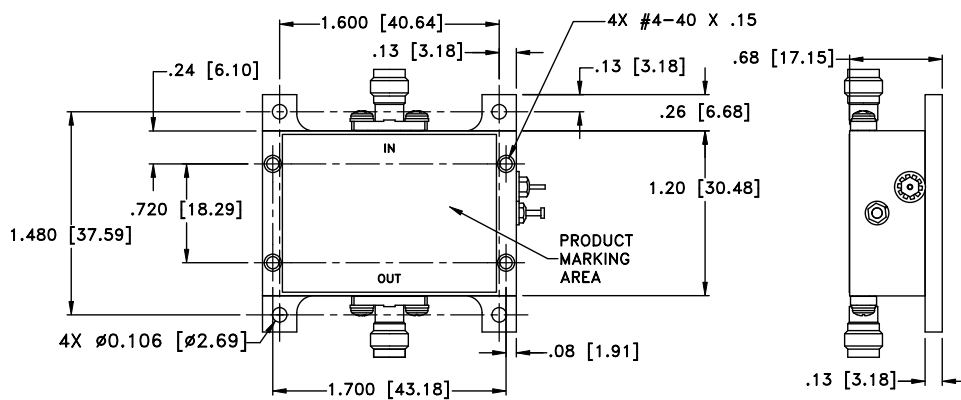

Weight: 160 grams; without heatsink: 60 grams

Dimensions are in inches [mm]. Tolerances: 2 Pl. ±.03; 3 Pl. ±.015 Inches





COAXIAL

Low Noise Amplifier

ZVA-44703LN+ ZVA-44703LNX+

50Ω 44 to 70 GHz NF 2.7 dB 1.85mm Female

ADDITIONAL INFORMATION IS AVAILABLE ON OUR DASHBOARD.

Performance Data	Data Table
	Swept Graphs
	S-Parameter (S2P Files) Data Set (.zip file)
RoHs Status	Compliant
Environmental Ratings	ENV130
Export Information	EAR99

ORDERING INFORMATION

Model No. Links	ZVA-44703LN+	ZVA-44703LNX+
Option	With heatsink	Without heatsink
Product Marking	ZVA-44703LN+	ZVA-44703LNX+
Case Style	WC3071-7	
Connector	1.85mm (Female)	

NOTES

- A. Performance and quality attributes and conditions not expressly stated in this specification document are intended to be excluded and do not form a part of this specification document.
- B. Electrical specifications and performance data contained in this specification document are based on Mini-Circuit's applicable established test performance criteria and measurement instructions.
- C. The parts covered by this specification document are subject to Mini-Circuits standard limited warranty and terms and conditions (collectively, "Standard Terms"); Purchasers of this part are entitled to the rights and benefits contained therein. For a full statement of the standard terms and the exclusive rights and remedies thereunder, please visit Mini-Circuits' website at www.minicircuits.com/terms/viewterm.html

