

Evaluation Board and Circuit

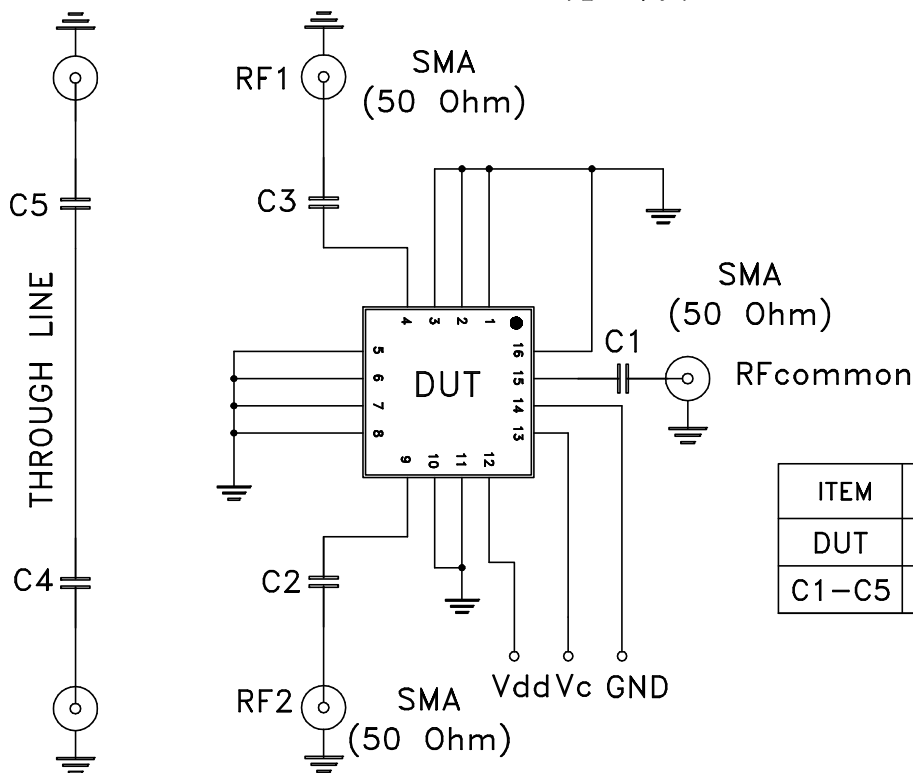
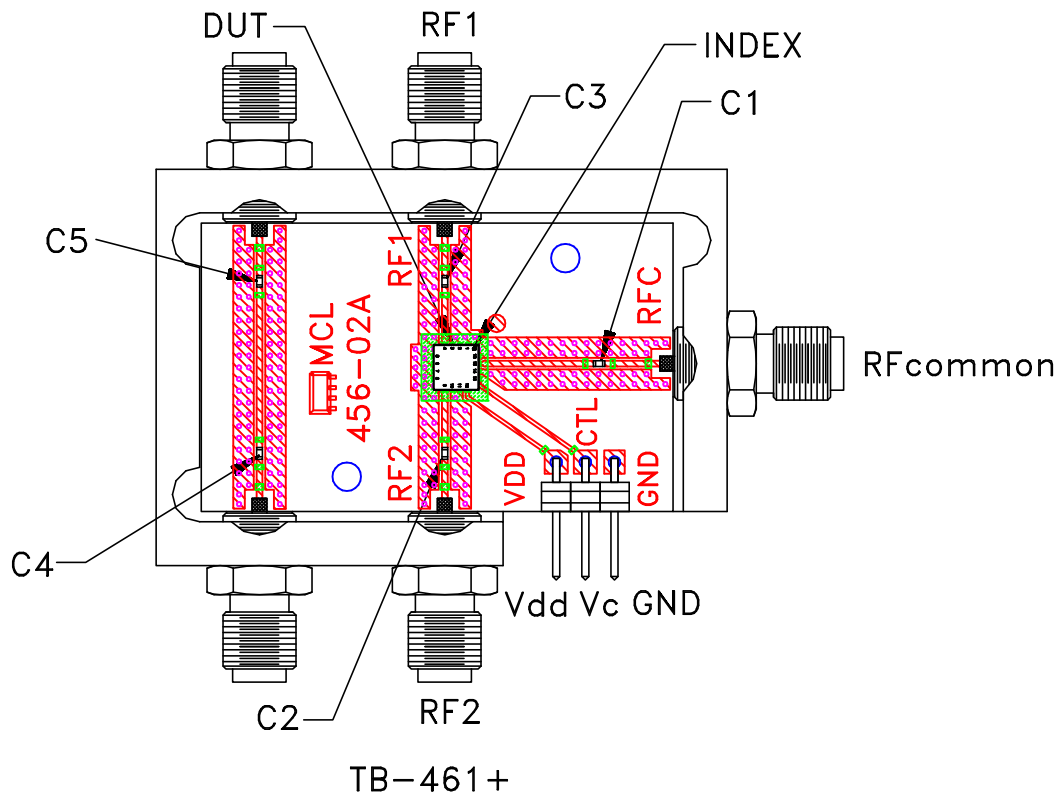

ITEM	DESCRIPTION	SIZE
DUT	CSWA2-63DR+	4X4 MM
C1-C5	CAP, 47 pF	0402

Schematic Diagram

Notes:

1. SMA Female connectors.
2. PCB Material: Rogers R04350 or equivalent,
Dielectric Constant=3.5, Thickness=.010 inch.

 **Mini-Circuits®**