

Evaluation Board and Circuit

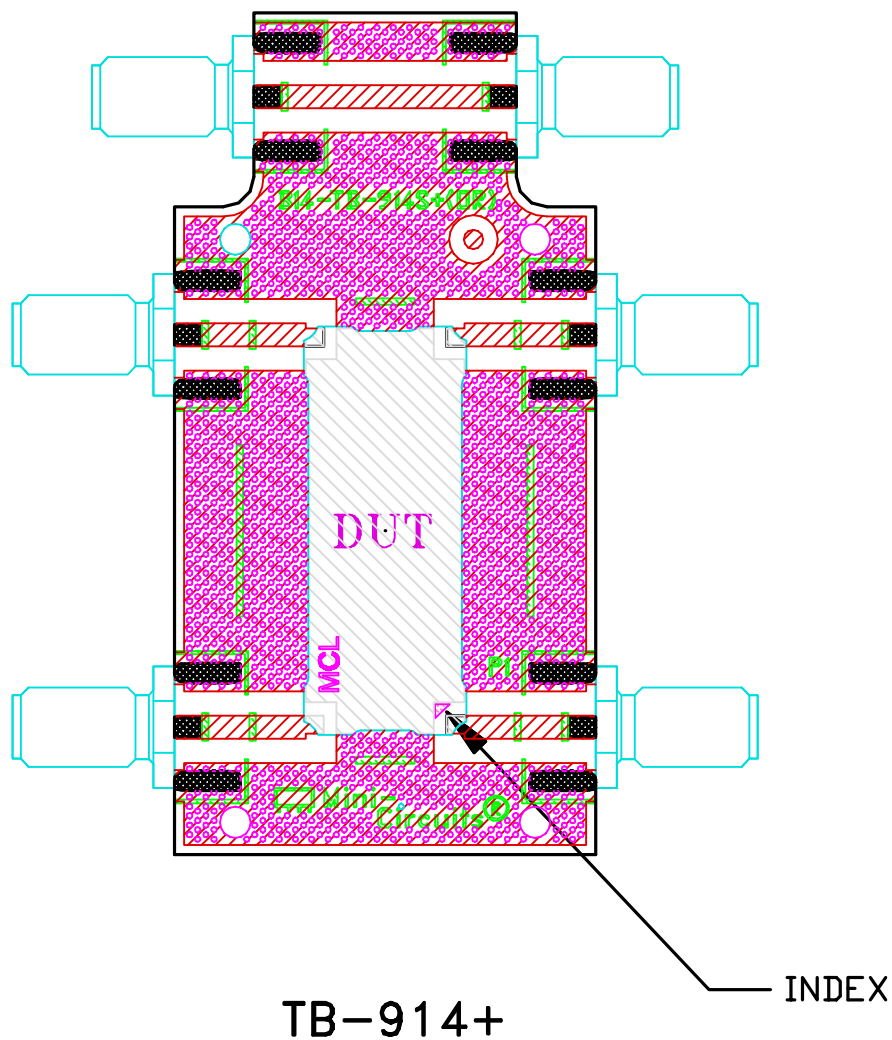

NOTES:

1. SMA FEMALE CONNECTORS.
2. PCB MATERIAL: ROGERS R04003C OR EQUIVALENT, DIELECTRIC CONSTANT=3.5, DIELECTRIC THICKNESS=.032 INCH.

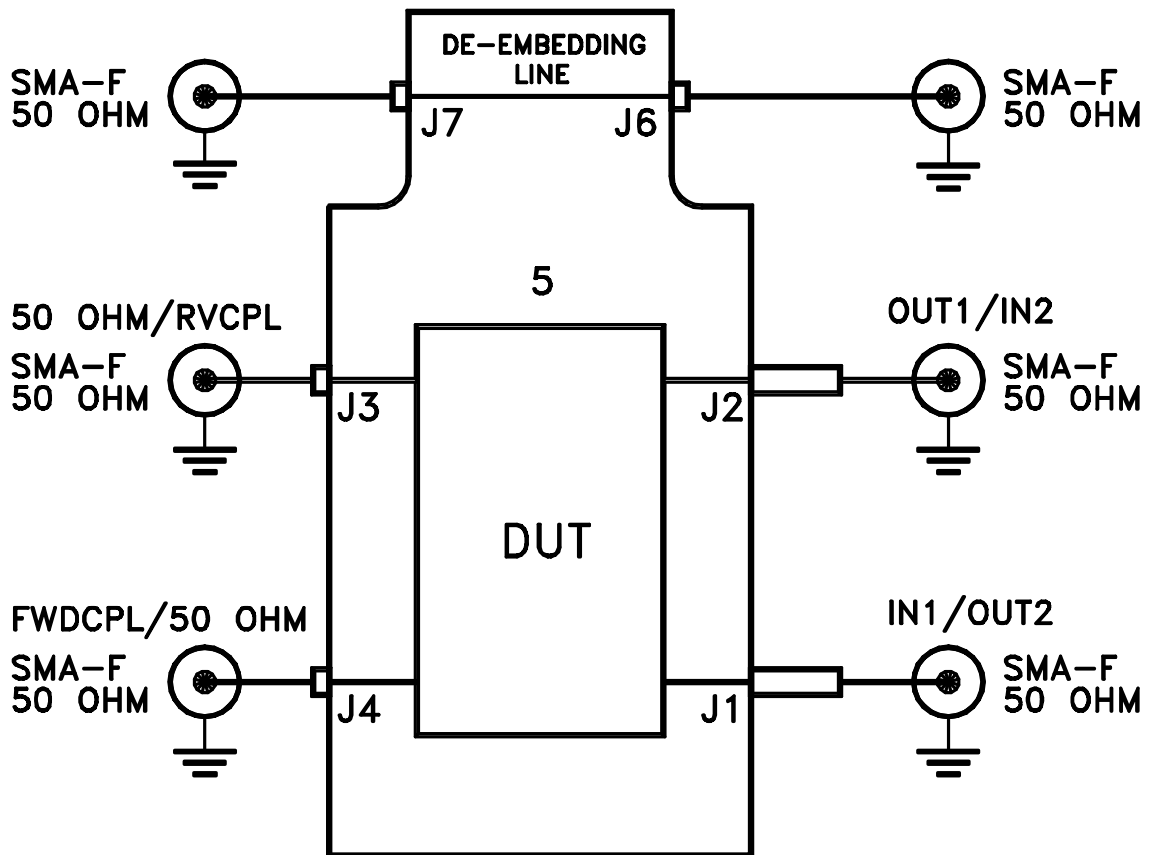

TB-914+
Schematic Diagram