

# Evaluation Board and Circuit

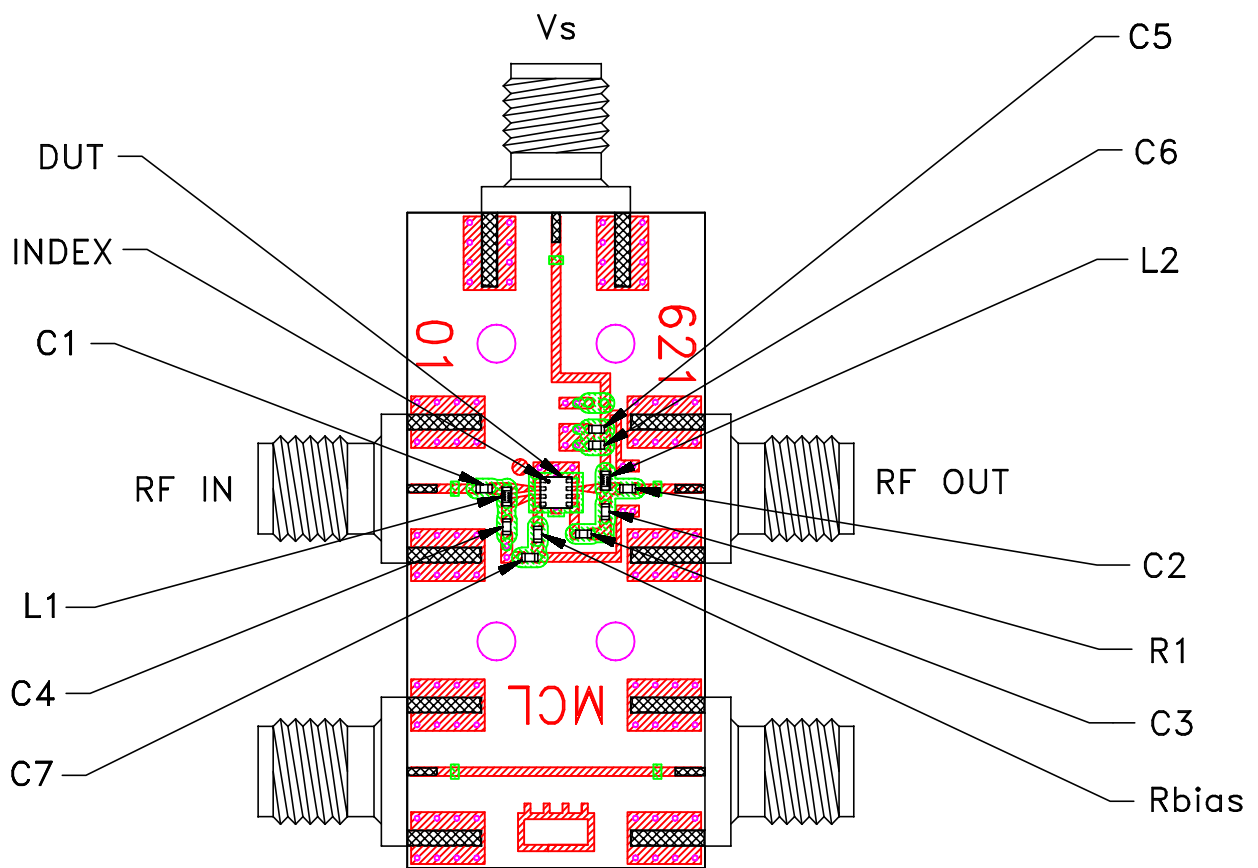

TB-PMA2252LNAC+

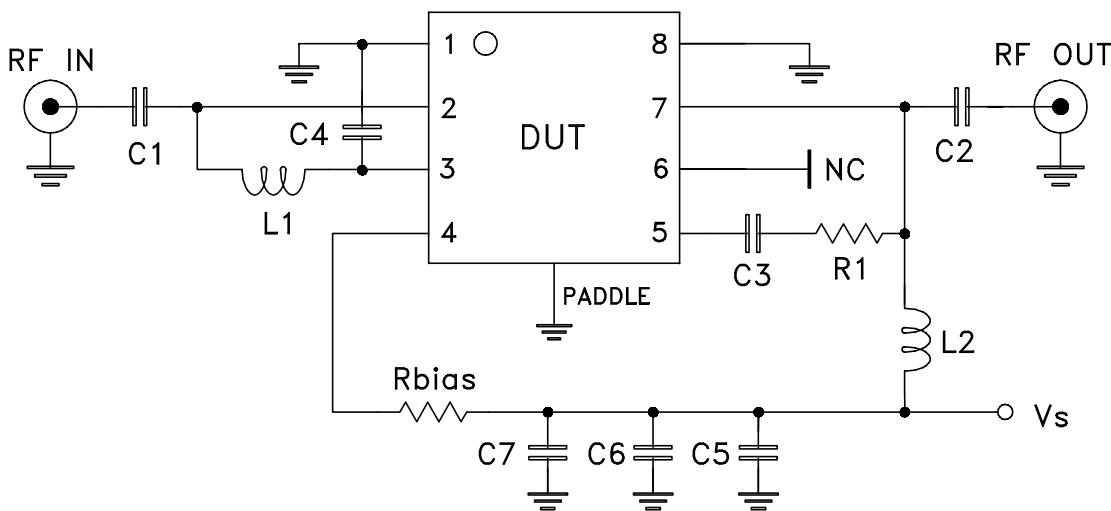

Schematic Diagram

ITEM	DESCRIPTION
C1	CAP, 27pF
C2	CAP, 2.7pF
C3	CAP, 1.2pF
C4	CAP, 220pF
C5	CAP, 7pF
C6, C7	CAP, 0.1uF
R1	RES, 825 Ohm
Rbias	RES, 619 Ohm
L1	IND, 6.8nH
L2	IND, 2.2nH
DUT	PMA2-252LNA+

## NOTES:

1. SMA Female connectors.
2. PCB material: Rogers R04350 or equivalent, dielectric constant=3.5, dielectric thickness=.010 inch.

 **Mini-Circuits®**