



## MMIC SURFACE MOUNT WIDEBAND

# Double Balanced Mixer

## MDB-54H+

Mini-Circuits

Level 15 (LO Power 15dBm) 20-50 GHz

### THE BIG DEAL

- Super wideband RF & LO, 20-50 GHz
- Super wideband IF, DC-20 GHz
- High L-R Isolation, 45 dB typ.
- Excellent Input IP3, 20 dBm Typ.
- Usable as Up & Down Converter



CASE STYLE: DQ1225

Generic photo used for illustration purposes only

#### +RoHS Compliant

The +Suffix identifies RoHS Compliance. See our web site for RoHS Compliance methodologies and qualifications

### APPLICATIONS

- Satellite up and down converters
- Defense radar & communication
- WiGig
- 5G
- ISM

### PRODUCT OVERVIEW

MDB-54H+ is super-wideband double balanced mixer fabricated using InGaP HBT technology. The MDB-54H+ mixer functions as an up converter or down converter for LO and RF frequencies from 20 to 50 GHz and covers IF bandwidths from DC-20 GHz. The Mixer operates with 15 dBm LO power level while providing 11 dB conversion loss, 45 dB LO/RF isolation and 20 dBm input IP3. The mixer is ideal for use in wideband millimeter wave systems for communications, defense and test and measurement applications.

### KEY FEATURES

Feature	Advantages
Double Balanced	Results in excellent LO-RF (35-55 dB typical) & LO-IF (23-52 dB typical) Isolations mini-mizing need for external filtering
Wide Bandwidth, 20 to 50 GHz	Useful in wideband systems or in in several narrowband systems. Reducing inventory
Wide IF Bandwidth DC-20 GHz	Usable in first and second down converter applications. IF as low as DC enables use in phase detector applications.
3 mm x 3 mm, 12 lead MCLP Package	Low Inductance, repeatable transitions, excellent thermal contact to PCB

REV. A  
ECO-009182  
MDB-54H+  
MCL NY  
210810



ELECTRICAL SPECIFICATIONS<sup>1</sup> AT 25°C, UNLESS NOTED

Parameter	Condition (GHz)	Min.	Typ.	Max.	Units
RF Frequency Range	-	20	-	50	GHz
LO Frequency Range	-	20	-	50	GHz
IF Frequency Range	-	DC	-	20	GHz
LO Power	-	14	+15	16	dBm
Conversion Loss (at IF=2 GHz)	20	-	9.8	12	dB
	30	-	10.2	12	
	40	-	12.6	-	
	50	-	13	-	
LO-RF Isolation	20	25	36	-	dB
	30	25	42	-	
	40	-	40	-	
	50	-	45	-	
LO-IF Isolation	20	20	34	-	dB
	30	20	44	-	
	40	-	31	-	
	50	-	30	-	
RF-IF Isolation	20	20	30	-	dB
	30	20	34	-	
	40	-	24	-	
	50	-	26	-	
Pin at 1dB Compression	20-50	-	10	-	dBm
Input IP3	20-50	-	20	-	dBm

1. Measured on Mini-Circuits Characterization test board TB-MDB-54H+. See Characterization Test Circuit Figure 1A-1F

MAXIMUM RATINGS<sup>2</sup>

Parameter	Ratings
Operating Temperature	-40°C to 85°C
Storage Temperature	-65°C to 150°C
RF Power	21 dBm
LO Power	21 dBm
IF Current	30 mA

2. Permanent damage may occur if any of these limits are exceeded. Electrical maximum ratings are not intended for continuous normal operation.



### SIMPLIFIED SCHEMATIC AND BONDING PAD DESCRIPTION

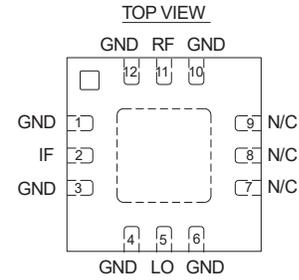
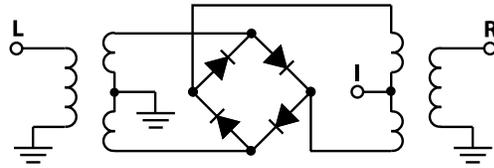

### PAD CONNECTIONS

Function	Pad Number	Description
RF	11	RF port
LO	5	LO port
IF	2	IF port
GND	1,3,4,6,10,12 & Paddle	Connects to Ground Pads at Die Level. Grounded on PCB.
NC	7,8 & 9	Not Connected, Grounded on PCB

### PRODUCT MARKING

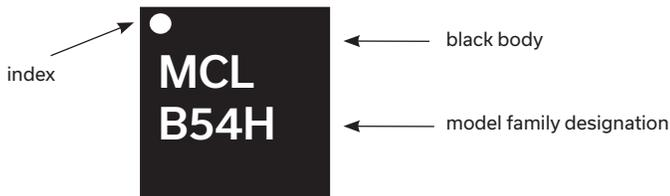



## CHARACTERIZATION TEST CIRCUITS

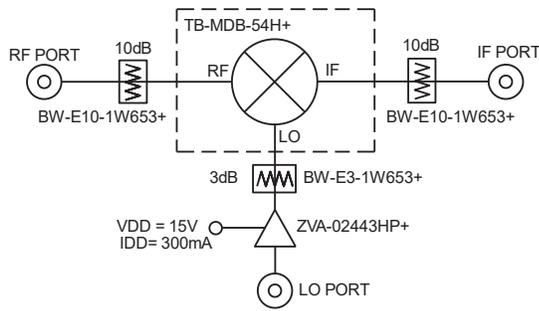

Figure 1A. Block Diagram of Test Circuit used for characterization of Conversion Loss, Isolation (L-R,L-I, R-I) & VSWR from 20 to 35 GHz.

Test Condition:

RF = -10dBm, LO = 15dBm, IF = 30MHz, 2GHz & 3GHz

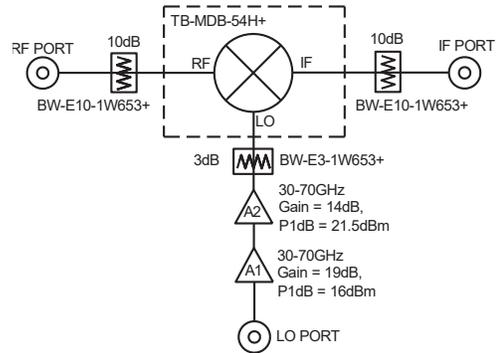

Figure 1B. Block Diagram of Test Circuit used for characterization of Conversion Loss, Isolation (L-R,L-I, R-I) & VSWR from 35 to 50 GHz.

Test Condition:

RF = -10dBm, LO = 15dBm, IF = 30MHz, 2GHz & 3GHz

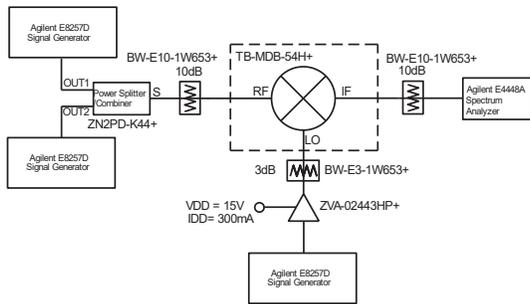

Figure 1C. Block Diagram of Test Circuit used for characterization of Input IP3 from 20 to 35GHz

Test Condition: RF = -10dBm/Tone, LO = 15dBm, IF = 2GHz

Input IP3 (IIP3): Two tones, spaced 1MHz apart

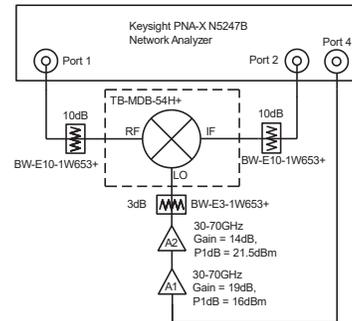

Figure 1D. Block Diagram of Test Circuit used for characterization of Input IP3 from 35 to 50 GHz

Test Condition:

RF = -10dBm/Tone, LO = 15dBm, IF = 2GHz

Input IP3 (IIP3): Two tones, spaced 1MHz apart

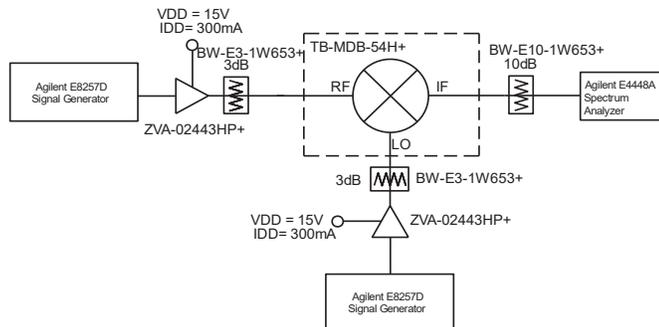

Figure 1E. Block Diagram of Test Circuit used for characterization of Compression from 20 to 35 GHz

Test Condition:

RF = 10dBm & -10dBm, LO = 15dBm, IF = 2GHz

Compression = CL(RF = 10dBm) - CL(RF = -10dBm)

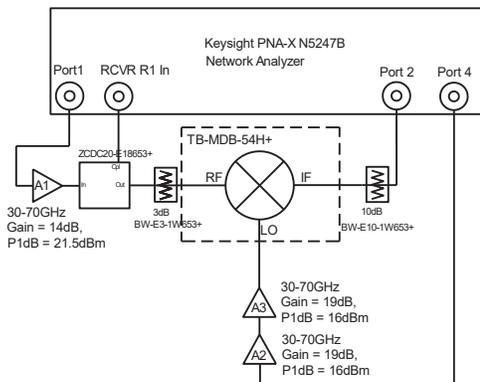

Figure 1F. Block Diagram of Test Circuit used for characterization of Compression from 35 to 50GHz

Test Condition:

RF = 10dBm & -10dBm, LO = 15dBm, IF = 2GHz

Compression = CL(RF = 10dBm) - CL(RF = -10dBm)



ADDITIONAL DETAILED TECHNICAL INFORMATION IS AVAILABLE ON OUR DASH BOARD. TO ACCESS [CLICK HERE](#)

Performance Data	Data Table Swept Graphs S-Parameter (S1P Files) Data Set (.zip file)
Case Style	DQ1225 Plastic package, exposed paddle, lead finish: matte-tin
Tape & Reel Standard quantities available on reel	F66 7" reels with 20, 50, 100, 200, 500, 1K and 2K devices
Suggested Layout for PCB Design	PL-705
Evaluation Board	TB-MDB-54H+
Environmental Ratings	ENV08T1

### ESD RATING

Human Body Model (HBM): Class 1A (250 to <500V) in accordance with ANSI/ESD STM 5.1 - 2001

### MSL RATING

Moisture Sensitivity: MSL1 in accordance with IPC/JEDEC J-STD-020D

### MSL TEST FLOW CHART

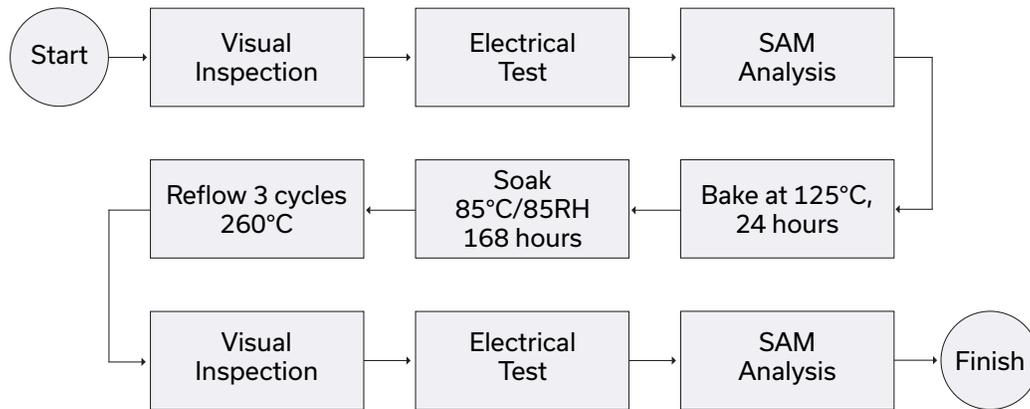

- NOTES**
- A. Performance and quality attributes and conditions not expressly stated in this specification document are intended to be excluded and do not form a part of this specification document.
  - B. Electrical specifications and performance data contained in this specification document are based on Mini-Circuit's applicable established test performance criteria and measurement instructions.
  - C. The parts covered by this specification document are subject to Mini-Circuits standard limited warranty and terms and conditions (collectively, "Standard Terms"); Purchasers of this part are entitled to the rights and benefits contained therein. For a full statement of the standard. Terms and the exclusive rights and remedies thereunder, please visit Mini-Circuits' website at [www.minicircuits.com/MCLStore/terms.jsp](http://www.minicircuits.com/MCLStore/terms.jsp)