

MAV Kit Test Board: Instructions for Use

(AN-60-025)

Introduction

MAV Models are series of wide band amplifiers. They have different device voltages and currents (refer to catalog spec). The test board has been constructed in such a way as to make it useful for evaluating all the devices by suitable selection of bias resistor. This is done by soldering jumper wires across the specified dashed-line positions 1 to 5 shown in Fig.1.

The Test Board has the following components:

Component	Value	Function
C1 & C2	39000 pF	DC blocking
L1	MCL Model # ADCH-80A	RF choke
R1	95.5Ω	Sets bias current
R2	147Ω	Sets bias current
R3	206Ω	Sets bias current
R4	375Ω	Sets bias current
R5	288	Sets bias current
R6	4.75Ω	Sets bias current
D1	Zener, 10V	Protects against excessive supply voltage
C3	0.1μF	Bypass capacitor; Bypass noise of supply voltage

Model No.	Short at Position
MAV-1A	4
MAV-2A	3
MAV-3A	2
MAV 11A	1 & 5
MAV-1SM	5
MAV-4SM	1
MAV-11SM	1 & 5
MAV-11BSM	1 & 5

Fig 1. Schematic of the Test Board MAV - TB

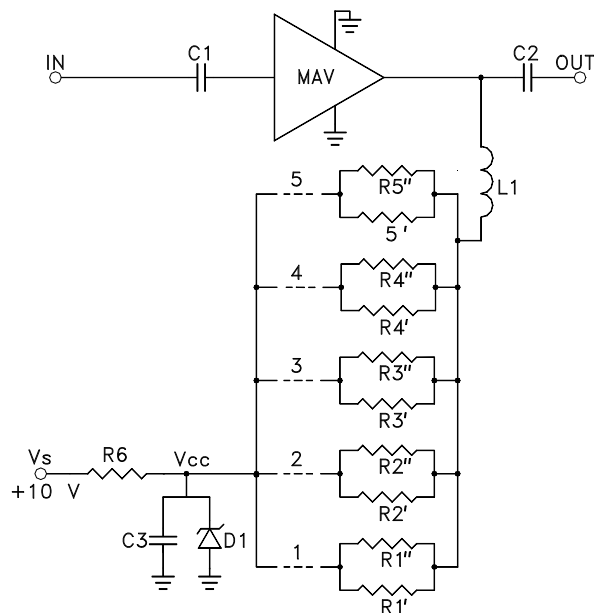

Procedure

Follow these steps to use the Test Board. Figure 2 shows the layout.

1. Solder selected MAV unit onto Test Board.
2. Make DC connection by soldering jumper wires in accordance with the table, depending on the selected MAV model. All other positions should be open.
3. Calibrate test setup.
4. First, connect the RF output port of the test board to Network/Spectrum analyzer. Then, apply +10 V DC (10.2V max). Finally, apply RF input to the test board from Network Analyzer.
5. Test Board has Insertion Loss due to the length of its lines, DC blocking capacitors and RF choke as shown below. Add this loss to the measured gain to get actual gain.

Frequency (GHz)	Insertion Loss (dB)
0.1	0.43
0.5	0.5
1	0.59
2	0.79
4	0.92
6	1.78

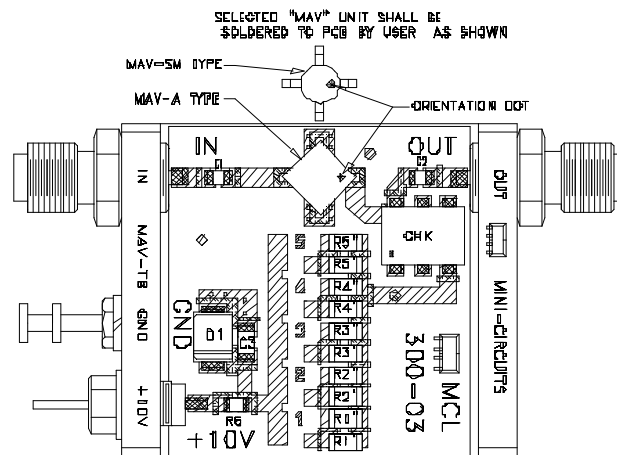

Fig 2. Layout of the Test Board MAV-TB

IMPORTANT NOTICE

© 2015 Mini-Circuits

This document is provided as an accommodation to Mini-Circuits customers in connection with Mini-Circuits parts only. In that regard, this document is for informational and guideline purposes only. Mini-Circuits assumes no responsibility for errors or omissions in this document or for any information contained herein.

Mini-Circuits may change this document or the Mini-Circuits parts referenced herein (collectively, the "Materials") from time to time, without notice. Mini-Circuits makes no commitment to update or correct any of the Materials, and Mini-Circuits shall have no responsibility whatsoever on account of any updates or corrections to the Materials or Mini-Circuits' failure to do so.

Mini-Circuits customers are solely responsible for the products, systems, and applications in which Mini-Circuits parts are incorporated or used. In that regard, customers are responsible for consulting with their own engineers and other appropriate professionals who are familiar with the specific products and systems into which Mini-Circuits' parts are to be incorporated or used so that the proper selection, installation/integration, use and safeguards are made. Accordingly, Mini-Circuits assumes no liability therefor.

In addition, your use of this document and the information contained herein is subject to Mini-Circuits' standard terms of use, which are available at Mini-Circuits' website at www.minicircuits.com/homepage/terms_of_use.html.

Mini-Circuits and the Mini-Circuits logo are registered trademarks of Scientific Components Corporation d/b/a Mini-Circuits. All other third-party trademarks are the property of their respective owners. A reference to any third-party trademark does not constitute or imply any endorsement, affiliation, sponsorship, or recommendation: (i) by Mini-Circuits of such third-party's products, services, processes, or other information; or (ii) by any such third-party of Mini-Circuits or its products, services, processes, or other information.