

Outline Dimensions

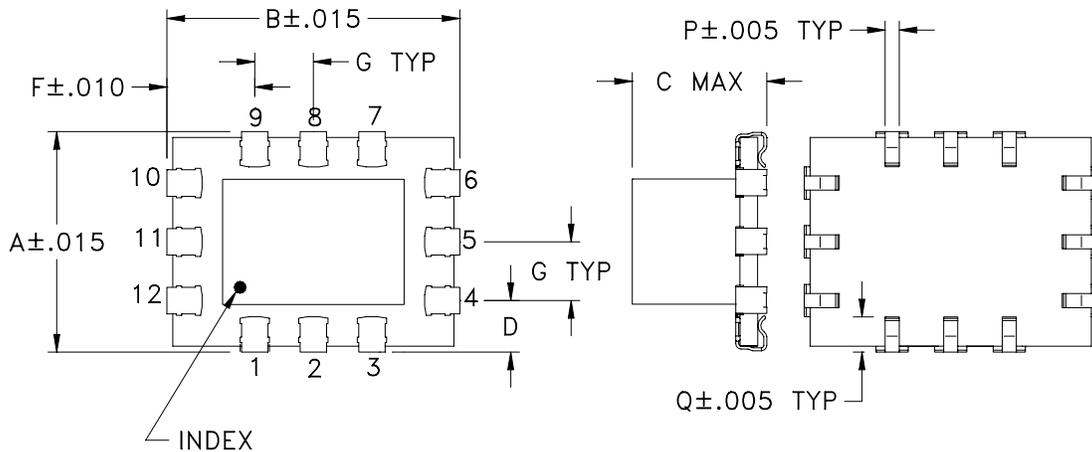

PCB Land Pattern

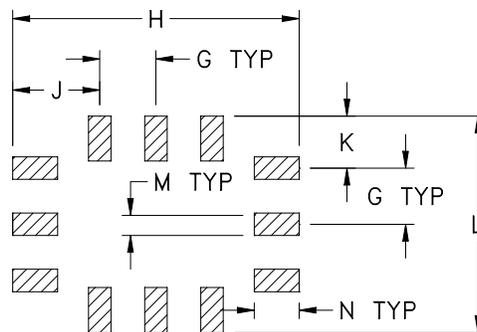

Suggested Layout,
Tolerance to be within $\pm.002$

CASE #	A	B	C	D	E	F	G	H	J	K	L	M
CG581	.375 (9.53)	.500 (12.70)	.230 (5.84)	.087 (2.21)	-- --	.15 (3.81)	.100 (2.54)	.510 (12.95)	.155 (3.94)	.093 (2.36)	.385 (9.78)	.040 (1.02)

CASE #	N	P	Q	WT. GRAM
CG581	.080 (2.03)	.024 (0.61)	.060 (1.52)	0.6

Dimensions are in inches (mm). Tolerances: 2 Pl. $\pm.01$; Pl. $\pm.005$

Notes:

- Case material: Ceramic.
- Termination finish:
For RoHS Case Styles: Tin plate over Nickel plate. All models, (+) suffix.
For RoHS-5 Case Styles: Tin-Lead plate. All models, no (+) suffix.



Distribution Centers NORTH AMERICA 800-654-7949 • 417-335-5935 • Fax 417-335-5945 • EUROPE 44-1252-832600 • Fax 44-1252-837010

Mini-Circuits ISO 9001 & ISO 14001 Certified

INTERNET <http://www.minicircuits.com>

P.O. Box 350166, Brooklyn, New York 11235-0003 (718) 934-4500 Fax (718) 332-4661