

# Case Style

# SM34

SM34

## Outline Dimensions

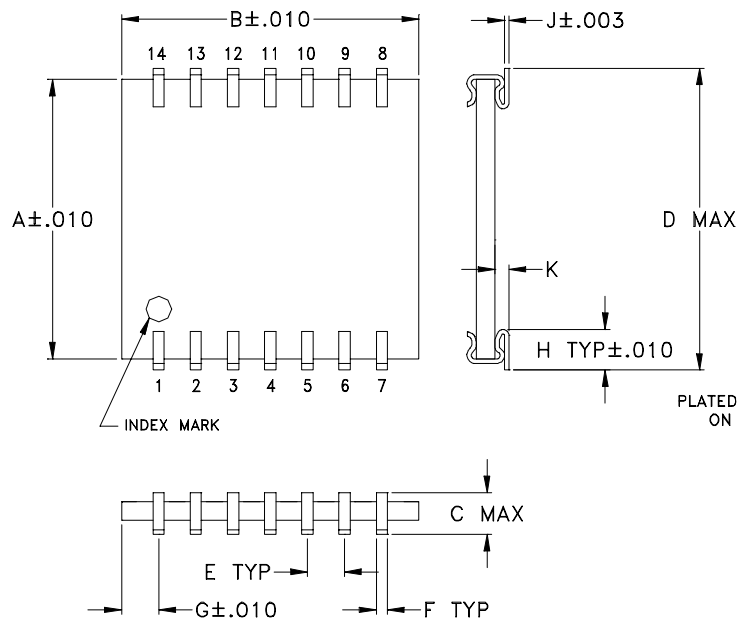

## PCB Land Pattern

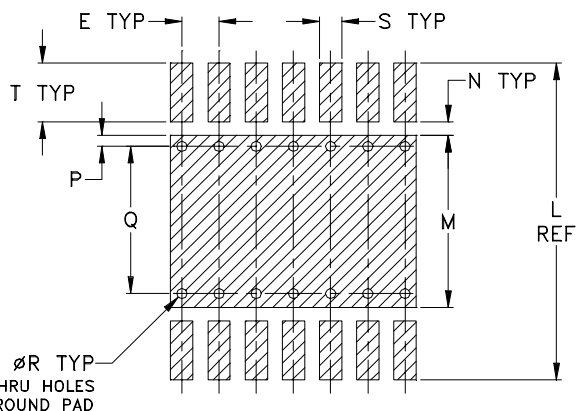

Suggested Layout,  
Tolerance to be within  $\pm 0.002$

ADJACENT GROUND PINS SHALL BE CONNECTED  
TO EACH OTHER AND TO GROUND PAD

CASE #	A	B	C	D	E	F	G	H	J	K	L	M	N
SM34	.380 (9.65)	.400 (10.16)	.070 (1.78)	.420 (10.67)	.050 (1.27)	.015 (0.38)	.050 (1.27)	.060 (1.52)	.006 (0.15)	.020 (0.51)	.430 (10.92)	.234 (5.94)	.018 (0.46)

CASE #	P	Q	R	S	T	WT. GRAM
SM34	.015 (0.38)	.200 (5.08)	.014 (0.36)	.030 (0.76)	.080 (2.03)	.3

Dimensions are in inches (mm). Tolerances:  $\pm .005$

### Notes:

- Case material: Ceramic.
- Termination finish:  
For RoHS Case Styles: Tin plate over Nickel plate.  
For RoHS-5 Case Styles: Tin-Lead plate.



Distribution Centers NORTH AMERICA 800-654-7949 • 417-335-5935 • Fax 417-335-5945 • EUROPE 44-1252-832600 • Fax 44-1252-837010

Mini-Circuits ISO 9001 & ISO 14001 Certified

INTERNET <http://www.minicircuits.com>

P.O. Box 350166, Brooklyn, New York 11235-0003 (718) 934-4500 Fax (718) 332-4661