

New Product Announcement!

High Power Amplifier

ZHL-16W-43+

Release Date: April 2009



ZHL-16W-43+
Price: \$1595 (QTY 1-9)

ZHL-16W-43X+
Price: \$1545 (QTY 1-9)

The Big Deal:

- Broadband - High Power, 16 Watt
- Rugged
- Internal Protection from Load and Temperature

Product Overview:

Mini-Circuits ZHL-16W-43+ offers high power (16W) with rugged reliability over a broad frequency range from 1800 to 4000 MHz. This model includes temperature sensing circuits for automatic shutdown and output load protection to operate into a short or an open load making it ideal for use in laboratory or field applications.

Summary Performance at 2 GHz		
P_{OUT} @ 3dB (P_{SAT})	16	W, typ.
Gain	45	dB, typ.
IP3	+47	dBm, typ.
P_{OUT} (at 1dB)	+41	dBm, typ.
DC Current (at 28V)	4.3	A, max.
Operating Frequency: 1800 to 4000 MHz		

Key Features

Feature	Advantages
Combination of Power and Bandwidth	Offering a unique combination of output power over a broad frequency range, the ZHL-16W-43+ is ideal for laboratory and other test applications which require a high degree of flexibility to delivery power over a wide array of applications including <ul style="list-style-type: none"> • PCS, UMTS, LTE and wireless • WiMAX • Radar • Microwave radio and ISM
Excellent Input and Output VSWR	With 1.3:1 output VSWR, the ZHL-16W-43+ is designed for use in driving circuits with a variety of impedances and still provide consistent, reliable output power.
Over Temp Shutdown	The ZHL-16W-43+ includes internal temperature monitoring circuits to automatically shut down the amplifier in the event of over temperature operation. Set for approximately +85°C shutdown (with auto recovery at 70°C), this feature ensures that users whom have difficulty in controlling their thermal environment or need to operate in a remote mode and cannot monitor the amplifier real time, can function with the security that a thermal run-away condition will be avoided through this self management feature. Furthermore, the ZHL-16W-43+ provides a TTL output to indicate thermal shutdown for remote automated systems.
Output Load Protection	A high root cause for damage to power amplifiers is the operation into highly reflective loads. The ZHL-16W-43+ power amplifier includes circuits to enable the amplifier to operate without damage in the presence of an open or short over all phases.



P.O. Box 350166, Brooklyn, New York 11235-0003 (718) 934-4500 Fax (718) 332-4661 The Design Engineers Search Engine Provides ACTUAL Data Instantly at minicircuits.com

IF/RF MICROWAVE COMPONENTS

For detailed performance specs & shopping online see web site

Notes: 1. Performance and quality attributes and conditions not expressly stated in this specification sheet are intended to be excluded and do not form a part of this specification sheet. 2. Electrical specifications and performance data contained herein are based on Mini-Circuit's applicable established test performance criteria and measurement instructions. 3. The parts covered by this specification sheet are subject to Mini-Circuits standard limited warranty and terms and conditions (collectively, "Standard Terms"); Purchasers of this part are entitled to the rights and benefits contained therein. For a full statement of the Standard Terms and the exclusive rights and remedies thereunder, please visit Mini-Circuits' website at www.minicircuits.com/MCLStore/terms.jsp. ZHL-16W-43+ Prod Rise 090625 Page 1 of 2

Typical Application Block Diagram: Driver Amp in Test Lab

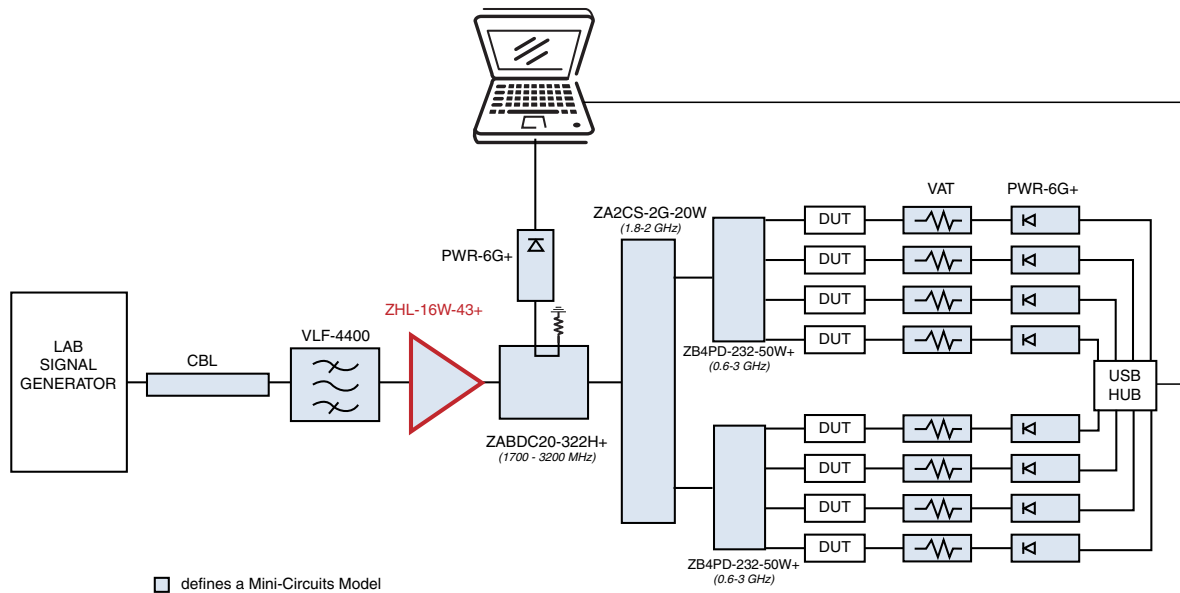

The ZHL-16W-43+ is ideal in lab applications. With 16W output power, this amplifier can be used to drive test signals into multiple DUT's simultaneously combined with a Mini-Circuits power splitter and multiple power sensors, this becomes a powerful tool for reliability testing and quality screening.

Typical Application Block Diagram: EMI Testing

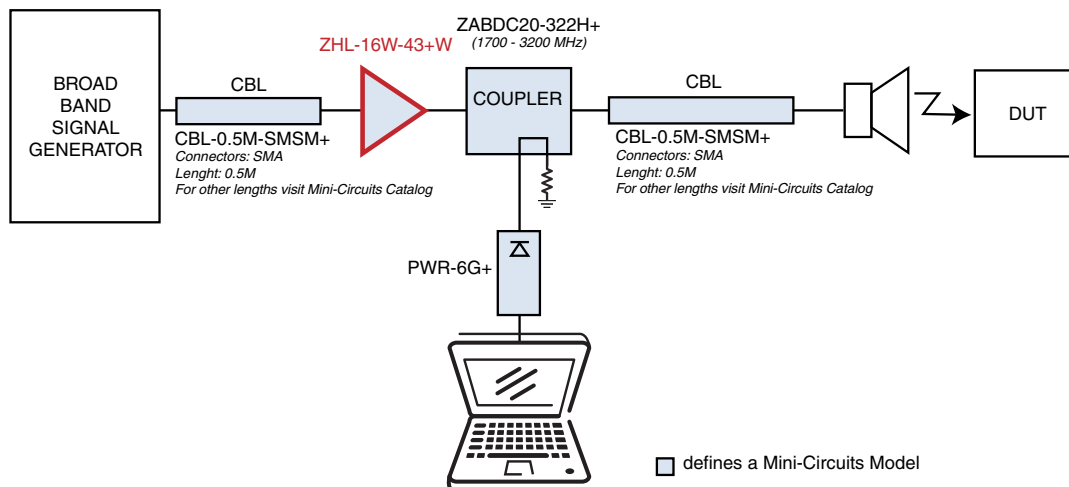

Operating over a broad range that covers many commercial radio bands, the ZHL-16W-43+ is ideal for driving susceptibility measurements.