

# Evaluation Board and Circuit

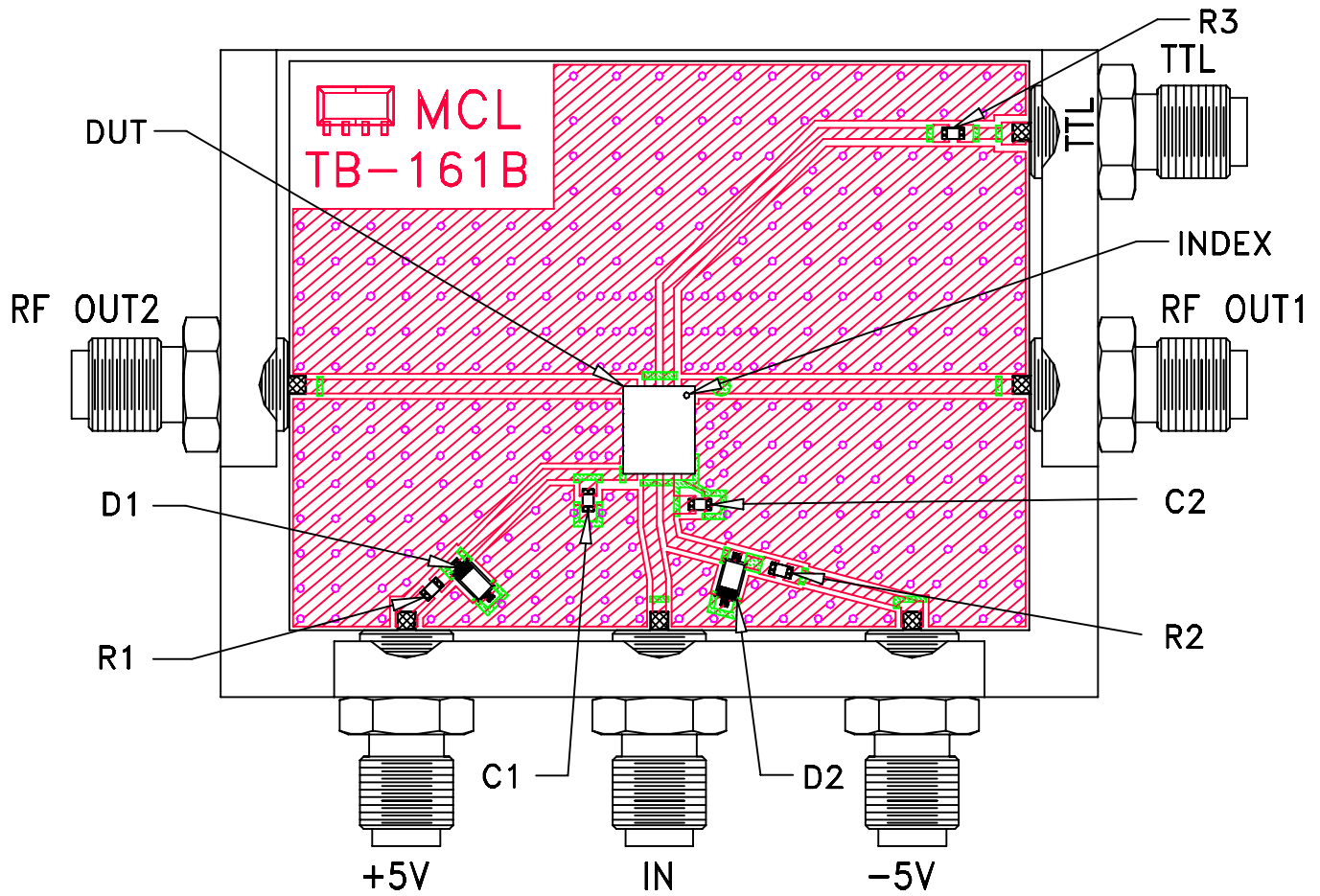

TB-161-2+

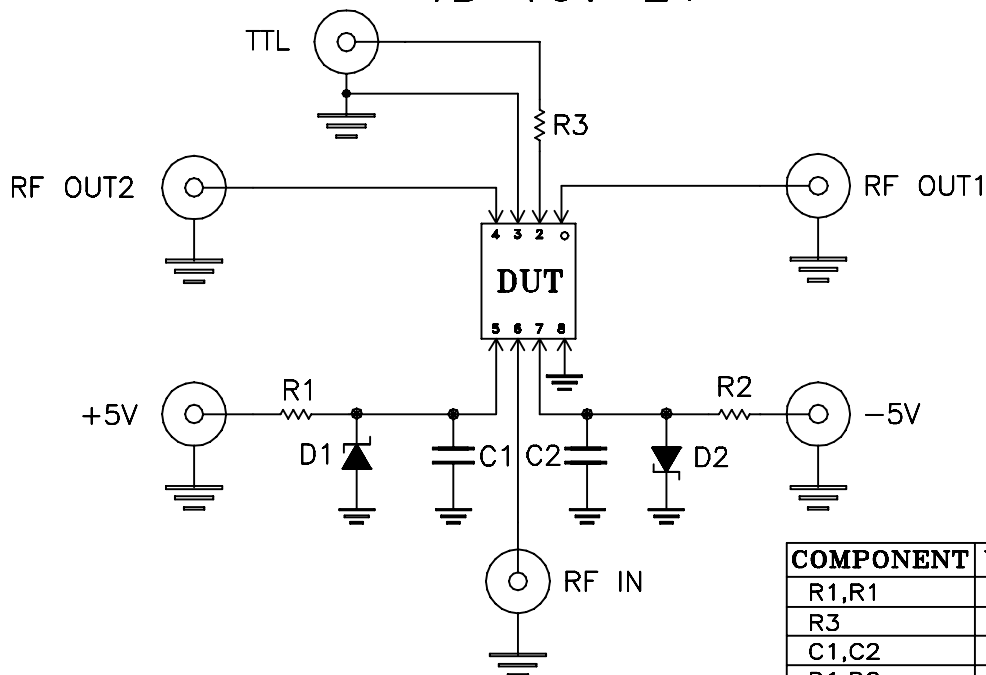

Schematic Diagram

COMPONENT	VALUE/PART #
R1,R1	11.5 Ohms
R3	100 Ohms
C1,C2	10 pF
D1,D2	5.6 V
DUT	SWMA-2-50DR+,MCL

1. SMA Female connectors.
2. PCB material: Rogers R04350 or equivalent, dielectric constant=3.5, dielectric thickness=.020 inch.

 **Mini-Circuits®**