

# Evaluation Board and Circuit

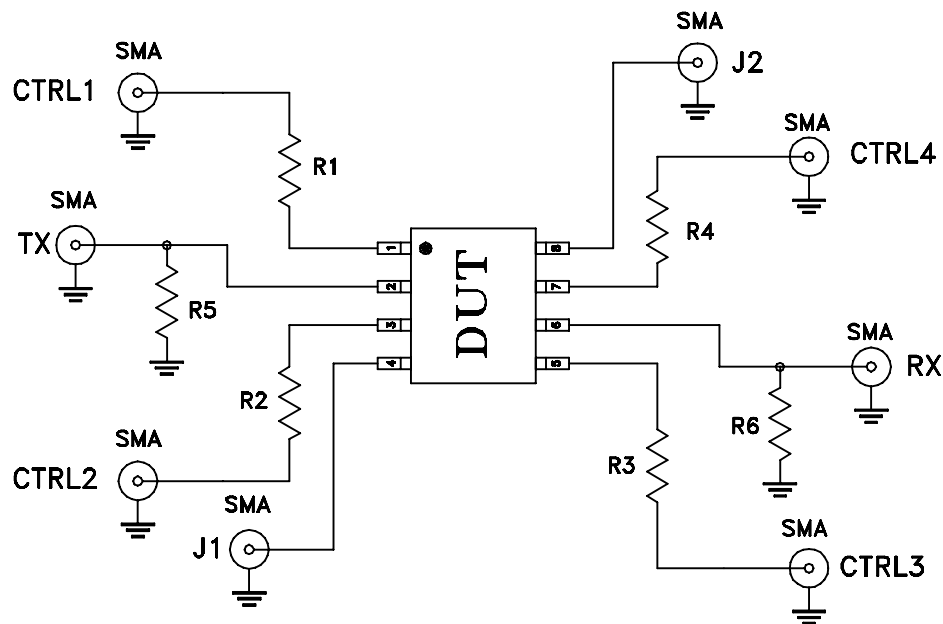
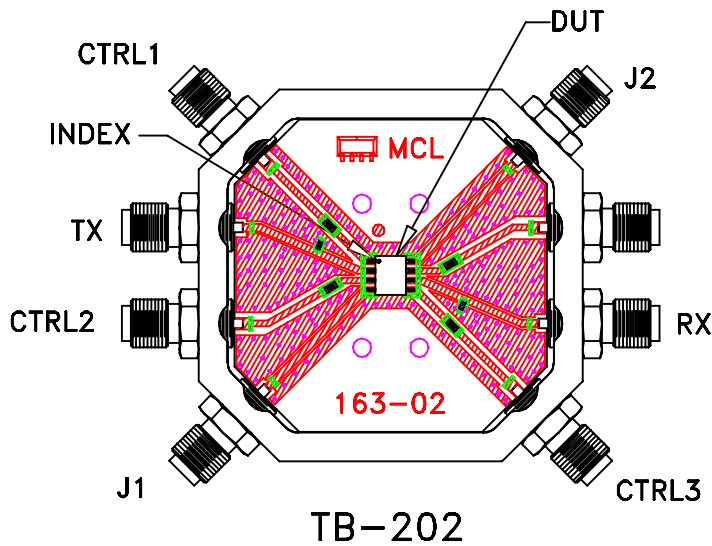

COMPONENT	VALUE
DUT	MSWT-4-20+
R1-R4	15 Ohm
R5,R6	5.62 kOhm

Schematic Diagram

## Notes:

- 50 Ohm SMA Female connectors.
- PCB Material: R04350 or equivalent.  
Dielectric Constant=3.5, Thickness=.030 inch.

 Mini-Circuits®