

Evaluation Board and Circuit

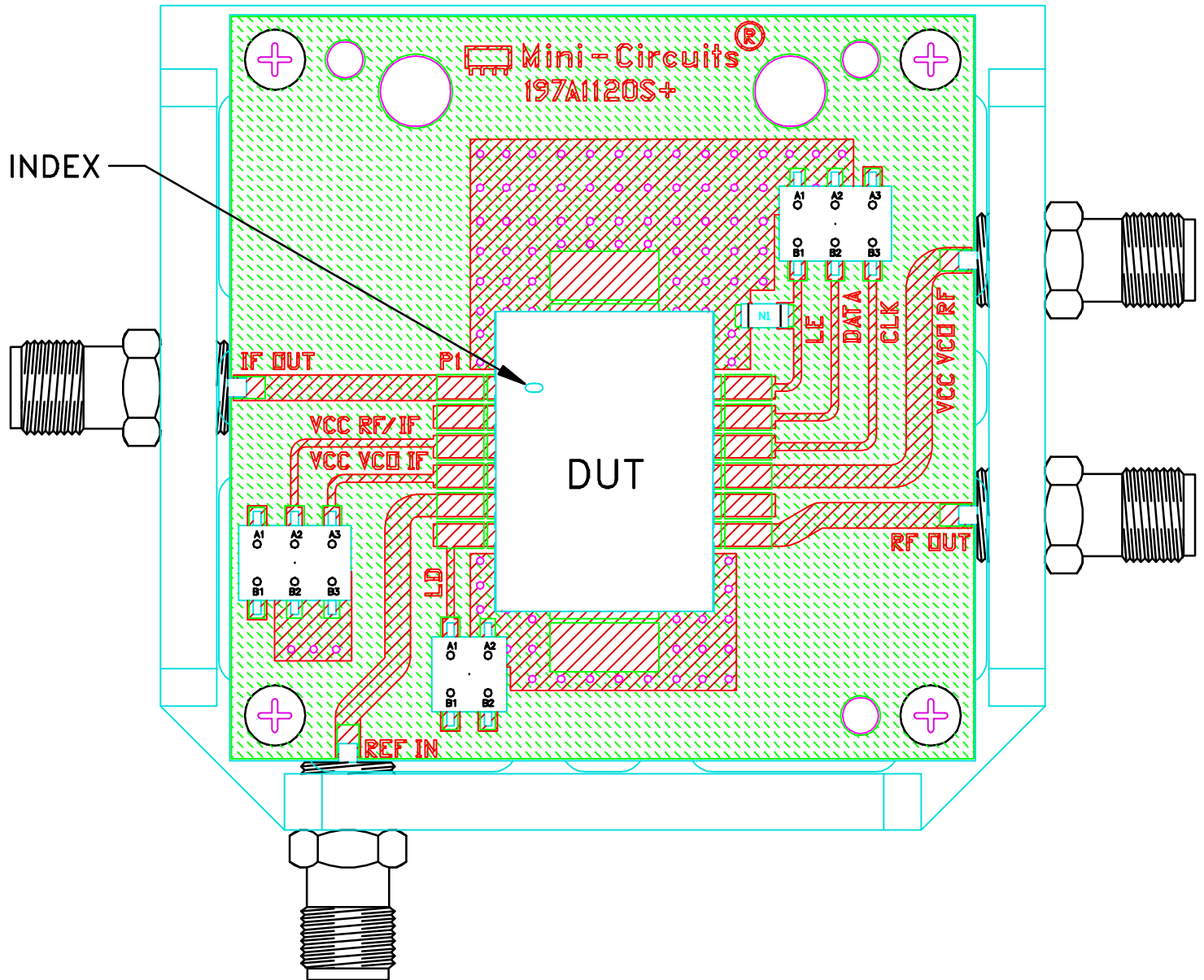

TB-595+

NOTES:

1. SMA FEMALE CONNECTORS.
2. PCB MATERIAL: RO4350B OR EQUIVALENT, DIALECTRIC CONSTANT=3.5, DIALECTRIC THICKNESS=.030 INCH.

TB-595+

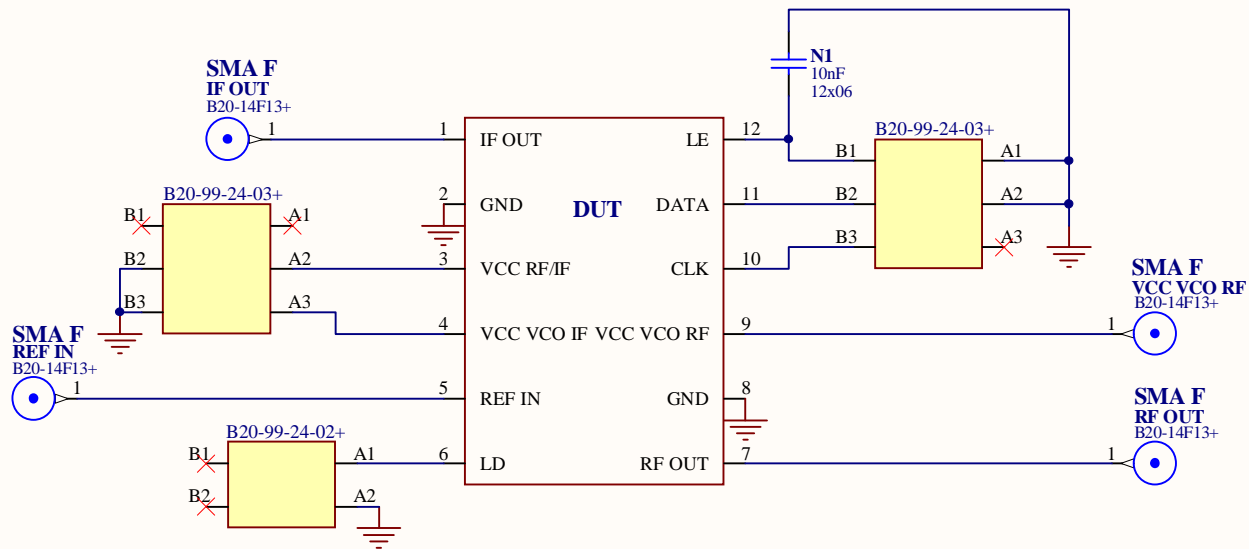

				TOLERANCES (EXCEPT AS NOTED)		
				DECIMAL ±	PART/MODEL NAME: TB-595+	SCALE: NTS
				FRACTIONAL ±	TITLE: PCB LAYOUT ELECTRICAL SCHEME	DRAWN BY: DK
YB	OR	13.09.10	R80432	ANGULAR ±		APP'D: YB
APP'D	REV	DATE	ECN#	FILE: WTB-595+	DWG No: TB-595+-21	REV: OR
					DATE: 13.09.10	SHT: 2 OF: 2