

Evaluation Board and Circuit

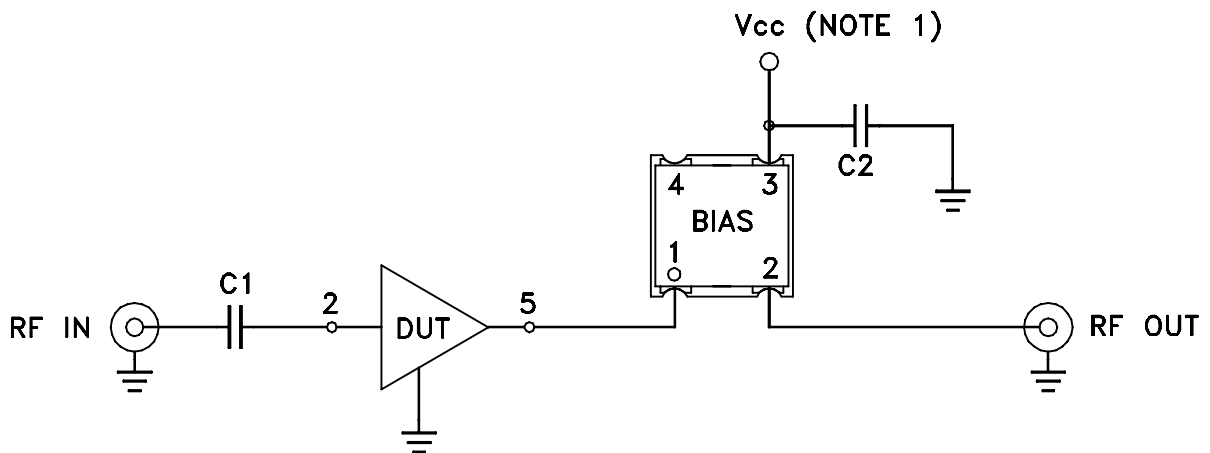
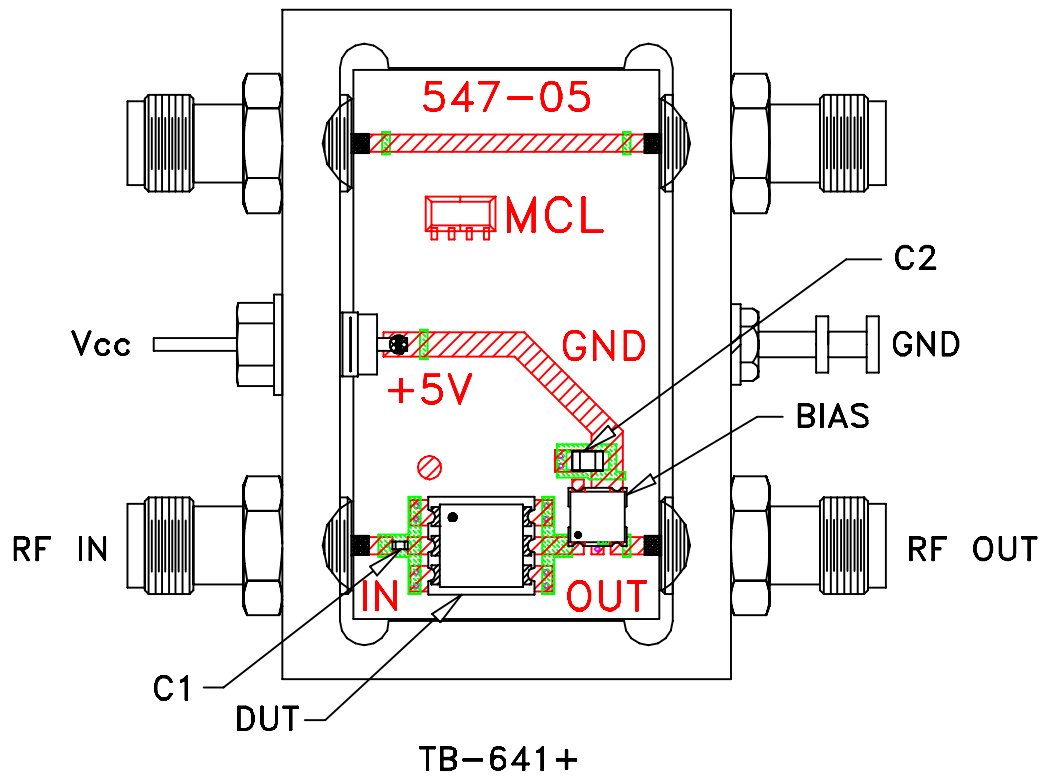

COMPONENT	DESCRIPTION
DUT	HXG-242+
C1	0.001 μ F
C2	0.01 μ F
BIAS TEE	Mini-Circuits TCBT-14+

Schematic Diagram

NOTES:

1. Vcc voltage: +5V.
2. SMA Female connectors.
3. PCB material: Rogers R04350 or equivalent, dielectric constant=3.5, dielectric thickness=.020 inch.

 Mini-Circuits®