

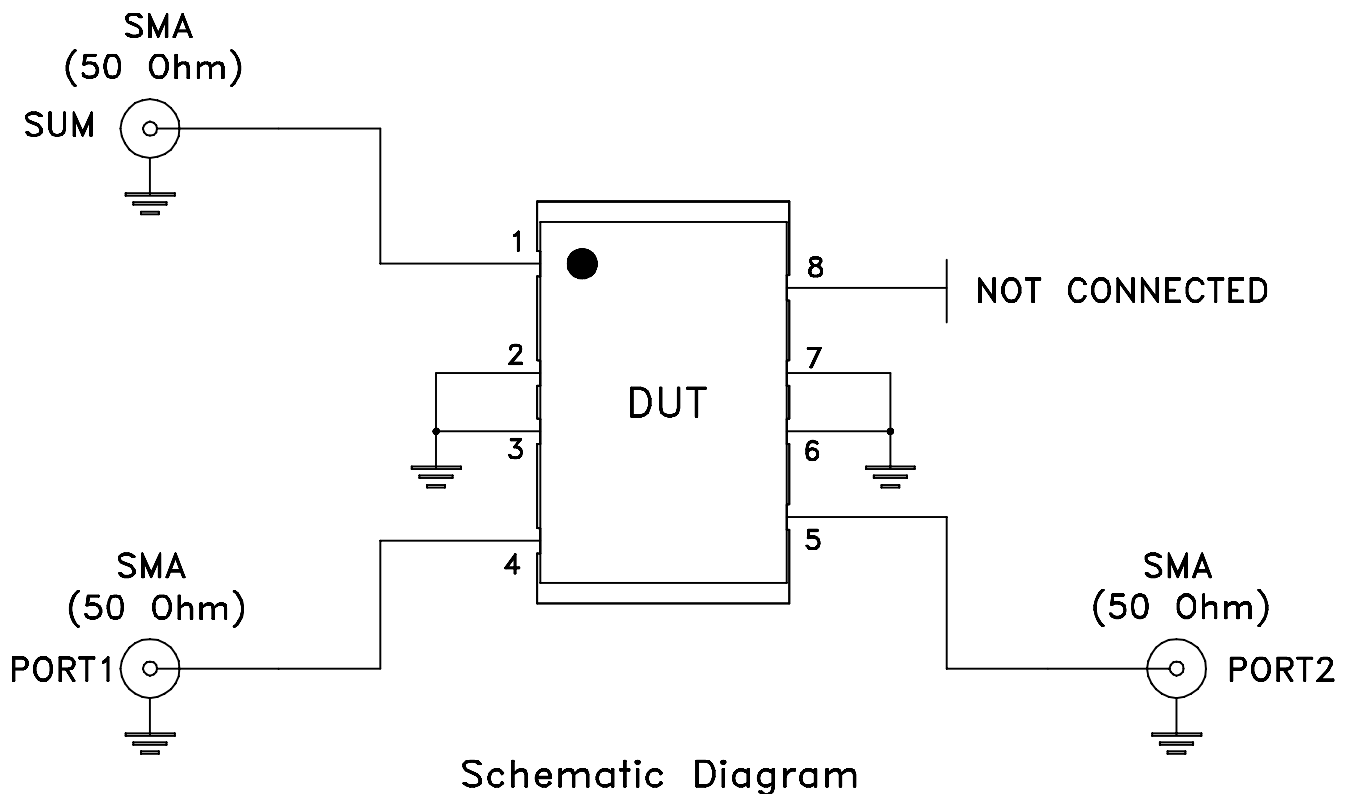

# Evaluation Board and Circuit

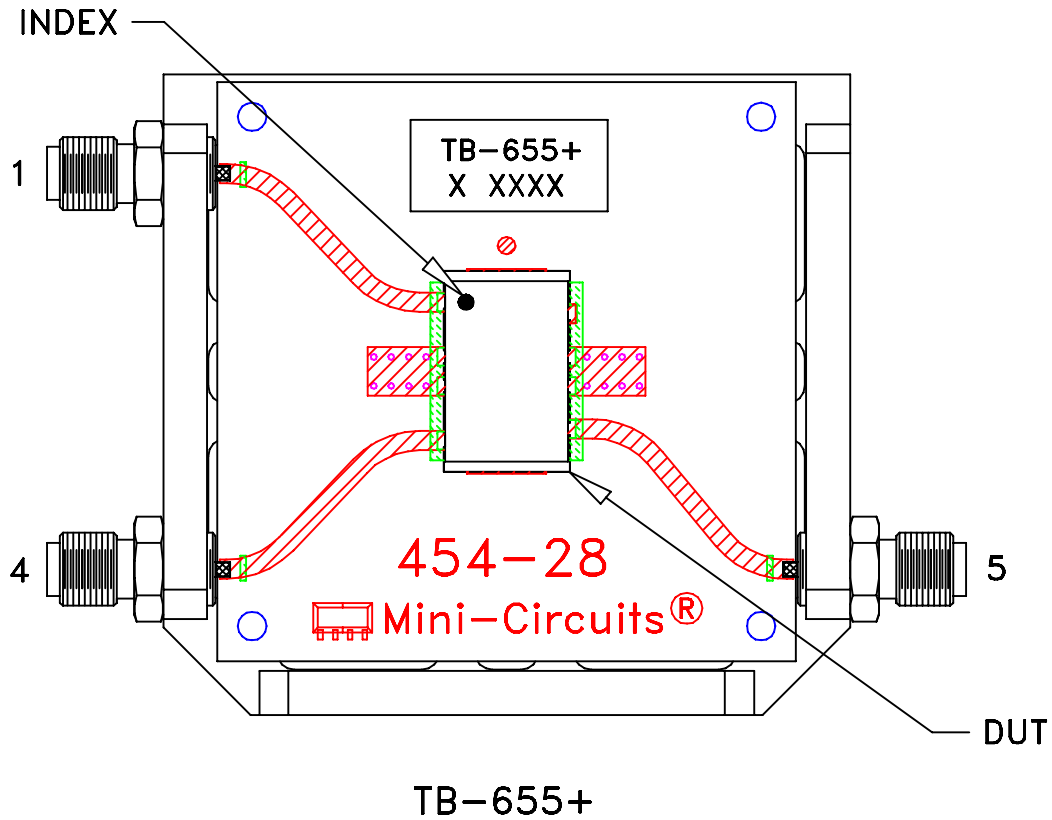

## Notes:

1. 50 Ohm SMA Female connectors.
2. PCB Material: R04350 or equivalent.  
Dielectric Constant=3.5, Thickness=.030 inch.

 **Mini-Circuits®**