

Evaluation Board and Circuit

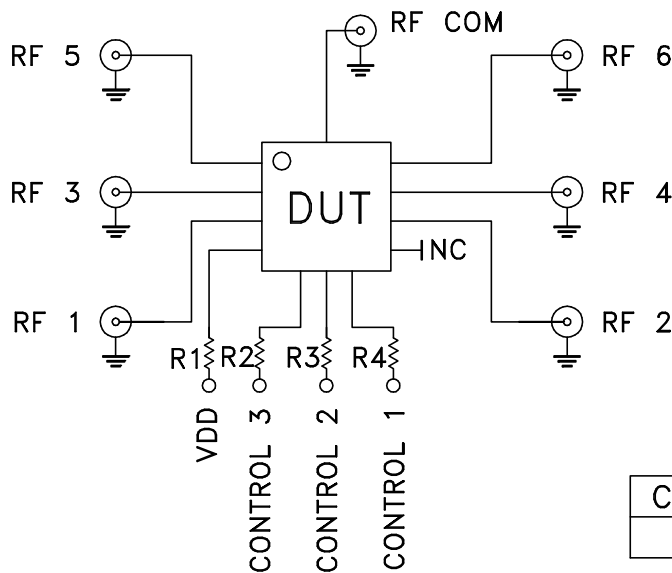
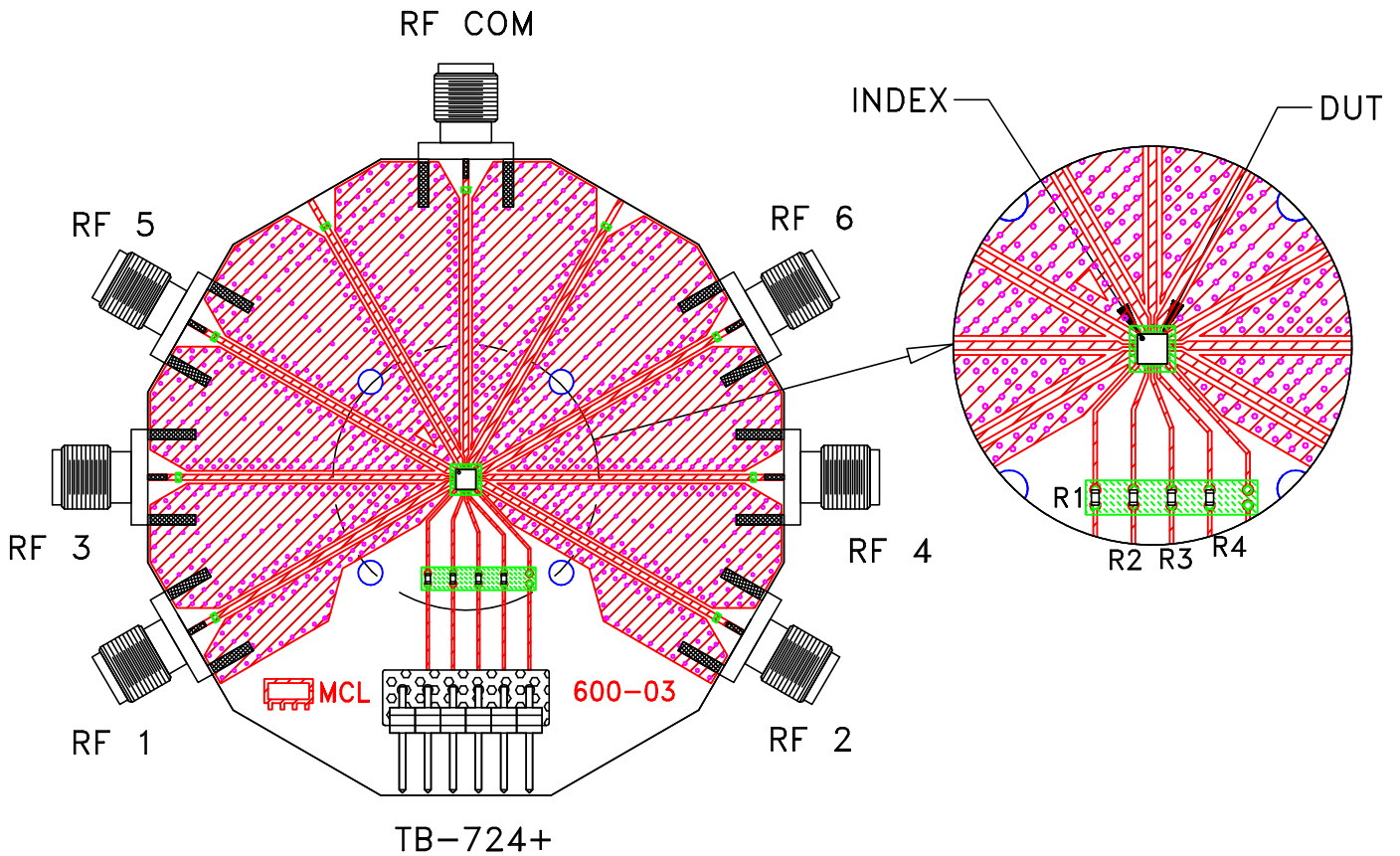

COMPONENT	VALUE	SIZE
R1-R4	1 kOhm	0402

Schematic Diagram

Notes:

1. 50 Ohm SMA Female connectors.
2. PCB Material: RO4350 or equivalent,
Dielectric Constant=3.5,
Thickness=.010 inch.

 **Mini-Circuits®**