

Evaluation Board and Circuit

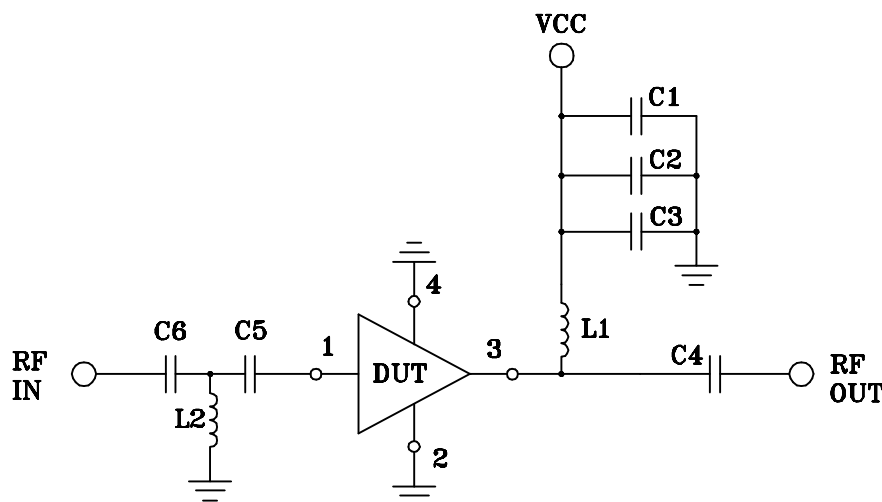
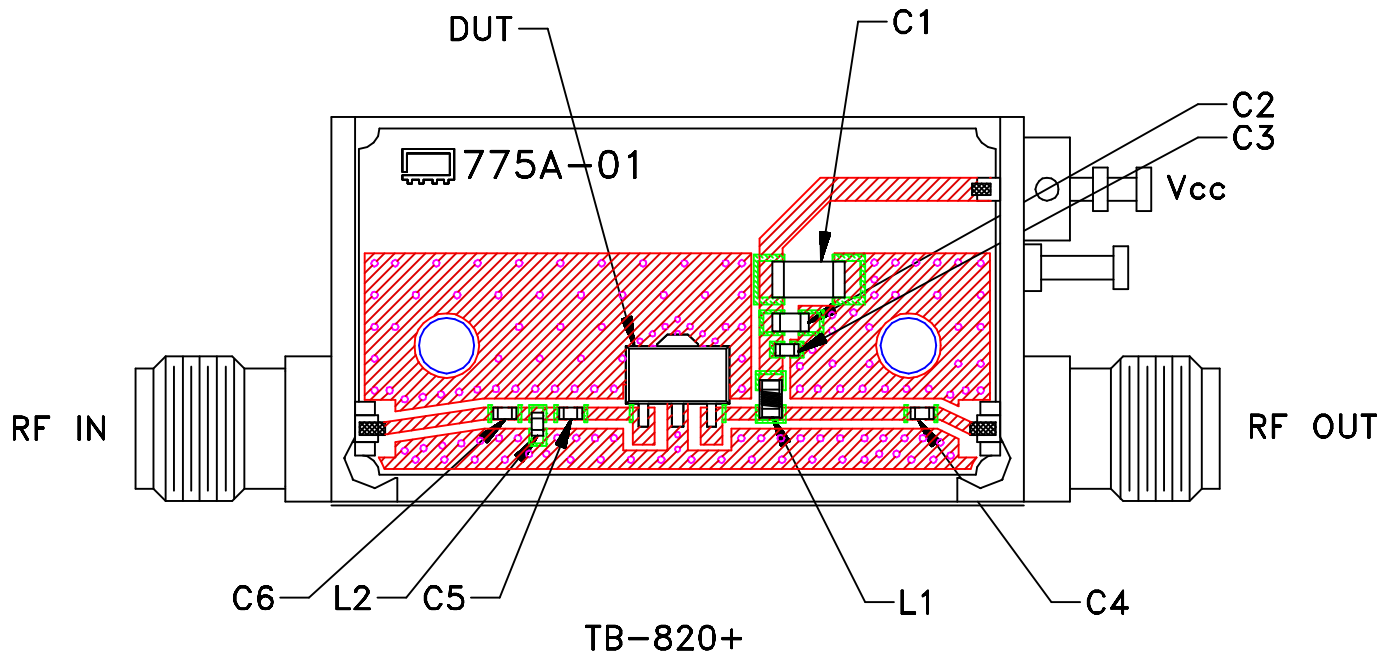

COMPONENT	SIZE	VALUE	UNITS
C1	1206	10.0	uF
C2	0603	0.1	uF
C3	0402	10.0	pF
C4,C6	0402	100.0	pF
C5	0402	5.6	pF
L1	0603	18.0	nH
L2	0402	7.5	nH

Schematic Diagram

Notes:

1. 50 Ohm SMA Female connectors.
2. PCB Material: R04350 or equivalent,
Dielectric Constant=3.5, Thickness=.010 inch.

 **Mini-Circuits®**