

# Evaluation Board and Circuit

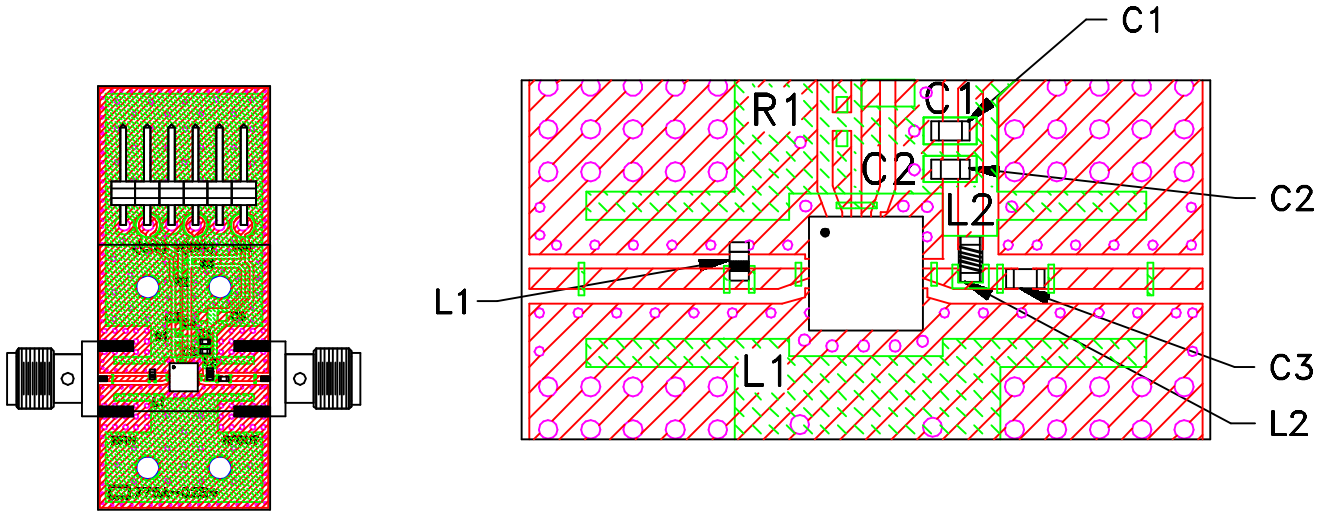

TB-830+

DETAIL "A"  
LOCATION OF COMPONENTS  
ON THE PCB  
(SCALE 2:1)

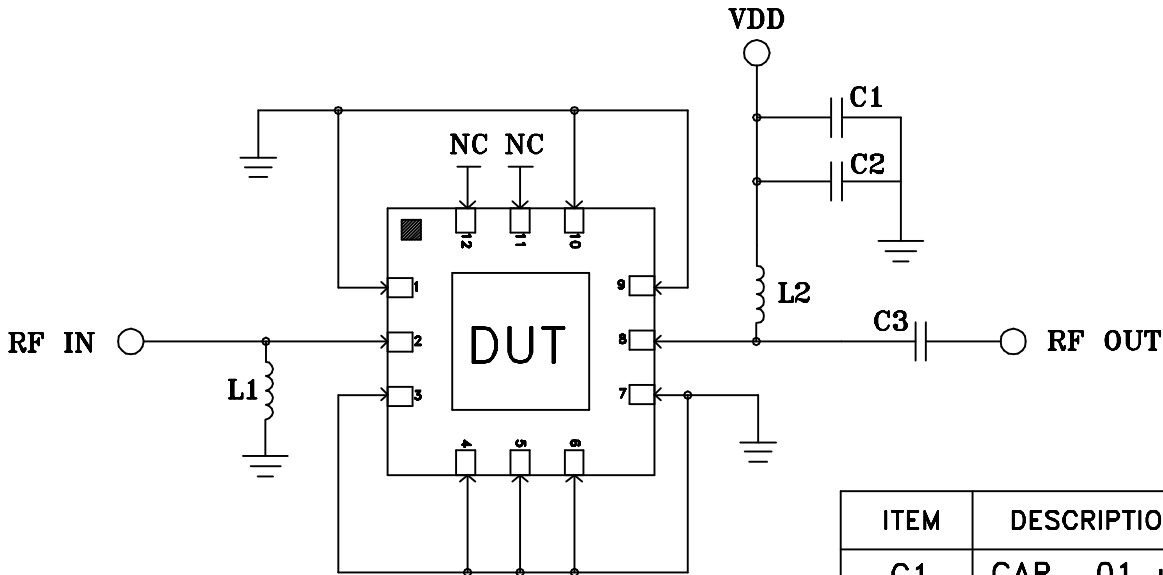

Schematic Diagram

ITEM	DESCRIPTION	SIZE
C1	CAP, .01 uF	0402
C2	CAP, 10 pF	0402
C3	CAP, 100 pF	0402
L1	IND, 18 nH	0402
L2	IND, 39 nH	0402

## Notes:

1. SMA Female Connectors.
2. PCB Material: Roger R04350B or equivalent,  
Dielectric constant=3.5, Thickness=.010 inch

 Mini-Circuits®