

# Evaluation Board and Circuit

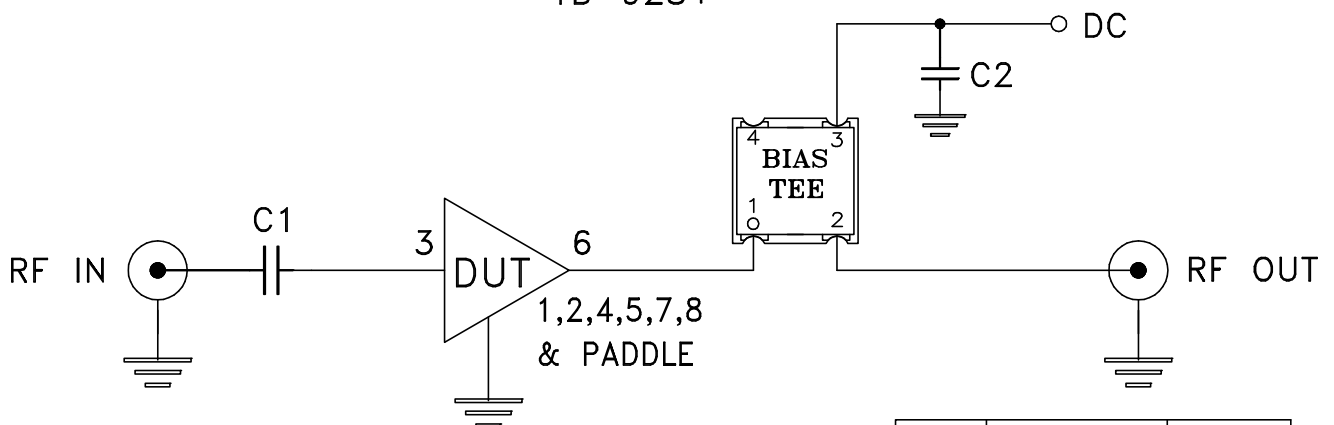

Schematic Diagram

ITEM	DESCRIPTION	SIZE
DUT	PMA2-153LN+	2X2 MM
C1	CAP, 0.1 uF	0402
C2	CAP, 0.01 uF	0603
BIAS	TCBT-153+	.15"X.15"

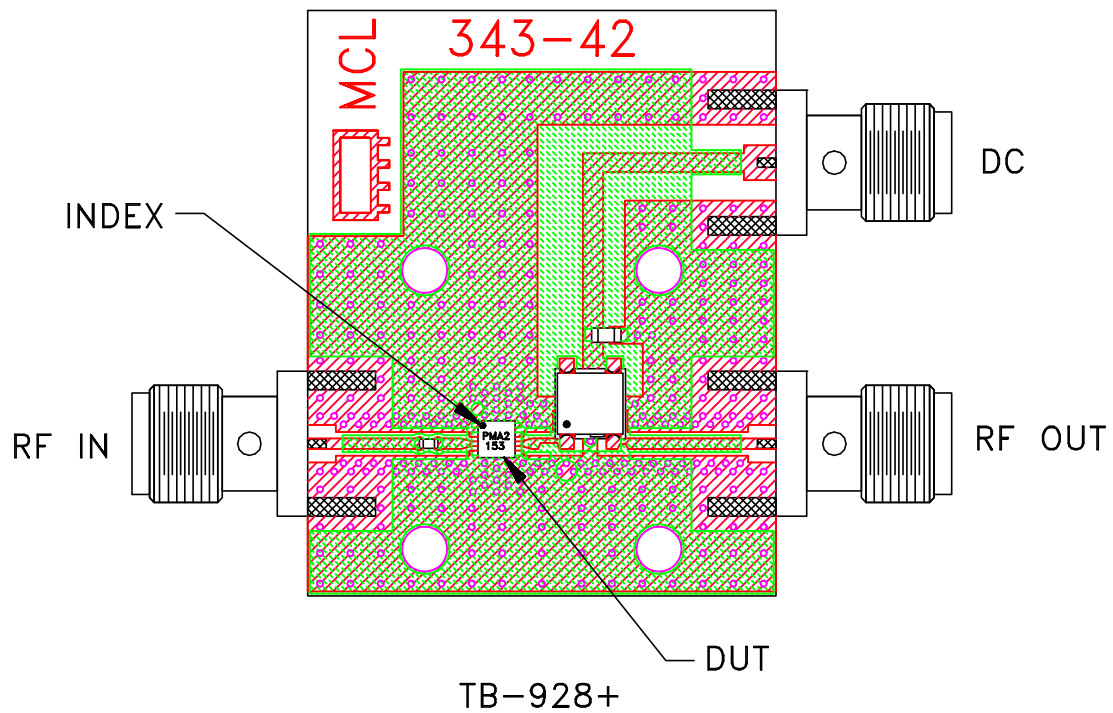
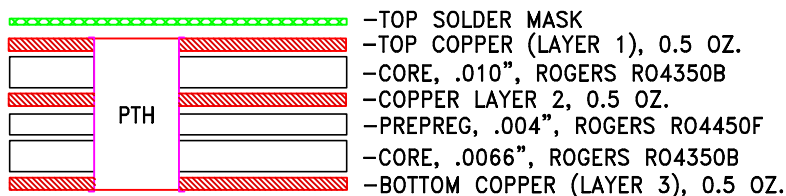

Stack-up Diagram

## Notes:

1. 50 Ohm SMA Female connectors.
2. PCB Material: R04350 or equivalent, Dielectric Constant=3.5, Thickness=.026 inch.

 **Mini-Circuits®**