

Frequency Synthesizer

KSN-1807A-519+

50Ω 1747 to 1807 MHz

The Big Deal

- Low phase noise and spurious
- Robust design and construction
- Small size 0.80" x 0.58" x 0.15"



CASE STYLE: DK1042

Product Overview

The KSN-1807A-519+ is a Frequency Synthesizer, designed to operate from 1747 to 1807 MHz for W-CDMA application. The KSN-1807A-519+ is packaged in a metal case (size of 0.80" x 0.58" x 0.15") to shield against unwanted signals and noise.

Key Features

Feature	Advantages
Low phase noise and spurious: <ul style="list-style-type: none">• Phase Noise: -95 dBc/Hz typ. @ 10 kHz offset• Comparison Spurious: -98 dBc typ.• Reference Spurious: -102 dBc typ.	Low phase noise and spurious improve system EVM (Error Vector Magnitude).
Robust design and construction	To enhance the robustness of KSN-1807A-519+, each internal component is secured to the substrate with chip bonder, thereby eliminating the risk of tombstoning during subsequent solder reflow operations by the customer.
Small size, 0.80" x 0.58" x 0.15"	The small size enables the KSN-1807A-519+ to be used in compact designs.

Notes

- A. Performance and quality attributes and conditions not expressly stated in this specification document are intended to be excluded and do not form a part of this specification document.
B. Electrical specifications and performance data contained in this specification document are based on Mini-Circuit's applicable established test performance criteria and measurement instructions.
C. The parts covered by this specification document are subject to Mini-Circuits standard limited warranty and terms and conditions (collectively, "Standard Terms"); Purchasers of this part are entitled to the rights and benefits contained therein. For a full statement of the Standard Terms and the exclusive rights and remedies thereunder, please visit Mini-Circuits' website at www.minicircuits.com/MCLStore/terms.jsp



www.minicircuits.com P.O. Box 350166, Brooklyn, NY 11235-0003 (718) 934-4500 sales@minicircuits.com

Surface Mount

Frequency Synthesizer

KSN-1807A-519+

50Ω 1747 to 1807 MHz



CASE STYLE: DK1042

Features

- Integrated VCO + PLL
- Low phase noise and spurious
- Robust design and construction
- Low operating voltage (VCC VCO=+5V, VCC PLL=+5V)
- Small size 0.80" x 0.58" x 0.15"

+RoHS Compliant
The +Suffix identifies RoHS Compliance. See our web site for RoHS Compliance methodologies and qualifications

Applications

- W-CDMA

General Description

The KSN-1807A-519+ is a Frequency Synthesizer, designed to operate from 1747 to 1807 MHz for W-CDMA application. The KSN-1807A-519+ is packaged in a metal case (size of 0.80" x 0.58" x 0.15") to shield against unwanted signals and noise. To enhance the robustness of KSN-1807A-519+, each internal component is secured to the substrate with chip bonder, thereby eliminating the risk of tombstoning during subsequent solder reflow operations by the customer.

Simplified Schematic

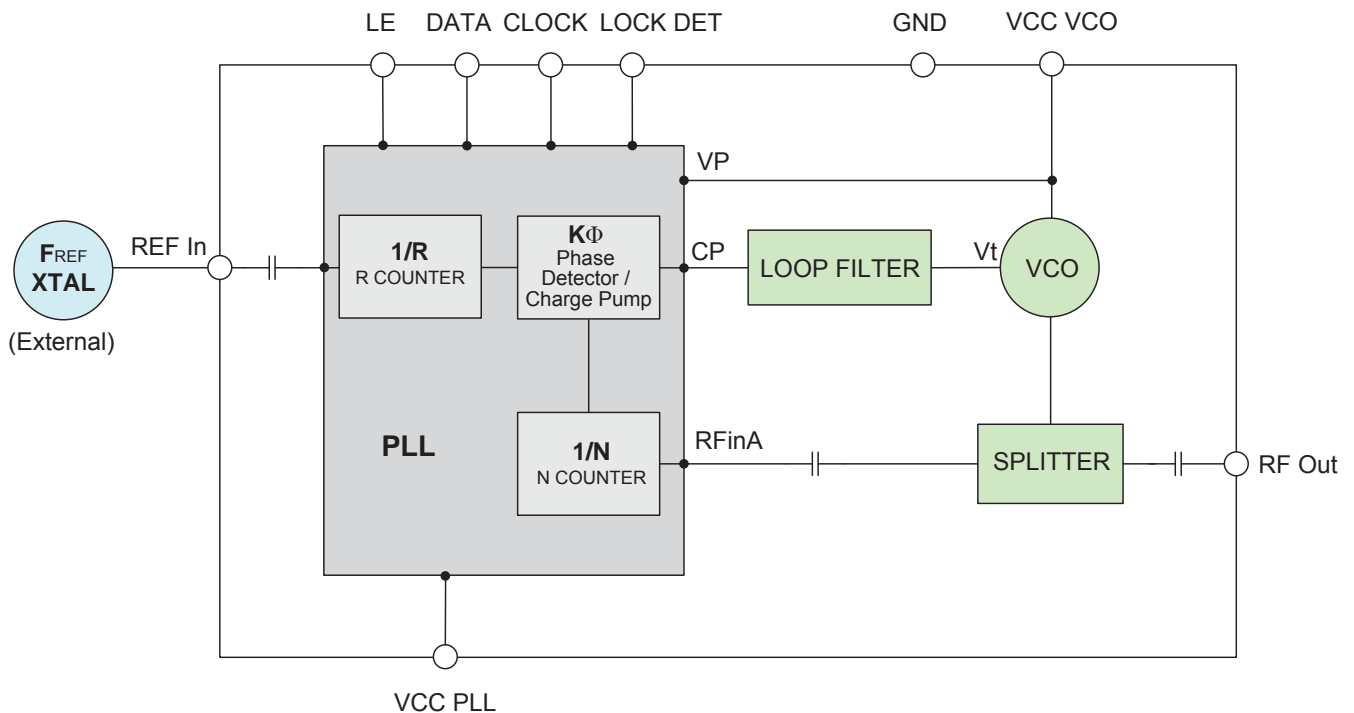

Notes

- Performance and quality attributes and conditions not expressly stated in this specification document are intended to be excluded and do not form a part of this specification document.
- Electrical specifications and performance data contained in this specification document are based on Mini-Circuit's applicable established test performance criteria and measurement instructions.
- The parts covered by this specification document are subject to Mini-Circuits standard limited warranty and terms and conditions (collectively, "Standard Terms"); Purchasers of this part are entitled to the rights and benefits contained therein. For a full statement of the Standard Terms and the exclusive rights and remedies thereunder, please visit Mini-Circuits' website at www.minicircuits.com/MCLStore/terms.jsp

Mini-Circuits
www.minicircuits.com P.O. Box 350166, Brooklyn, NY 11235-0003 (718) 934-4500 sales@minicircuits.com

REV. A
M151108
RDF-1265F1
KSN-1807A-519+
Category-A1
RAV
151014
Page 2 of 11

Electrical Specifications (over operating temperature -40°C to +85°C)

Parameters	Test Conditions	Min.	Typ.	Max.	Units	
Frequency Range	-	1747	-	1807	MHz	
Step Size	-	-	100	-	kHz	
Settling Time	Within ± 50 Hz	-	5	-	mSec	
Output Power	-	-1.5	+2.5	+3.5	dBm	
SSB Phase Noise	@ 100 Hz offset	-	-77	-	dBc/Hz	
	@ 1 kHz offset	-	-74	-67		
	@ 10 kHz offset	-	-95	-82		
	@ 100 kHz offset	-	-124	-107		
	@ 1 MHz offset	-	-147	-139		
Integrated SSB Phase Noise	@100 Hz to 5 MHz	-	-39	-36	dBc	
Reference Spurious Suppression	Ref. Freq. 10 MHz	-	-102	-	dBc	
Comparison Spurious Suppression	Step Size 100 kHz	-	-98	-		
Non - Harmonic Spurious Suppression	-	-	-90	-		
Harmonic Suppression	-	-	-41	-31		
VCO Supply Voltage	5.00	+4.75	+5.00	+5.25	V	
PLL Supply Voltage	5.00	+4.75	+5.00	+5.25		
VCO Supply Current	-	-	26	32	mA	
PLL Supply Current	-	-	7	13		
Reference Input (External)	Frequency	10 (square wave)	-	10	-	MHz
	Amplitude	1	-	1	-	V _{P-P}
	Input impedance	-	-	100	-	KΩ
	Phase Noise @ 1 kHz offset	-	-	-145	-	dBc/Hz
RF Output port Impedance	-	-	50	-	Ω	
Input Logic Level	Input high voltage	-	4.05	-	-	V
	Input low voltage	-	-	-	0.90	V
Digital Lock Detect	Locked	-	4.15	-	5.10	V
	Unlocked	-	-	-	0.4	V
Frequency Synthesizer PLL	-	ADF4118				
PLL Programming	-	3-wire serial 4.8V CMOS				
Register Map @ 1807 MHz	F_Register	-	(MSB) X0XXX00000X0010010010 (LSB)			
	N_Register	-	(MSB) 100010001101001011001 (LSB)			
	R_Register	-	(MSB) 1XXXX0000000110010000 (LSB)			

Absolute Maximum Ratings

Parameters	Ratings
VCO Supply Voltage	6.3V
PLL Supply Voltage	6.3V
VCO Supply Voltage to PLL Supply Voltage	N/A
Reference Frequency Voltage	-0.3Vmin, VCC PLL+0.1Vmax
Data, Clock, LE Levels	-0.3Vmin, VCC PLL+0.1Vmax
Operating Temperature	-40°C to +85°C
Storage Temperature	-55°C to +100°C

Permanent damage may occur if any of these limits are exceeded

Notes

- A. Performance and quality attributes and conditions not expressly stated in this specification document are intended to be excluded and do not form a part of this specification document.
- B. Electrical specifications and performance data contained in this specification document are based on Mini-Circuit's applicable established test performance criteria and measurement instructions.
- C. The parts covered by this specification document are subject to Mini-Circuits standard limited warranty and terms and conditions (collectively, "Standard Terms"); Purchasers of this part are entitled to the rights and benefits contained therein. For a full statement of the Standard Terms and the exclusive rights and remedies thereunder, please visit Mini-Circuits' website at www.minicircuits.com/MCLStore/terms.jsp



Typical Performance Data

FREQUENCY (MHz)	POWER OUTPUT (dBm)			VCO CURRENT (mA)			PLL CURENT (mA)		
	-45°C	+25°C	+85°C	-45°C	+25°C	+85°C	-45°C	+25°C	+85°C
1747	2.94	2.33	1.70	25.07	26.14	26.75	6.46	8.05	9.34
1750	2.93	2.32	1.69	25.06	26.13	26.75	6.46	8.05	9.34
1760	2.97	2.36	1.73	25.00	26.10	26.74	6.43	8.03	9.32
1770	3.01	2.40	1.77	24.96	26.08	26.72	6.45	8.04	9.33
1780	3.09	2.47	1.83	24.92	26.05	26.71	6.46	8.05	9.34
1790	3.17	2.55	1.92	24.88	26.02	26.69	6.47	8.06	9.35
1800	3.21	2.60	1.98	24.84	26.00	26.67	6.48	8.07	9.36
1807	3.22	2.61	1.99	24.80	25.97	26.65	6.48	8.07	9.37

FREQUENCY (MHz)	HARMONICS (dBc)					
	F2			F3		
	-45°C	+25°C	+85°C	-45°C	+25°C	+85°C
1747	-51.56	-42.75	-39.10	-53.72	-52.63	-56.77
1750	-50.78	-42.68	-39.21	-52.71	-52.71	-56.72
1760	-47.94	-42.77	-39.35	-54.60	-52.77	-56.05
1770	-45.78	-41.97	-38.62	-56.61	-52.47	-55.89
1780	-47.20	-42.69	-38.85	-55.20	-52.45	-57.04
1790	-49.50	-45.09	-41.16	-54.24	-51.36	-55.71
1800	-49.96	-45.87	-42.53	-52.56	-51.64	-54.71
1807	-49.56	-46.08	-42.56	-52.94	-50.94	-54.42

Notes

- A. Performance and quality attributes and conditions not expressly stated in this specification document are intended to be excluded and do not form a part of this specification document.
- B. Electrical specifications and performance data contained in this specification document are based on Mini-Circuit's applicable established test performance criteria and measurement instructions.
- C. The parts covered by this specification document are subject to Mini-Circuits standard limited warranty and terms and conditions (collectively, "Standard Terms"); Purchasers of this part are entitled to the rights and benefits contained therein. For a full statement of the Standard Terms and the exclusive rights and remedies thereunder, please visit Mini-Circuits' website at www.minicircuits.com/MCLStore/terms.jsp



FREQUENCY (MHz)	PHASE NOISE (dBc/Hz) @OFFSETS				
	+25°C				
	100Hz	1kHz	10kHz	100kHz	1MHz
1747	-74.48	-74.51	-96.58	-124.12	-146.99
1750	-76.34	-74.70	-96.38	-123.27	-146.99
1760	-80.33	-74.87	-95.51	-125.60	-147.23
1770	-78.00	-74.34	-95.35	-124.75	-147.56
1780	-76.59	-72.65	-95.85	-125.47	-147.33
1790	-78.28	-73.08	-95.26	-125.05	-147.09
1800	-78.44	-74.99	-95.14	-123.85	-147.05
1807	-77.69	-72.80	-95.05	-123.17	-147.00

FREQUENCY (MHz)	PHASE NOISE (dBc/Hz) @OFFSETS				
	-45°C				
	100Hz	1kHz	10kHz	100kHz	1MHz
1747	-76.00	-74.37	-95.34	-120.12	-146.43
1750	-74.29	-74.09	-95.09	-123.07	-146.08
1760	-75.52	-73.84	-95.15	-125.22	-146.92
1770	-78.71	-75.20	-94.45	-123.44	-146.46
1780	-74.58	-75.20	-94.36	-122.73	-146.16
1790	-74.43	-74.42	-95.57	-125.03	-147.14
1800	-76.32	-72.90	-95.11	-124.58	-147.18
1807	-79.19	-73.47	-94.80	-122.78	-146.97

FREQUENCY (MHz)	PHASE NOISE (dBc/Hz) @OFFSETS				
	+85°C				
	100Hz	1kHz	10kHz	100kHz	1MHz
1747	-74.91	-74.07	-95.84	-121.22	-146.60
1750	-77.30	-75.83	-95.92	-122.44	-146.49
1760	-76.40	-77.87	-94.96	-121.63	-146.56
1770	-76.02	-74.67	-95.64	-120.54	-146.23
1780	-75.58	-75.76	-95.31	-119.56	-146.00
1790	-77.40	-74.44	-94.75	-118.62	-146.04
1800	-73.60	-74.80	-95.07	-118.93	-145.69
1807	-74.70	-72.64	-94.99	-118.20	-145.49

Notes

- A. Performance and quality attributes and conditions not expressly stated in this specification document are intended to be excluded and do not form a part of this specification document.
- B. Electrical specifications and performance data contained in this specification document are based on Mini-Circuit's applicable established test performance criteria and measurement instructions.
- C. The parts covered by this specification document are subject to Mini-Circuits standard limited warranty and terms and conditions (collectively, "Standard Terms"); Purchasers of this part are entitled to the rights and benefits contained therein. For a full statement of the Standard Terms and the exclusive rights and remedies thereunder, please visit Mini-Circuits' website at www.minicircuits.com/MCLStore/terms.jsp



COMPARISON SPURIOUS ORDER n	COMPARISON SPURIOUS @Fcarrier 1747MHz+(n*Fcomparison) (dBc) note 1			COMPARISON SPURIOUS @Fcarrier 1777MHz+(n*Fcomparison) (dBc) note 1			COMPARISON SPURIOUS @Fcarrier 1807MHz+(n*Fcomparison) (dBc) note 1		
	-45°C	+25°C	+85°C	-45°C	+25°C	+85°C	-45°C	+25°C	+85°C
-5	-104.30	-105.68	-111.07	-105.79	-108.14	-112.48	-109.16	-114.22	-102.91
-4	-101.16	-103.58	-109.65	-102.69	-106.96	-110.06	-110.46	-110.07	-100.34
-3	-102.28	-99.41	-108.50	-101.20	-106.87	-105.44	-105.72	-106.43	-98.51
-2	-96.72	-96.10	-102.27	-102.03	-101.59	-101.53	-100.18	-102.08	-92.78
-1	-90.45	-91.22	-87.88	-90.83	-105.13	-84.45	-90.33	-98.45	-80.59
0 ^{note 2}	-	-	-	-	-	-	-	-	-
+1	-89.97	-90.63	-88.25	-89.58	-106.55	-85.03	-91.46	-99.01	-80.07
+2	-94.77	-95.63	-103.51	-101.98	-100.96	-102.54	-100.41	-104.19	-93.09
+3	-101.21	-99.38	-106.68	-101.36	-106.65	-106.01	-106.76	-108.13	-98.13
+4	-100.79	-103.24	-107.83	-101.80	-108.17	-110.71	-109.22	-111.95	-100.97
+5	-104.62	-102.90	-111.88	-106.59	-110.02	-112.89	-110.91	-112.83	-104.35

Note 1: Comparison frequency 100 kHz

Note 2: All spurs are referenced to carrier signal (n=0).

REFERENCE SPURIOUS ORDER n	REFERENCE SPURIOUS @Fcarrier 1747MHz+(n*Freference) (dBc) note 3			REFERENCE SPURIOUS @Fcarrier 1777MHz+(n*Freference) (dBc) note 3			REFERENCE SPURIOUS @Fcarrier 1807MHz+(n*Freference) (dBc) note 3		
	-45°C	+25°C	+85°C	-45°C	+25°C	+85°C	-45°C	+25°C	+85°C
-5	-127.73	-127.76	-126.41	-127.99	-127.79	-126.26	-128.65	-128.32	-126.22
-4	-128.76	-127.53	-126.70	-127.97	-127.66	-127.41	-128.96	-128.27	-126.76
-3	-127.15	-128.48	-126.62	-126.72	-128.26	-126.91	-125.96	-128.80	-126.30
-2	-127.12	-123.58	-122.24	-128.72	-125.43	-122.55	-125.01	-127.50	-125.40
-1	-105.25	-104.07	-103.83	-106.68	-103.40	-104.81	-105.79	-104.02	-103.97
0 ^{note 4}	-	-	-	-	-	-	-	-	-
+1	-102.65	-100.89	-101.82	-103.74	-100.58	-102.85	-103.45	-100.53	-102.04
+2	-124.17	-120.26	-121.14	-127.04	-120.54	-121.25	-128.05	-122.75	-123.40
+3	-119.74	-119.33	-120.70	-123.58	-122.56	-121.17	-122.97	-121.65	-119.30
+4	-123.12	-124.96	-126.25	-127.17	-125.70	-127.15	-126.21	-125.41	-126.11
+5	-123.66	-126.05	-126.50	-127.19	-128.08	-124.54	-127.72	-127.82	-124.40

Note 3: Reference frequency 10 MHz

Note 4: All spurs are referenced to carrier signal (n=0).

Notes

- A. Performance and quality attributes and conditions not expressly stated in this specification document are intended to be excluded and do not form a part of this specification document.
- B. Electrical specifications and performance data contained in this specification document are based on Mini-Circuit's applicable established test performance criteria and measurement instructions.
- C. The parts covered by this specification document are subject to Mini-Circuits standard limited warranty and terms and conditions (collectively, "Standard Terms"); Purchasers of this part are entitled to the rights and benefits contained therein. For a full statement of the Standard Terms and the exclusive rights and remedies thereunder, please visit Mini-Circuits' website at www.minicircuits.com/MCLStore/terms.jsp



Typical Performance Curves

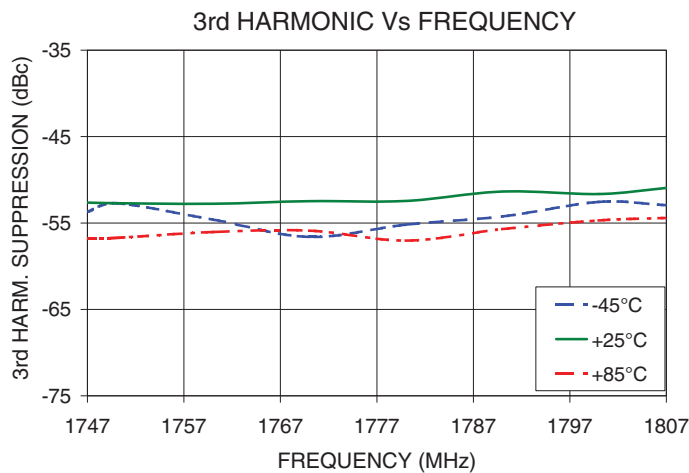
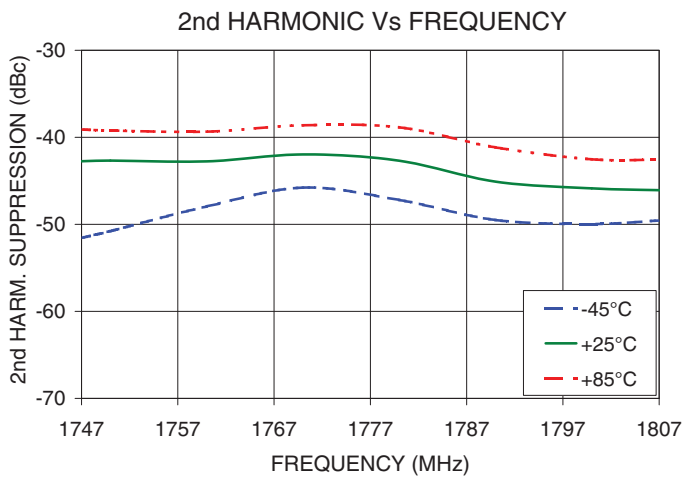
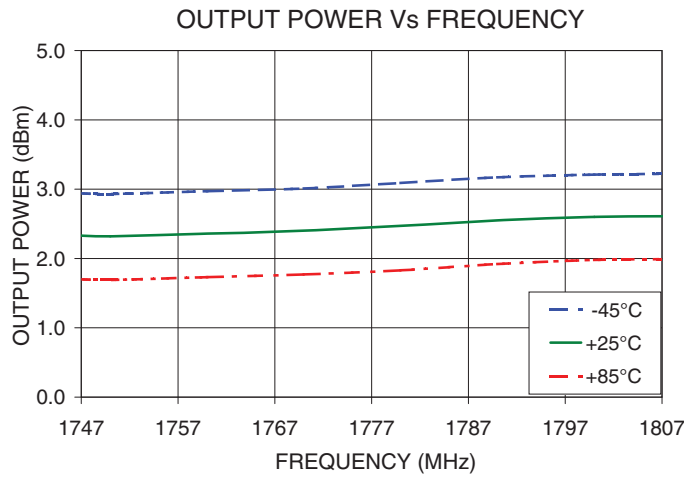

Notes

- A. Performance and quality attributes and conditions not expressly stated in this specification document are intended to be excluded and do not form a part of this specification document.
- B. Electrical specifications and performance data contained in this specification document are based on Mini-Circuit's applicable established test performance criteria and measurement instructions.
- C. The parts covered by this specification document are subject to Mini-Circuits standard limited warranty and terms and conditions (collectively, "Standard Terms"); Purchasers of this part are entitled to the rights and benefits contained therein. For a full statement of the Standard Terms and the exclusive rights and remedies thereunder, please visit Mini-Circuits' website at www.minicircuits.com/MCLStore/terms.jsp



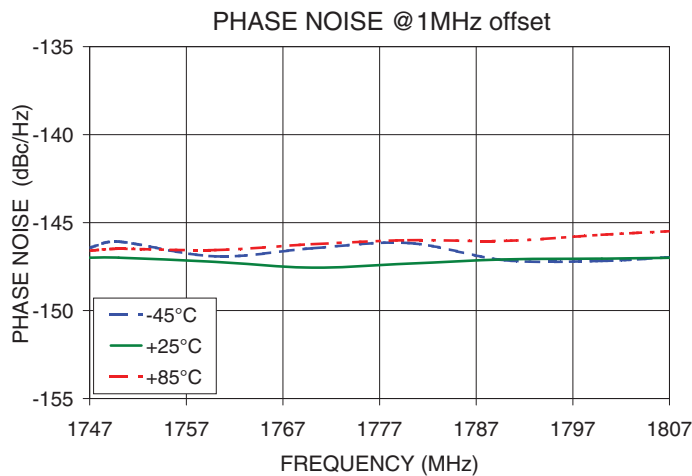
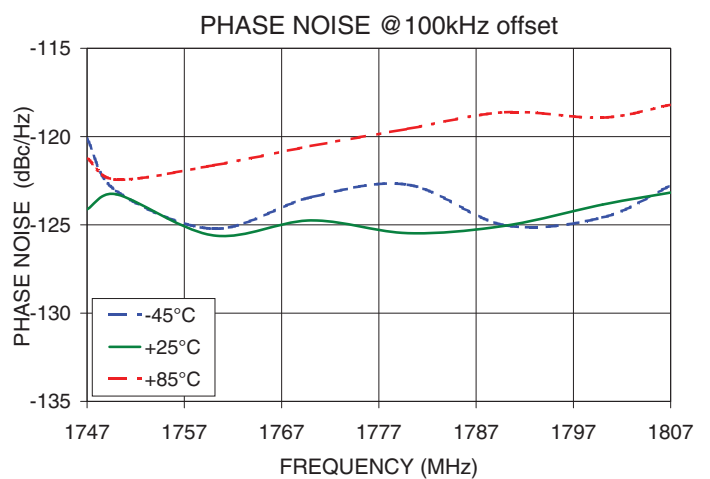
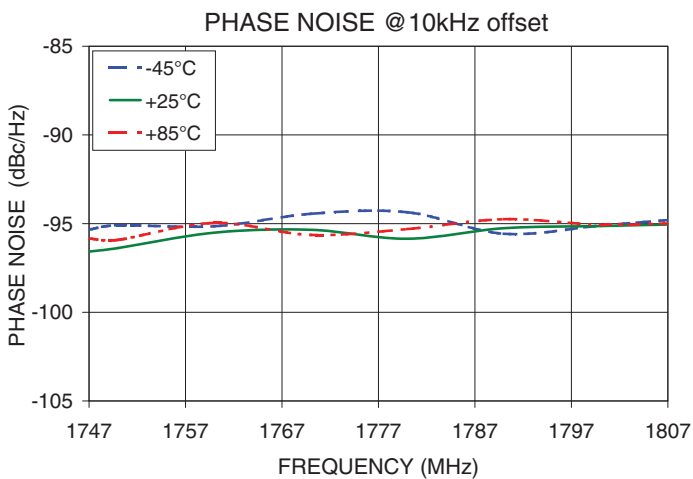
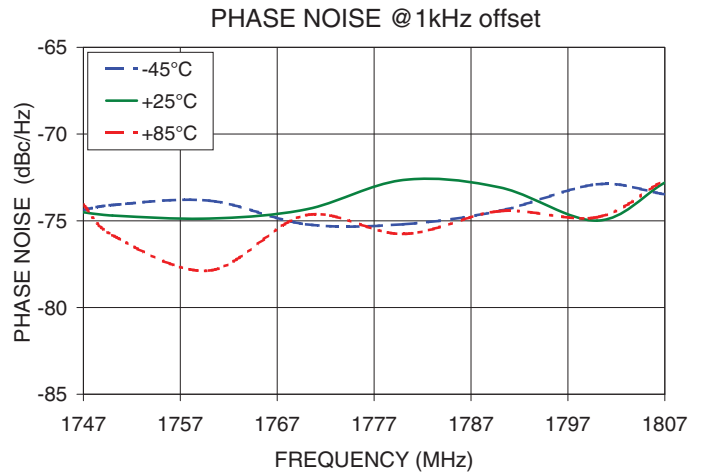
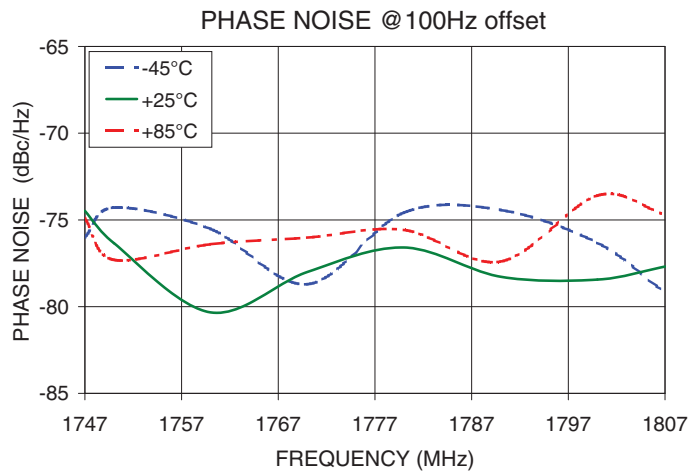

Notes

- A. Performance and quality attributes and conditions not expressly stated in this specification document are intended to be excluded and do not form a part of this specification document.
- B. Electrical specifications and performance data contained in this specification document are based on Mini-Circuit's applicable established test performance criteria and measurement instructions.
- C. The parts covered by this specification document are subject to Mini-Circuits standard limited warranty and terms and conditions (collectively, "Standard Terms"); Purchasers of this part are entitled to the rights and benefits contained therein. For a full statement of the Standard Terms and the exclusive rights and remedies thereunder, please visit Mini-Circuits' website at www.minicircuits.com/MCLStore/terms.jsp



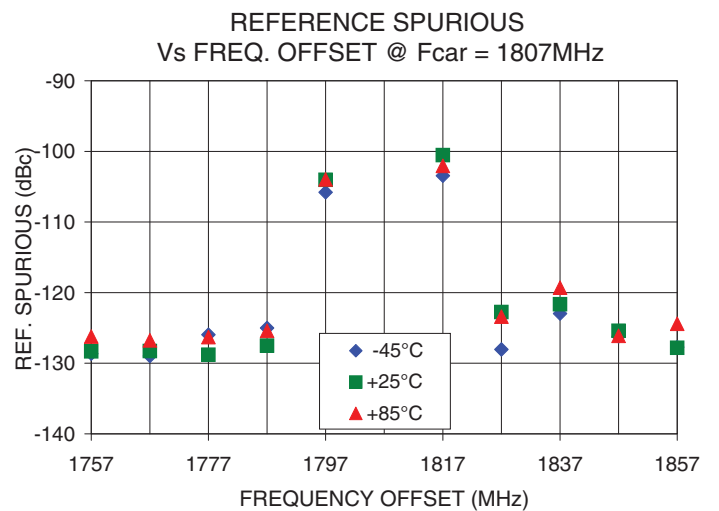
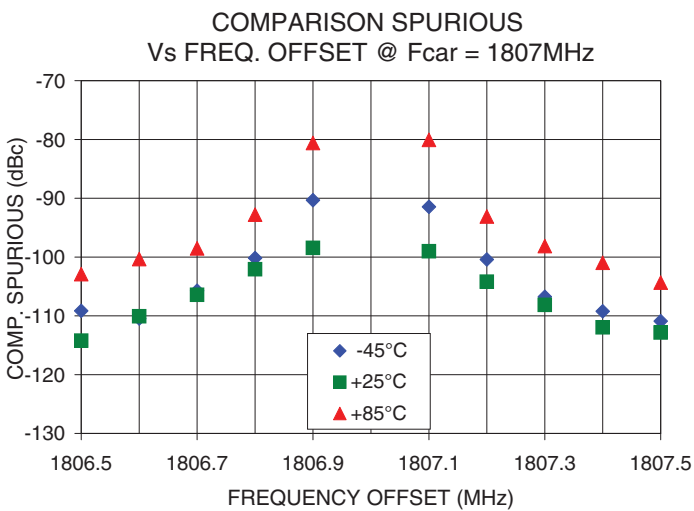
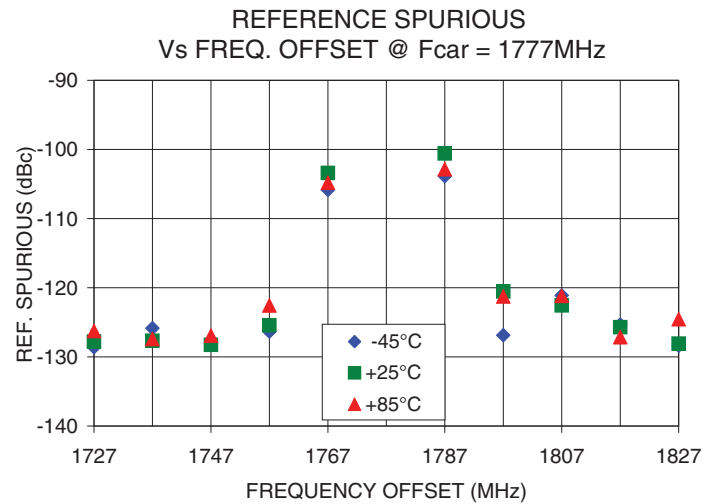
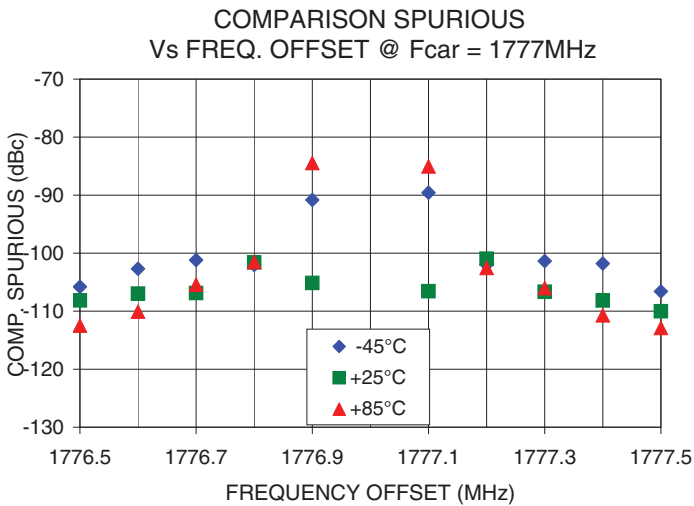
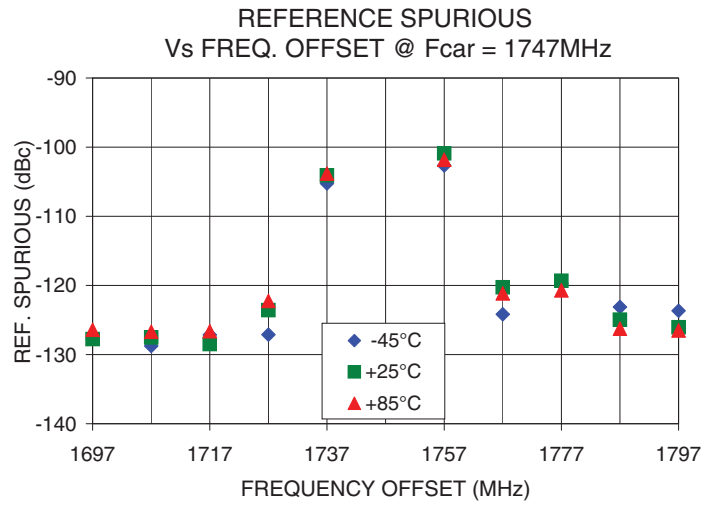
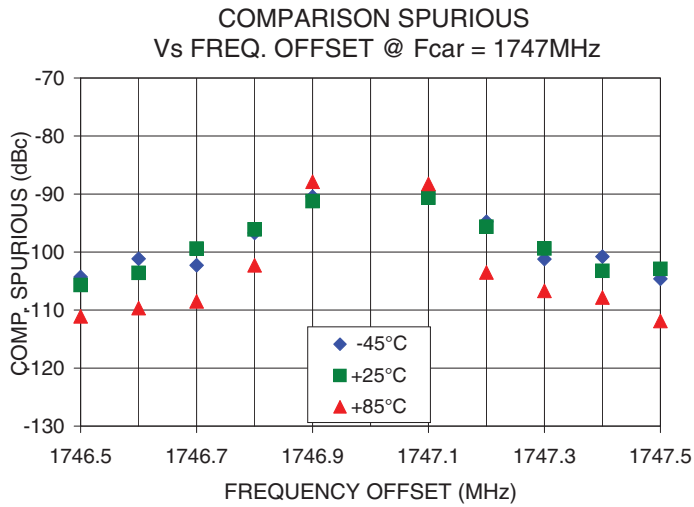

Notes

- A. Performance and quality attributes and conditions not expressly stated in this specification document are intended to be excluded and do not form a part of this specification document.
- B. Electrical specifications and performance data contained in this specification document are based on Mini-Circuit's applicable established test performance criteria and measurement instructions.
- C. The parts covered by this specification document are subject to Mini-Circuits standard limited warranty and terms and conditions (collectively, "Standard Terms"); Purchasers of this part are entitled to the rights and benefits contained therein. For a full statement of the Standard Terms and the exclusive rights and remedies thereunder, please visit Mini-Circuits' website at www.minicircuits.com/MCLStore/terms.jsp



Pin Configuration

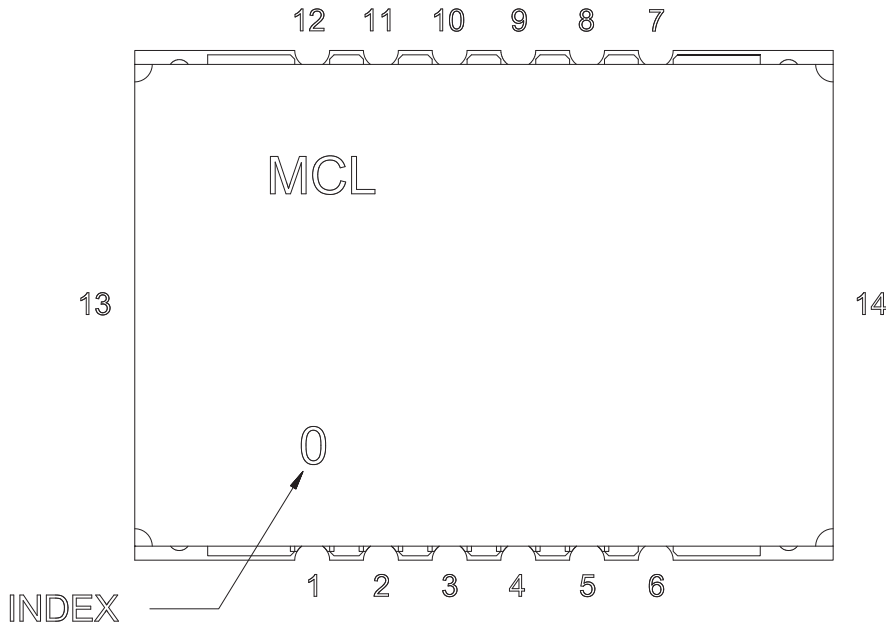

Pin Connection

Pin Number	Function
1	VCC PLL
2	GND
3	REF IN
4	GND
5	VCC VCO
6	GND
7	RF OUT
8	GND
9	LOCK DET
10	CLOCK
11	DATA
12	LE
13	GND
14	GND

Recommended Application Circuit

Note: REF IN and RF OUT ports are internally AC coupled.

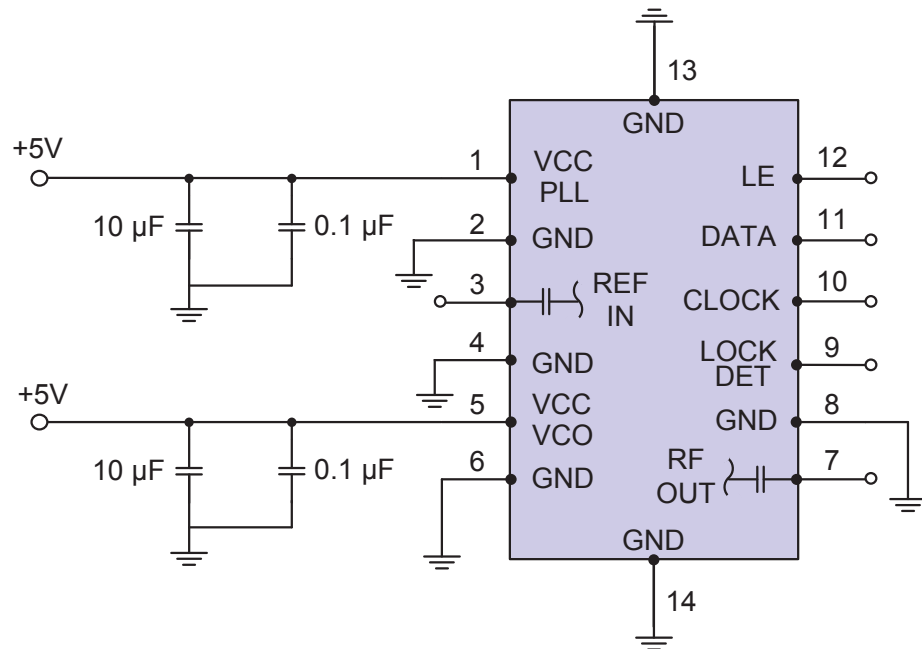

Notes

- A. Performance and quality attributes and conditions not expressly stated in this specification document are intended to be excluded and do not form a part of this specification document.
- B. Electrical specifications and performance data contained in this specification document are based on Mini-Circuit's applicable established test performance criteria and measurement instructions.
- C. The parts covered by this specification document are subject to Mini-Circuits standard limited warranty and terms and conditions (collectively, "Standard Terms"); Purchasers of this part are entitled to the rights and benefits contained therein. For a full statement of the Standard Terms and the exclusive rights and remedies thereunder, please visit Mini-Circuits' website at www.minicircuits.com/MCLStore/terms.jsp



Device Marking

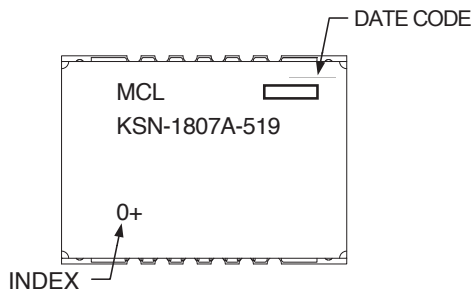

Additional Detailed Technical Information

Additional information is available on our web site. To access this information enter the model number on our web site home page.

Case Style: DK1042

Tape & Reel: TR-F28

Suggested Layout for PCB Design: PL-249

Evaluation Board: TB-567+

Environment Ratings: ENV65T2

Notes

- Performance and quality attributes and conditions not expressly stated in this specification document are intended to be excluded and do not form a part of this specification document.
- Electrical specifications and performance data contained in this specification document are based on Mini-Circuit's applicable established test performance criteria and measurement instructions.
- The parts covered by this specification document are subject to Mini-Circuits standard limited warranty and terms and conditions (collectively, "Standard Terms"); Purchasers of this part are entitled to the rights and benefits contained therein. For a full statement of the Standard Terms and the exclusive rights and remedies thereunder, please visit Mini-Circuits' website at www.minicircuits.com/MCLStore/terms.jsp

