

Surface Mount

NON-CATALOG

Power Splitter/Combiner

LRPS-2-11

2 Way-0° 50Ω 20 to 2000 MHz



CASE STYLE: QQQ130

Maximum Ratings

Operating Temperature	-40°C to 85°C
Storage Temperature	-55°C to 100°C
Power Input (as a splitter)	1W max.
Internal Dissipation	0.125W max.

Pin Connections

SUM PORT	6
PORT 1	4
PORT 2	3
GROUND	1,2,5

Outline Drawing

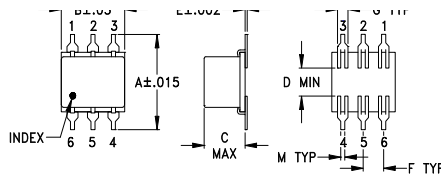

PCB Land Pattern

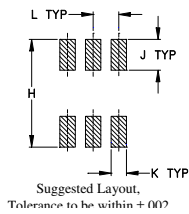

Outline Dimensions (inch/mm)

A	B	C	D	E	F	G
.400	.31	.200	.10	.010	.100	.050
10.16	7.87	5.08	2.54	0.25	2.54	1.27
H	J	K	L	M		wt
.420	.120	.060	.100	.020		grams
10.67	3.05	1.52	2.54	0.51		0.55

Demo Board MCL P/N: TB-100 Suggested PCB Layout (PL-057)

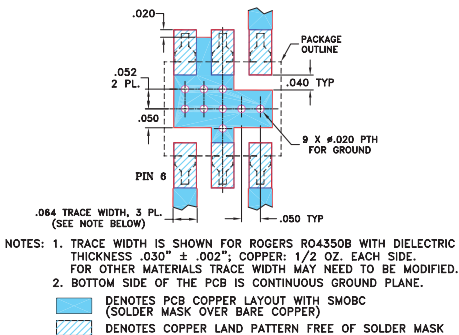

Features

- very wideband, 20 to 2000 MHz
- low insertion loss, 0.7 dB typ.
- good isolation, 21 dB typ.

Applications

- cellular
- GPS
- communications systems

Electrical Specifications

FREQ. RANGE (MHz)	ISOLATION (dB)						INSERTION LOSS (dB) ABOVE 3.0 dB						PHASE UNBALANCE (Degrees)			AMPLITUDE UNBALANCE (dB)		
	L		M		U		L		M		U		L	M	U	L	M	U
	Typ.	Min.	Typ.	Min.	Typ.	Min.	Typ.	Max.	Typ.	Max.	Typ.	Max.	Max.	Max.	Max.	Max.	Max.	Max.
20-2000	19	15	21	15	30	15	0.6	0.8	0.7	1.0	0.8	1.5	2.0	3.0	5.0	0.2	0.3	0.7

L = 20-200 MHz M = 200-1000 MHz U = 1000-2000 MHz

Typical Performance Data

Frequency (MHz)	Insertion Loss (dB)		Amplitude Unbalance (dB)	Isolation (dB)	Phase Unbalance (deg.)	VSWR S	VSWR 1	VSWR 2
	S-1	S-2						
20.00	3.57	3.55	0.01	18.82	0.10	1.98	1.58	1.58
60.00	3.58	3.57	0.01	18.71	0.18	1.96	1.58	1.57
100.00	3.59	3.59	0.01	18.70	0.29	1.95	1.58	1.58
160.00	3.61	3.59	0.02	18.72	0.45	1.94	1.58	1.58
300.00	3.63	3.64	0.01	18.84	0.77	1.91	1.58	1.59
600.00	3.65	3.65	0.00	19.55	1.46	1.84	1.57	1.59
800.00	3.65	3.63	0.02	20.59	1.76	1.76	1.56	1.59
950.00	3.65	3.60	0.05	21.89	1.90	1.71	1.55	1.58
1150.00	3.65	3.56	0.09	24.73	1.89	1.62	1.53	1.56
1300.00	3.67	3.64	0.03	28.68	1.70	1.53	1.52	1.54
1450.00	3.72	3.60	0.12	37.99	1.45	1.46	1.50	1.51
1600.00	3.78	3.73	0.05	34.62	1.03	1.42	1.49	1.48
1850.00	3.94	3.83	0.11	22.22	0.16	1.45	1.47	1.40
1950.00	4.01	3.94	0.07	19.58	0.70	1.51	1.46	1.36
2000.00	4.03	4.02	0.01	18.65	0.98	1.55	1.46	1.34

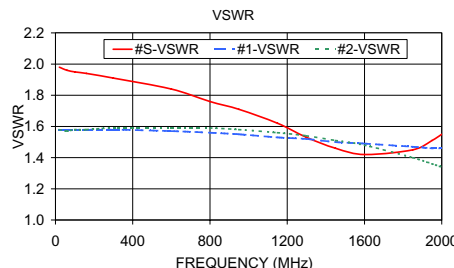
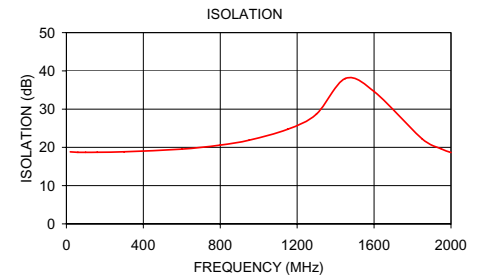
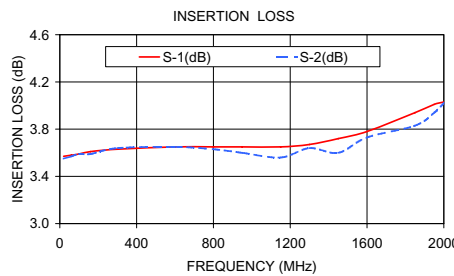

electrical schematic

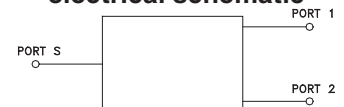

Mini-Circuits®
ISO 9001 ISO 14001 AS 9100 CERTIFIED

minicircuits.com

P.O. Box 350166, Brooklyn, New York 11235-0003 (718) 934-4500 Fax (718) 332-4661 For detailed performance specs & shopping online see Mini-Circuits web site

The Design Engineers Search Engine Provides ACTUAL Data Instantly From MINI-CIRCUITS At: www.minicircuits.com

REV. A
M120055
LRPS-2-11
ED-2361
D.J.TD/CP/AM
090119

IF/RF MICROWAVE COMPONENTS