

High Directivity

Monolithic Amplifier

0.5-2.5 GHz

Product Features

- 2.8V & 5V operation
- Micro-miniature size .120"X.120"
- Internal DC blocking at RF input and output
- High directivity, 17 dB typ.
- Low noise figure, 2.9 dB typ.
- Output power, up to +16.2 dBm typ. at 0.5 GHz & 5V
- Excellent repeatability
- Low cost
- Aqueous washable



MNA-5B+

CASE STYLE: DQ849
Price: Contact Sales Dept.

+RoHS Compliant

The +Suffix identifies RoHS Compliance. See our web site for RoHS Compliance methodologies and qualifications

Typical Applications

- Buffer amplifier
- Cellular
- PCN
- Communications satellite
- Defense

General Description

MNA-5B+ is a wideband amplifier offering high dynamic range. It has repeatable performance from lot to lot. It is enclosed in a 3x3 mm MCLP plastic package. MNA-5B+ is fabricated using GaAs MESFET technology. Expected MTBF at 85°C case temperature is 45,000 years at 2.8V; 7,000 years at 5V.

Function	Pin Number	Description	
RF IN	2	RF input pin	
RF-OUT	5	RF output pin	
DC	7, with 1000 pF bypass to ground; connect pin 8 via 33 ohms to pin 7 externally	Bias pins	
GND	3,4 and paddle in center of bottom	Connections to ground	
OPTIONAL	1,6	No internal connection; recommended use: per PCB Layout PL-078	

Notes

- A. Performance and quality attributes and conditions not expressly stated in this specification document are intended to be excluded and do not form a part of this specification document.
 B. Electrical specifications and performance data contained in this specification document are based on Mini-Circuit's applicable established test performance criteria and measurement instructions.
 C. The parts covered by this specification document are subject to Mini-Circuits standard limited warranty and terms and conditions (collectively, "Standard Terms"); Purchasers of this part are entitled to the rights and benefits contained therein. For a full statement of the Standard Terms and the exclusive rights and remedies thereunder, please visit Mini-Circuits' website at www.minicircuits.com/MCLStore/terms.jsp



Electrical Specifications at 25°C

Parameter	Min.	Typ.		Max.	Units	
Frequency Range	0.5			2.5	GHz	
at DC Volts	5.0	5.0	2.8	5.0	V	
Gain	f=0.5 GHz	—	18.3	17.2	—	dB
	f=1.0 GHz	—	22.1	20.3	—	
	f=1.5 GHz	—	23.1	20.8	—	
	f=2.0 GHz	21.5	23.0	20.8	—	
	f=2.5 GHz	—	21.7	19.9	—	
Input Return Loss			14	14		dB
Output Return Loss			12.5	10		dB
Output Power @ 1 dB compression	f=0.5 GHz		16.2	13.2		dBm
	f=2.5GHz		13.9	10.7		
Output IP3	f=1 GHz		28	25		dBm
	f=2 GHz		26	23		
Noise Figure			2.9			dB
Directivity (Isolation - Gain)			17			
DC Current	52	61	53	66		mA
Thermal Resistance, junction-to-case			78			°C/W

Absolute Maximum Ratings

Parameter	Ratings
Operating Temperature	-40°C to 85°C
Storage Temperature	-55°C to 100°C
DC Voltage	7V at pin 7 10V at pins 2 & 5
Power Dissipation	500mW
Input Power	10dBm (continuous operation)
	26dBm (5 minutes max)

Note: Permanent damage may occur if any of these limits are exceeded.
These ratings are not intended for continuous normal operation.

Notes

- A. Performance and quality attributes and conditions not expressly stated in this specification document are intended to be excluded and do not form a part of this specification document.
 B. Electrical specifications and performance data contained in this specification document are based on Mini-Circuit's applicable established test performance criteria and measurement instructions.
 C. The parts covered by this specification document are subject to Mini-Circuits standard limited warranty and terms and conditions (collectively, "Standard Terms"); Purchasers of this part are entitled to the rights and benefits contained therein. For a full statement of the Standard Terms and the exclusive rights and remedies thereunder, please visit Mini-Circuits' website at www.minicircuits.com/MCLStore/terms.jsp



Product Marking



← Family marking

Additional Detailed Technical Information

Additional information is available on our web site. To access this information enter the model number on our web site home page.

Performance data, graphs, s-parameter data set (.zip file)

Case Style: DQ849

MNA-5B+: Plastic package, exposed paddle, lead finish: tin-silver over nickel

Tape & Reel: F104

Standard quantities available on reel: 7" reels with 20, 50, 100, 200, 500, 1K, or 2K devices.

Suggested Layout for PCB Design: PL-078

Evaluation Board: TB-186+

Environmental Ratings: ENV08T1

Recommended Application Circuit

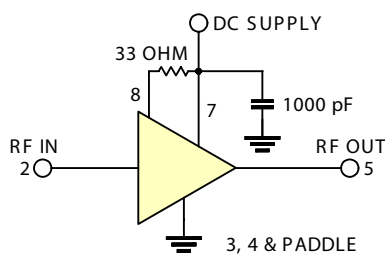

Notes

- Performance and quality attributes and conditions not expressly stated in this specification document are intended to be excluded and do not form a part of this specification document.
- Electrical specifications and performance data contained in this specification document are based on Mini-Circuit's applicable established test performance criteria and measurement instructions.
- The parts covered by this specification document are subject to Mini-Circuits standard limited warranty and terms and conditions (collectively, "Standard Terms"); Purchasers of this part are entitled to the rights and benefits contained therein. For a full statement of the Standard Terms and the exclusive rights and remedies thereunder, please visit Mini-Circuits' website at www.minicircuits.com/MCLStore/terms.jsp



ESD Rating

Human Body Model (HBM): Class 1A (250v to < 500v) in accordance with ANSI/ESD STM 5.1 - 2001

Charged Device Model (CDM): Class III (500 to 1000v) in accordance with JESD22-C101A

MSL Rating

Moisture Sensitivity: MSL1 in accordance with IPC/JEDEC J-STD-020C

No.	Test Required	Condition	Standard	Quantity
1	Visual Inspection	Low Power Microscope Magnification 40x	MIP-IN-0003 (MCT spec)	45 units
2	Electrical Test	Room Temperature	SCD (MCL spec)	45 units
3	SAM Analysis	Less than 10% growth in term of delamination	J-Std-020C (Jedec Standard)	45 units
4	Moisture Sensitivity Level 1	Bake at 125°C for 24 hours Soak at 85°C/85%RH for 168 hours Reflow 3 cycles at 260°C peak	J-Std-020C (Jedec Standard)	45 units

MSL Test Flow Chart

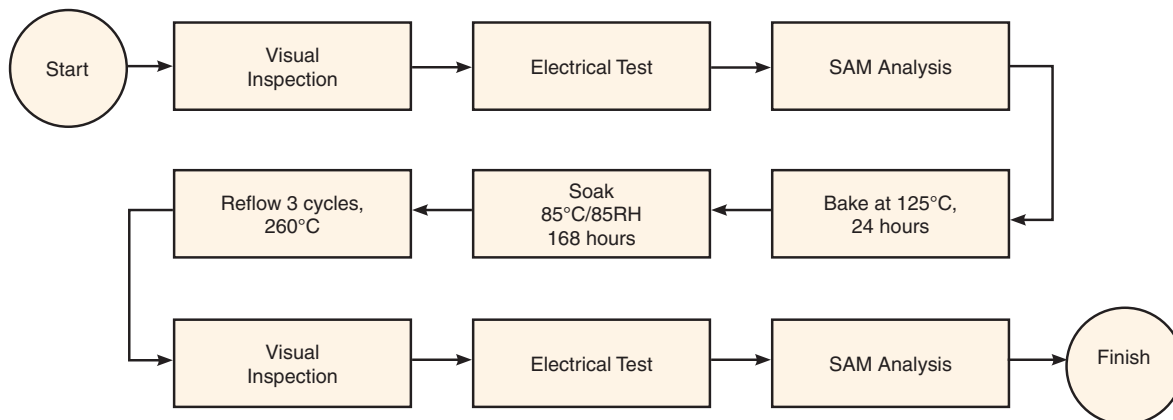

Notes

- A. Performance and quality attributes and conditions not expressly stated in this specification document are intended to be excluded and do not form a part of this specification document.
- B. Electrical specifications and performance data contained in this specification document are based on Mini-Circuit's applicable established test performance criteria and measurement instructions.
- C. The parts covered by this specification document are subject to Mini-Circuits standard limited warranty and terms and conditions (collectively, "Standard Terms"); Purchasers of this part are entitled to the rights and benefits contained therein. For a full statement of the Standard Terms and the exclusive rights and remedies thereunder, please visit Mini-Circuits' website at www.minicircuits.com/MCLStore/terms.jsp