



MMIC SURFACE MOUNT Amplifier

PGA-32-75+

75Ω 5 to 300 MHz

THE BIG DEAL

- High IP3, +45.5 dBm Typ. at 100 MHz
- Gain, 15.6 dB Typ. at 100 MHz
- High Pout, P1dB +23.7 dBm Typ. at 100 MHz
- Low Noise Figure, 2.9 dB Typ. at 100 MHz

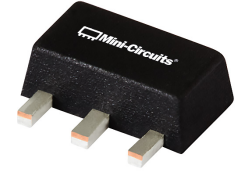

Generic photo used for illustration purposes only

CASE STYLE: DF782

+RoHS Compliant

The +Suffix identifies RoHS Compliance.
See our website for methodologies and qualifications

APPLICATIONS

- CATV, DOCSIS 3.1/WLAN

PRODUCT OVERVIEW

PGA-32-75+ (RoHS compliant) is an advanced wideband Amplifier fabricated using E-PHEMT technology and offers extremely high dynamic range over a broad frequency range with low Noise Figure and flat Gain. It has repeatable performance from lot to lot and is enclosed in a SOT-89 package for very good thermal performance.

KEY FEATURES

Feature	Advantages
Broadband: 5 to 300 MHz	5 to 300 MHz bandwidth covers primary CATV applications such as DOCSIS 3.1.
High IP3 Versus DC Power Consumption: +45.5 dBm Typ. at 100 MHz	The PGA-32-75+ matches industry leading IP3 performance relative to device size and power consumption. The combination of the design and E-PHEMPT structure provides enhanced linearity over a broad frequency range as evident in the IP3 being typically 15-20 dB above the P1dB point. This feature makes this Amplifier ideal for use in CATV applications.
High IP2, +58.1 dBm Typ. at 100 MHz	Suppresses second order product on wideband applications such as CATV.
Low Noise Figure, 2.9 dB Typ. at 100 MHz	Low Noise Figure performance in combination with the high output IP3 results in high dynamic range.

REV. B
ECO-015393
PGA-32-75+
MCL NY
240807



ELECTRICAL SPECIFICATIONS AT +25°C, 75Ω, UNLESS NOTED OTHERWISE

Parameter	Condition (MHz)	TB-966+				TB-916+		Units
		VDD=+9V ¹		VDD=+5V ¹		VDD=+9V ²	VDD=+5V ²	
		Min.	Typ.	Max.	Typ.	Typ.	Typ.	
Frequency Range		5		300	5-300	5-150	5-150	MHz
Gain	5		15.8		15.3	15.8	15.3	dB
	10		15.7		15.2	15.8	15.2	
	100	14.0	15.6	17.2	15.1	15.7	15.2	
	150		15.6		15.1	15.6	15.1	
	200		15.5		15.0	—	—	
	300		15.4		14.9	—	—	
Gain Flatness	5-150		—		—	±0.1	±0.1	dB
	5-300		±0.2		±0.2	—	—	
Input Return Loss	5		13.9		13.4	20.3	18.9	dB
	10		18.2		17.1	19.8	17.5	
	100		22.4		19.8	20.6	18.4	
	150		22.6		19.7	20.7	18.5	
	200		22.4		19.5	—	—	
	300		21.6		18.8	—	—	
Output Return Loss	5		19.8		19.1	19.3	20.0	dB
	10		25.2		23.9	22.5	21.7	
	100		28.4		25.9	23.5	22.0	
	150		26.0		23.8	22.7	21.2	
	200		24.0		21.8	—	—	
	300		18.9		17.4	—	—	
Reversed Isolation	100		20.6		20.5	20.6	20.4	dB
Output Power at 1 dB Compression	5		+20.4 (+69.1)		+19.0 (+67.8)	+23.2 (72)	+18.5 (67.2)	dBm (dBmV)
	10		+21.7 (+70.4)		+18.6 (+67.3)	+23.5 (72.2)	+18.7 (67.4)	
	100		+23.7 (+72.5)		+18.7 (+67.4)	+23.5 (72.3)	+18.5 (67.3)	
	150		+23.7 (+72.4)		+18.6 (+67.3)	+23.6 (72.3)	+18.5 (67.2)	
	200		+23.7 (+72.4)		+18.5 (+67.3)	—	—	
	300		+23.6 (+72.4)		+18.3 (+67.1)	—	—	
Output Third-Order Intercept Point	5		+43.2		+36.8	+44.5	+37.6	dBm
	10		+43.9		+37.3	+44.7	+38.7	
	100		+43.3		+39.1	+45.5	+39.9	
	150		+43.7		+39.1	+45.9	+39.7	
	200		+43.8		+39.1	—	—	
	300		+43.8		+37.7	—	—	
Output Second-Order Intercept Point	5		+57.3		+43.1	+59.6	+45.2	dBm
	10		+58.1		+43.2	+59.1	+44.3	
	100		+57.2		+44.4	+58.1	+44.8	
	150		+56.3		+44.1	+57.0	+44.2	
	200		+55.7		+44.2	—	—	
	300		+56.1		+45.6	—	—	
Noise Figure	5		—		—	—	—	dB
	10		3.8		3.4	3.8	3.4	
	100		2.9		2.7	2.9	2.8	
	150		2.8		2.7	2.8	2.7	
	200		2.9		2.7	—	—	
	300		2.9		2.8	—	—	
Operating Voltage (VDD)			9		5	9	5	V
Operating Current (IDD)			110	140	54	110	55	mA
Current Variation Vs. Temperature ⁴			-2.2		6.5	-2.2	6.5	µA/°C
Current Variation Vs. Voltage ^{5,6}			0.014		0.013	0.014	0.013	mA/mV
Thermal Resistance, Junction-to-Ground Lead (θJC)			30		30	30	30	°C/W

1. Measured on Mini-Circuits Characterization Board TB-966+. See Characterization Test and Application Circuit (TB-966+) (Fig.1A)

2. Measured on Mini-Circuits Characterization Board TB-916+. See Characterization Test and Application Circuit (TB-916+) (Fig.1B)

3. OIP2 measured at sum frequencies of the two Tones (Frequency Measured = F1 + F2).

4. Device Current Variation Vs. Temperature = (Current in mA at 85°C - Current in mA at -45°C) / 130°C

5. Device Current Variation Vs. Voltage = (Current in mA at +9.5V - Current in mA at +8.5V) / ((+9.5V-8.5V)*1000mA/mV)

6. Device Current Variation Vs. Voltage = (Current in mA at +5.25V - Current in mA at +4.75V) / ((+5.25V-4.75V)*1000mA/mV)



ABSOLUTE MAXIMUM RATINGS⁵

Parameter	Ratings
Operating Temperature (ground lead)	-40°C to +85°C
Storage Temperature	-65°C to +150°C
Power Dissipation	2.2 W
Input Power (CW)	+23 dBm (5 minutes max) +24 dBm (continuous)
DC Voltage on Pin 3	+11 V

5. Permanent damage may occur if any of these limits are exceeded. Electrical maximum ratings are not intended for continuous normal operation.

SIMPLIFIED SCHEMATIC AND PAD DESCRIPTION

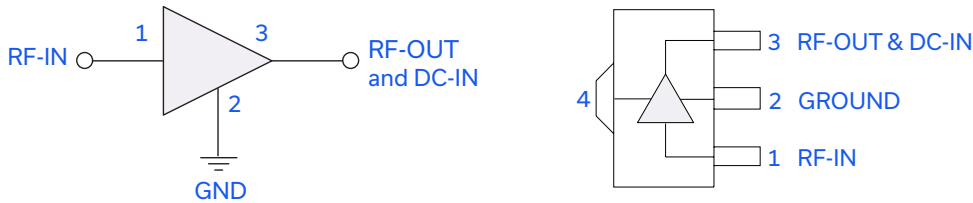

Function	Pin Number	Description
RF-IN	1	RF Input pin. This pin requires the use of an external DC blocking capacitor chosen for the frequency of operation. See Figure 1A & 1B
RF-OUT and DC-IN	3	RF Output and Bias pin. DC voltage is present on this pin; therefore a DC blocking capacitor is necessary for proper operation. An RF choke is needed to feed DC bias without loss of RF signal due to the bias connection. See Figure 1A & 1B
GND	2,4	Connections to ground. Use via holes as shown in "Suggested Layout for PCB Design" to reduce ground path inductance for best performance.

CHARACTERIZATION TEST AND APPLICATION CIRCUIT (TB-966+)

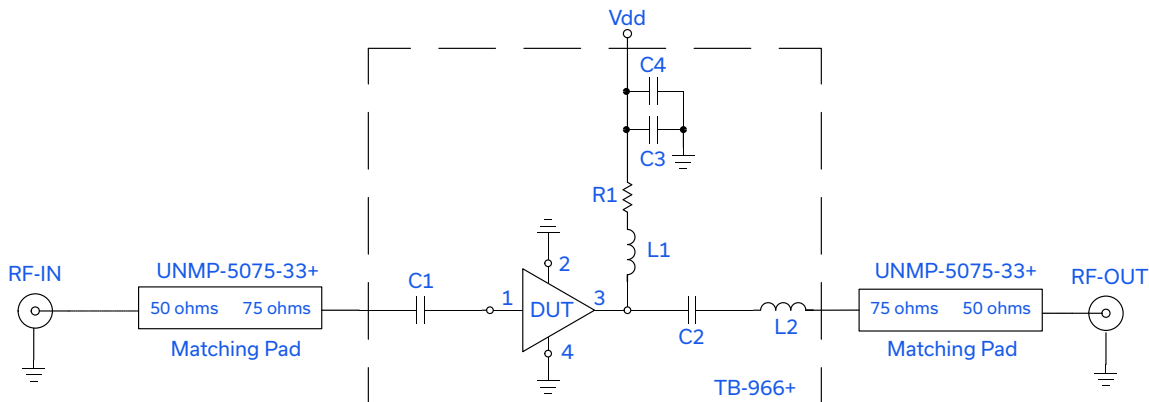

Fig 1A. Characterization Test and Application Circuit (DUT soldered on TB-966+). Gain, Return Loss, Output Power at 1dB Compression (P1dB), Output IP3 (OIP3), Output IP2 (OIP2) and Noise Figure measured using Agilent's N5242A PNA-X Microwave Network Analyzer & E5071C ENA Series Network Analyzer.

Conditions:

1. Gain and Return Loss: $P_{IN} = -25\text{dBm}$
2. Output IP3 (OIP3): Two Tones, spaced 1 MHz apart, +5dBm/Tone at output.
3. Output IP2 (OIP2): Two Tones, spaced 1 MHz apart, +5dBm/Tone at output.

COMPONENT	P/N	VALUE	SIZE
DUT	PGA-32-75+	—	SOT-89
C1,C4	GRM155R71C104KA88D	0.1uF	0402
C2	GRM155R71E103KA01D	0.01uF	0402
C3	GRM1555C1H102JA01D	0.001uF	0402
L1	LQH32MN6R8K23L	6800nH	1210
L2	LQW15AN12NH00D	12nH	0402
R1	RK73H1JTTD4R99F	4.99 Ohm	0603



CHARACTERIZATION TEST AND APPLICATION CIRCUIT (TB-916+)

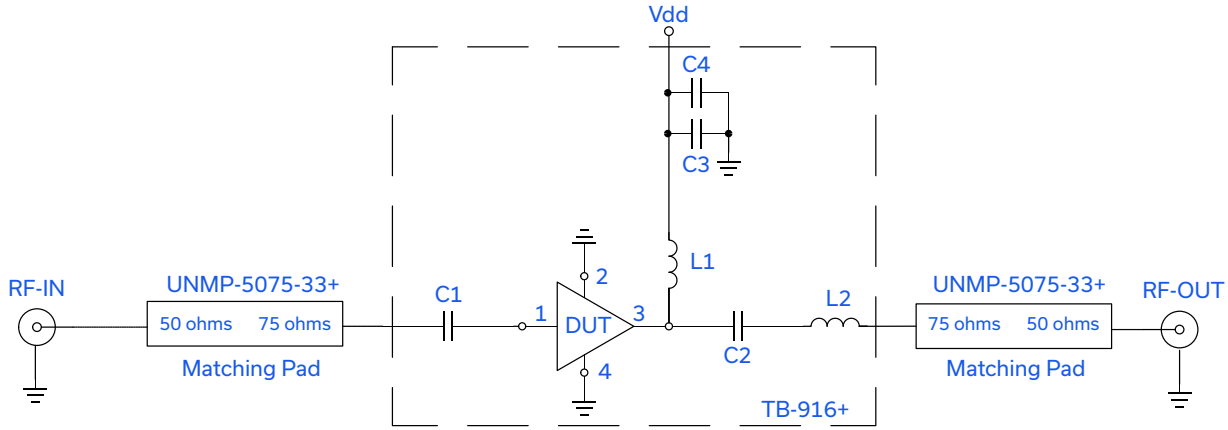

Fig 1B. Characterization Test and Application Circuit (DUT soldered on TB-916+). Gain, Return Loss, Output Power at 1dB Compression (P1dB), Output IP3 (OIP3), Output IP2 (OIP2) and Noise Figure measured using Agilent's N5242A PNA-X Microwave Network Analyzer & E5071C ENA Series Network Analyzer.

Conditions:

1. Gain and Return Loss: $P_{IN} = -25\text{dBm}$
2. Output IP3 (OIP3): Two Tones, spaced 1 MHz apart, +5 dBm/Tone at output.
3. Output IP2 (OIP2): Two Tones, spaced 1 MHz apart, +5 dBm/Tone at output.

COMPONENT	SUPPLIER P/N	VALUE	SIZE
DUT	PGA-32-75+	—	SOT-89
C1	GRM32ER7YA106KA12L	10uF	1210
C2	GRM155R71E103KA01D	0.01uF	0402
C3	GRM1555C1H102JA01D	0.001uF	0402
C4	GRM155R71C104KA88D	0.1uF	0402
L1	1008CS-682XJLC	6.8uH	1008
L2	LQW15AN12NH00D	12nH	0402

PRODUCT MARKING

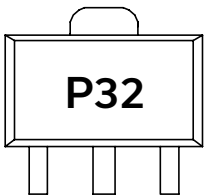

Marking may contain other features or characters for internal lot control



ADDITIONAL DETAILED TECHNICAL INFORMATION IS AVAILABLE ON OUR DASHBOARD. [CLICK HERE](#)

Performance Data	Data Table Swept Graphs S-Parameter (S2P Files) Data Set (.zip file)
5-200 MHz Operation	See Application Note (AN-060-087)
Case Style	DF782 (SOT 89) Plastic package, exposed paddle lead finish: Matte-Tin
Tape & Reel Standard quantities available on reel	F55 7" reels with 20, 50, 100, 200, 500 or 1K devices
Suggested Layout for PCB Design	PL-521
Evaluation Board	TB-966+ (5-300 MHz) & TB-916+ (5-150 MHz)
Environmental Ratings	ENV08T1

ESD RATING

Human Body Model (HBM): Class 1A (+250V to < +500V) in accordance with ANSI/ESD STM 5.1 - 2001

Machine Model (MM): Class M1 (+25V) in accordance with ANSI/ESD STM5.2-1999

MSL RATING

Moisture Sensitivity: MSL1 in accordance with IPC/JEDEC J-STD-020D

NOTES

- A. Performance and quality attributes and conditions not expressly stated in this specification document are intended to be excluded and do not form a part of this specification document.
- B. Electrical specifications and performance data contained in this specification document are based on Mini-Circuit's applicable established test performance criteria and measurement instructions.
- C. The parts covered by this specification document are subject to Mini-Circuits standard limited warranty and terms and conditions (collectively, "Standard Terms"); Purchasers of this part are entitled to the rights and benefits contained therein. For a full statement of the standard. Terms and the exclusive rights and remedies thereunder, please visit Mini-Circuits' website at www.minicircuits.com/MCLStore/terms.jsp