



LOW NOISE, HIGH IP3

Monolithic Amplifier

PSA-5454+

50Ω 0.05 to 4 GHz

THE BIG DEAL

- Ultra Low Noise Figure, 0.8 dB typ. at 1 GHz
- High IP3, +25 dBm typ. 1 GHz
- Single Positive Supply Voltage, +5V, Id=20mA
- Gain, 18 dB typ. at 1 GHz
- Output Power, up to +14 dBm typ.
- Micro-miniature size SOT-363 package
- Aqueous washable

APPLICATIONS

- Cellular
- ISM
- GSM
- WCDMA
- LTE
- WiMAX
- WLAN
- UNII and HIPERLAN

PRODUCT OVERVIEW

Mini-Circuits PSA-5454+ is a E-PHEMT* based Ultra-Low Noise MMIC Amplifier operating from 50 MHz to 4 GHz with a unique combination of low noise and high IP3 making this amplifier ideal for sensitive receiver applications. This design operates on a single +5V supply at only 20 mA and is internally matched to 50 ohms.



Generic photo used for illustration purposes only

CASE STYLE: CA1389

+RoHS Compliant

The +Suffix identifies RoHS Compliance.
See our website for methodologies and qualifications

KEY FEATURES

Feature	Advantages
Ultra Low Noise, 0.8 dB typ.	Outstanding Noise Figure, measured in a 50 Ohm environment without any external matching
High IP3, +25 dBm typ.	Combining Low Noise and High IP3 makes this MMIC amplifier ideal for Low Noise Receiver Front End (RFE) because it gives the user advantages at both ends of the dynamic range: sensitivity & two-tone spur-free dynamic range
Low Current, 20 mA	At only 20 mA, the PSA-5454+ is ideal for remote applications with limited available power or densely packed applications where thermal management is critical.
Broad Band	Operating over a broadband the PSA-5454+ covers the primary wireless communications bands: Cellular, PCS, LTE, WiMAX
Internally Matched	No external matching elements required to achieve the advertised noise and output power over the full band
SOT-363 Package	Small size, industry standard package
Max Input Power, +15 dBm	Ruggedized design operates up to input powers of +15 dBm without the need of an external limiter
High Reliability	Low, small signal operating current of 30 mA nominal maintains junction temperatures typically below 105°C at 85°C ground lead temperature

* Enhancement mode pseudomorphic High Electron Mobility Transistor.

REV. C
ECO-011279
PSA-5454+
MCL NY
240927





LOW NOISE, HIGH IP3

Monolithic Amplifier

PSA-5454+

50Ω 0.05 to 4 GHz

ELECTRICAL SPECIFICATIONS¹ AT 25°C, Z₀=50Ω, (REFER TO CHARACTERIZATION CIRCUIT, FIG. 1)

Parameter	Condition (GHz)	Min.	Typ.	Max.	Units
Frequency Range		0.05		4.0	GHz
DC Voltage (V _d)			+5.0		V
DC Current (I _d) ²		12	20	40	mA
DC Current (I _{Rbias})			0.6		mA
Noise Figure	0.05		2.6	—	dB
	0.5		0.8	—	
	1.0		0.8	—	
	2.0		1.1	1.3	
	3.0		1.4	—	
	4.0		1.7	—	
Gain	0.05	—	21.1	—	dB
	0.5	—	21.6	—	
	1.0	—	18.3	—	
	2.0	12.2	13.6	14.9	
	3.0	—	10.9	—	
	4.0	—	9.3	—	
Input Return Loss	0.05-0.5		8.0		dB
	0.5-4.0		6.0		
Output Return Loss	0.05-0.5		7.0		dB
	0.5-4.0		15.0		
Output IP3	0.05		+21.2		dBm
	0.5		+24.7		
	1.0		+25.3		
	2.0		+26.3		
	3.0		+26.2		
	4.0		+26.0		
Output Power @ 1 dB compression (P1dB) ³	0.05		+6.6		dBm
	0.5		+14.6		
	1.0		+15.0		
	2.0		+14.0		
	3.0		+14.0		
	4.0		+14.5		
DC Current Variation vs. Temperature ⁴			-0.08		mA/°C
Thermal Resistance			165		°C/W

1. Measured on Mini-Circuits Characterization test board TB-533+. See Characterization Test Circuit (Fig. 1)
2. Specified DC current consumption is under small signal conditions. Current will increase with input RF Power. To maintain maximum current consumption, external DC current limiting circuits are required on V_d line.
3. Specified with external current limiting of 30 mA. Capable of higher P1dB at higher currents (see Fig. 2)
4. Current at 85°C - Current at -45°C/130





LOW NOISE, HIGH IP3

Monolithic Amplifier

PSA-5454+

50Ω 0.05 to 4 GHz

ABSOLUTE MAXIMUM RATINGS⁴

Parameter	Ratings
Operating Temperature ⁵	-40°C to +85°C
Storage Temperature	-65°C to +150°C
Channel Temperature	+150°C
DC Voltage (Pin 6)	+6 V
Power Dissipation	390 mW
DC Current (Pin 6)	60 mA
Bias Current (Pin 4)	10 mA
Input Power (CW) ⁷	+15 dBm

4. Permanent damage may occur if any of these limits are exceeded. These maximum ratings are not intended for continuous normal operation.

5. Defined with reference to ground pad temperature.

7. Maximum input power is specified based upon external Vd current limiting of 40 mA. Maximum input power will degrade without external current limiting.

SIMPLIFIED SCHEMATIC AND PIN DESCRIPTION

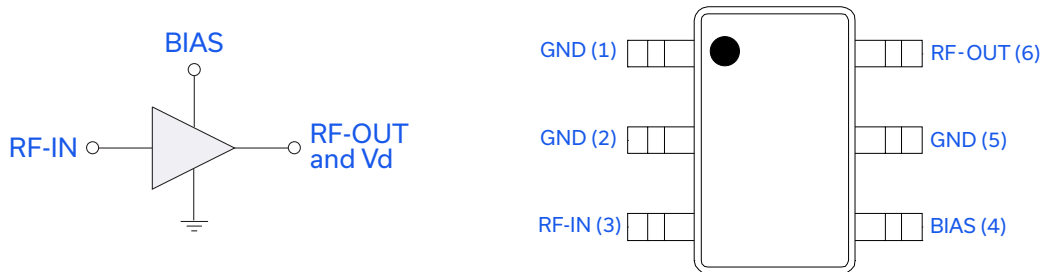

Function	Pin Number	Description (See Application Circuit, Fig. 3)
RF-IN	3	RF input pin (connect to RF-IN via blocking cap C1 and Pin 4 via L2)
RF-OUT & Vd	6	RF output pin (connected to RF-out via blocking cap C2 and supply voltage Vd via RF Choke L1)
BIAS	4	Connected to Vs via Rbias. (Connect to ground via C4 & R1)
GND	1,2,5	Connections to ground

CHARACTERIZATION TEST CIRCUIT

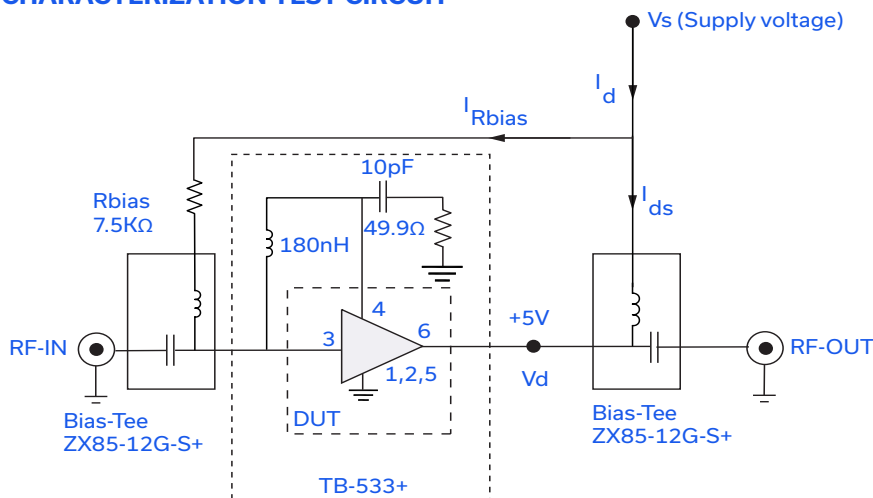

Fig 1. Block Diagram of Test Circuit used for characterization. (DUT soldered on Mini-Circuits Characterization Test Board TB-533+) Gain, Output power at 1dB compression (P1 dB), output IP3 (OIP3) and Noise Figure measured using Agilent's N5242A PNA-X microwave network analyzer.

Conditions:

1. Gain: $P_{IN} = -25\text{dBm}$
2. Output IP3 (OIP3): Two tones, spaced 1 MHz apart, 0 dBm/tone at output.
3. V_s adjusted for 5V at device (V_d), compensating loss of bias tee.





LOW NOISE, HIGH IP3

Monolithic Amplifier

PSA-5454+

50Ω 0.05 to 4 GHz

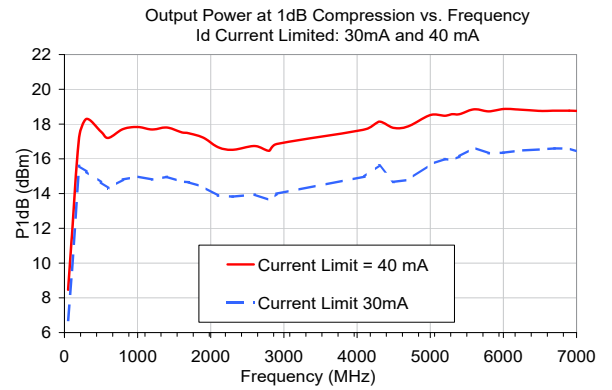
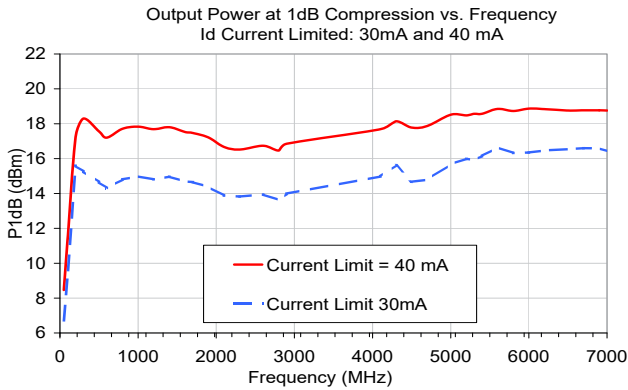

Fig 2. Output Power and Id vs. Input Power and Frequency.

Performance measured on Mini-Circuits Characterization test board TB-533+. See Characterization Test Circuit (Fig. 1) Measurements performed with current (Id) limited as noted.

RECOMMENDED APPLICATION CIRCUIT

(refer to evaluation board for PCB Layout and component values)

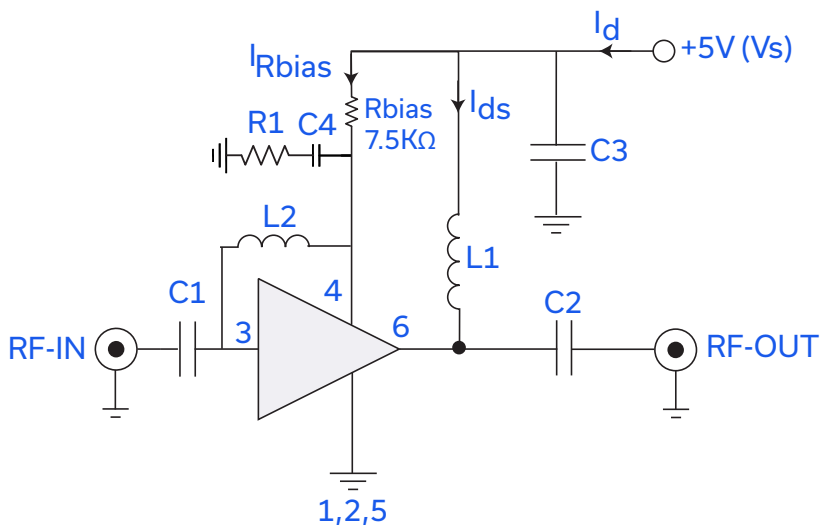

Fig 3. Recommended Application Circuit
Note: Resistance of L1, 0.1-0.2Ω typically





LOW NOISE, HIGH IP3

Monolithic Amplifier

PSA-5454+

Mini-Circuits

50Ω 0.05 to 4 GHz

TYPICAL CURRENT (ID) AS A FUNCTION OF RBIAS (VS = 5V)

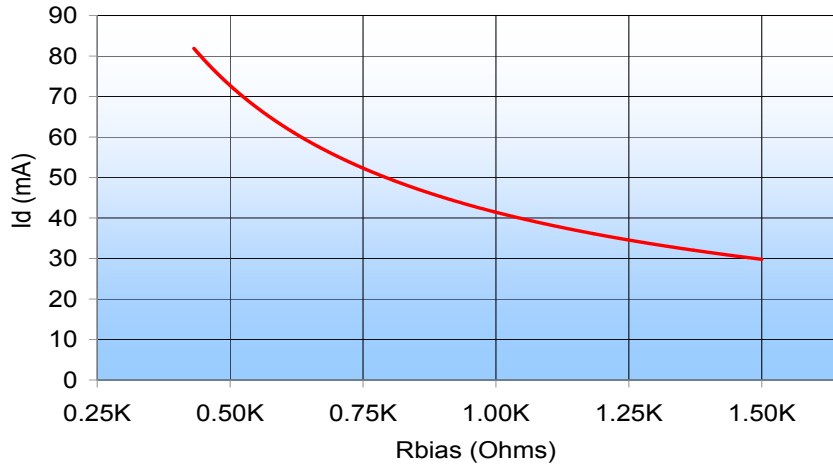
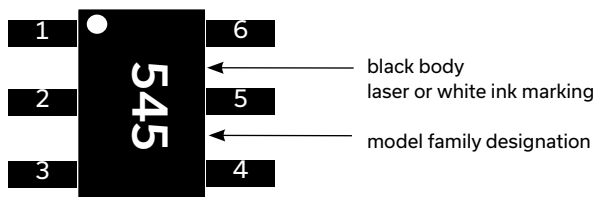

Fig 4. Id varies as a function of Rbias. The Id current range is defined based upon the specific Rbias value noted in the Application Circuit (Fig 3). Rbias may be adjusted to optimize Id for a customers' application. RF performance will vary accordingly.

PRODUCT MARKING



Marking may contain other features or characters for internal lot control

Mini-Circuits



LOW NOISE, HIGH IP3

Monolithic Amplifier

PSA-5454+

50Ω 0.05 to 4 GHz

ADDITIONAL DETAILED TECHNICAL INFORMATION IS AVAILABLE ON OUR DASHBOARD.

[CLICK HERE](#)

Performance Data	Data Table Swept Graphs S-Parameter (S2P Files) Data Set (.zip file)
Case Style	CA1389 Plastic molded SOT-363 package, lead finish: Matte-Tin
Tape & Reel Standard quantities available on reel	F101 7" reels with 20, 50, 100, 200, 500, 1K, or 2K devices
Suggested Layout for PCB Design	PL-311
Evaluation Board	TB-534-4+
Environmental Ratings	ENV08T2

ESD RATING

Human Body Model (HBM): Class 1A (250 to <500V) in accordance with ANSI/ESD STM 5.1 - 2001

Machine Model (MM): Class M1 (<100V) in accordance with ANSI/ESD STM5.2-1999; passes 40V

MSL RATING

Moisture Sensitivity: MSL1 in accordance with IPC/JEDEC J-STD-020D

MSL TEST FLOW CHART

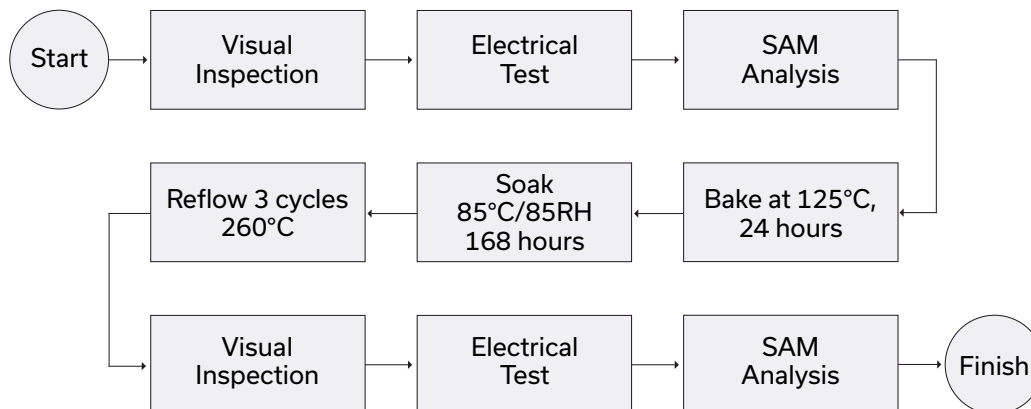

- NOTES**
- A. Performance and quality attributes and conditions not expressly stated in this specification document are intended to be excluded and do not form a part of this specification document.
 - B. Electrical specifications and performance data contained in this specification document are based on Mini-Circuit's applicable established test performance criteria and measurement instructions.
 - C. The parts covered by this specification document are subject to Mini-Circuits standard limited warranty and terms and conditions (collectively, "Standard Terms"); Purchasers of this part are entitled to the rights and benefits contained therein. For a full statement of the standard terms and the exclusive rights and remedies thereunder, please visit Mini-Circuits' website at www.minicircuits.com/terms/viewterm.html

