

# Mini-Circuits® Portable Test Equipment

## Reducing Costs in Automated Test Measurement



# Automated Test Equipment required for Insertion Loss, Return Loss, Gain, P1dB...

- Network Analyzer ~ \$30K - \$40K
- Spectrum Analyzer ~ \$20K - \$30K
- Signal Generator ~ \$10K - \$30K



**\$100K ??**  
Only for a simple measurement ?



# Additional Costs

- Employee Training
- Measurement Software
- Calibration
- Repair

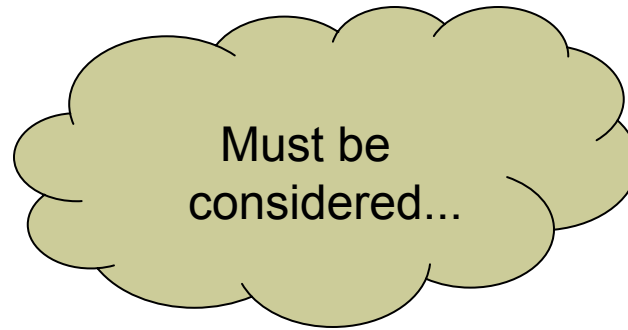

# Test Equipment Selection: Key Considerations

- What kind of measurements do I need to make?
- Which signals am I measuring?
- What is the frequency range?
- What functions & features will I use?
- What is the required accuracy?

## *Similarly:*

- I would like to go from point A to point B:
- Do I really need a car?
- Do I really need an *expensive* car?
- Do I have other alternatives?





# 2-Port DUT (Filter): Insertion Loss & Return Loss

## Test Results Comparison vs. Scalar Network Analyzer

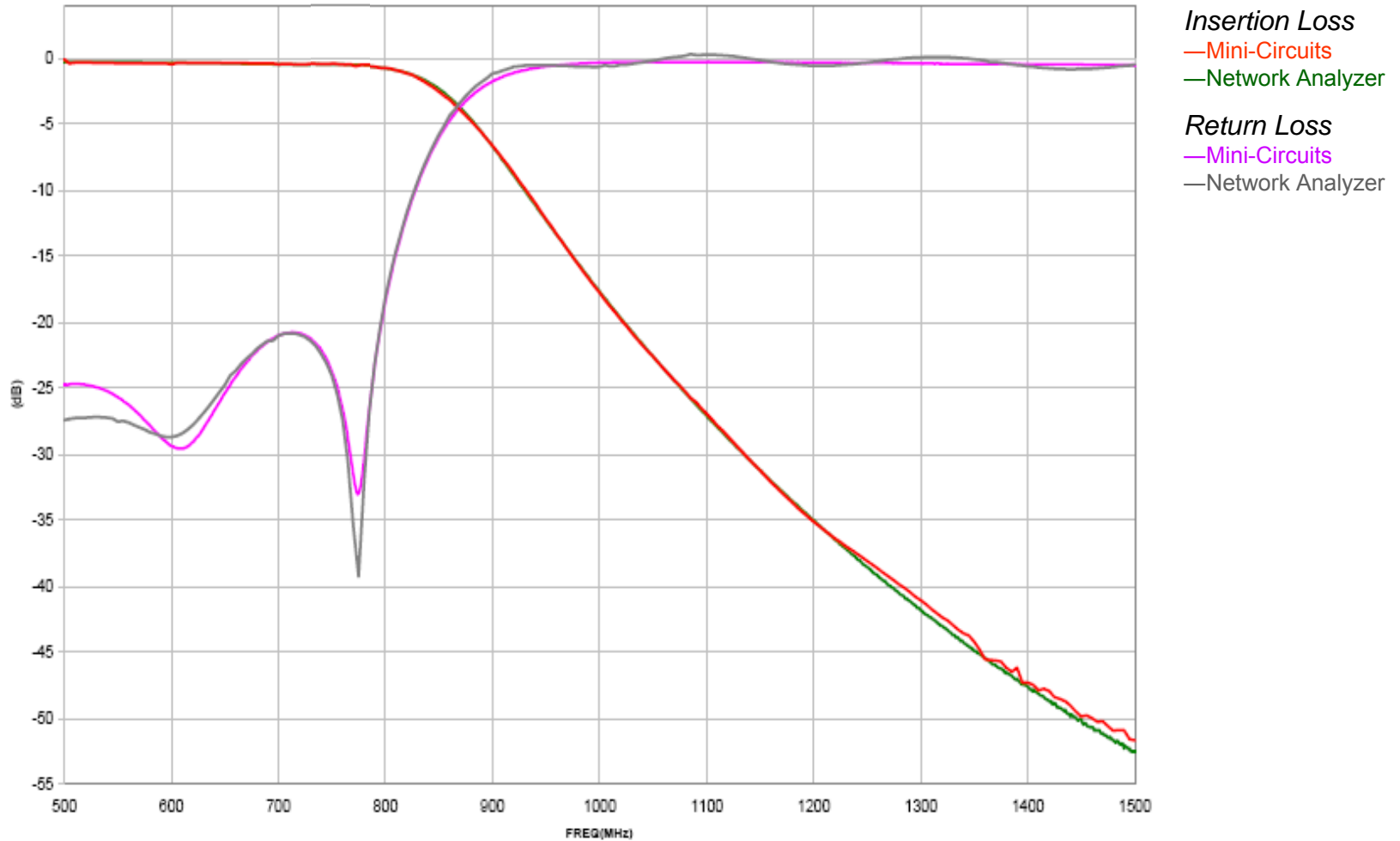

# Display Options: Graph, Text, & Spreadsheet

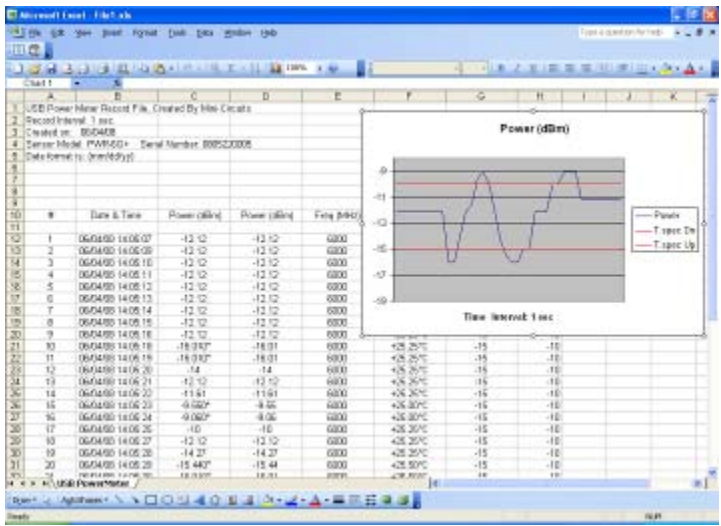

sample1.txt - Notepad

USB Power Meter Record File, Created By Mini-Circuits

Record Interval: 1 sec.  
 Created on: 06/04/08  
 Sensor Model: PWR-6G+ Serial Number: 0805220005  
 Date format is: (mm/dd/yyyy)

Date & Time	Power (dBm)	Freq (MHz)	Device Temp	TSpecdn (dBm)	TSpecup (dBm)
06/04/08 14:05:07	-12.120	6000.00	+25.25°C	-15.000	-10.000
06/04/08 14:05:10	-12.120	6000.00	+25.25°C	-15.000	-10.000
06/04/08 14:05:11	-12.120	6000.00	+25.00°C	-15.000	-10.000
06/04/08 14:05:12	-12.120	6000.00	+25.25°C	-15.000	-10.000
06/04/08 14:05:13	-12.120	6000.00	+25.25°C	-15.000	-10.000
06/04/08 14:05:14	-12.120	6000.00	+25.25°C	-15.000	-10.000
06/04/08 14:05:15	-12.120	6000.00	+25.25°C	-15.000	-10.000
06/04/08 14:05:16	-12.120	6000.00	+25.25°C	-15.000	-10.000
06/04/08 14:05:18	-16.010*	6000.00	+25.25°C	-15.000	-10.000
06/04/08 14:05:20	-14.000	6000.00	+25.25°C	-15.000	-10.000
06/04/08 14:05:21	-12.120	6000.00	+25.25°C	-15.000	-10.000
06/04/08 14:05:22	-11.610	6000.00	+25.25°C	-15.000	-10.000
06/04/08 14:05:23	-9.550*	6000.00	+25.00°C	-15.000	-10.000
06/04/08 14:05:24	-9.060*	6000.00	+25.00°C	-15.000	-10.000
06/04/08 14:05:25	-10.000	6000.00	+25.25°C	-15.000	-10.000
06/04/08 14:05:27	-12.120	6000.00	+25.25°C	-15.000	-10.000
06/04/08 14:05:28	-14.270	6000.00	+25.25°C	-15.000	-10.000
06/04/08 14:05:29	-15.440*	6000.00	+25.50°C	-15.000	-10.000
06/04/08 14:05:30	-16.010*	6000.00	+25.50°C	-15.000	-10.000
06/04/08 14:05:31	-16.010*	6000.00	+25.50°C	-15.000	-10.000
06/04/08 14:05:32	-14.990	6000.00	+25.25°C	-15.000	-10.000
06/04/08 14:05:33	-14.990	6000.00	+25.25°C	-15.000	-10.000
06/04/08 14:05:35	-12.110	6000.00	+25.25°C	-15.000	-10.000

Project: I.LOSS Meas for NLP-2400

Sensor Serial Number: 11009260016

Model Name: NLP-2400  
 Run No.:  
 Application: Insertion Loss 2 Port

**I.LOSS Measurement**

Step 1: Power Reference In  
 Step 2: D.U.T Measurement

Avg: 8

#	Freq (MHz)	Source Pwr (dBm)	PwrRef In (dBm)	Read Pwr (dBm)	Measured I.Loss (dB)	Min (dB)	Max (dB)	Pass/Fail	Safe Att. (dB)
1	2000.000000	0.00	-20.68	-21.07	-0.39	-1.0		Pass	
2	2025.000000	0.00	-20.61	-20.80	-0.19	-1.0		Pass	
3	2050.000000	0.00	-20.72	-20.90	-0.18	-1.0		Pass	
4	2075.000000	0.00	-21.03	-21.22	-0.19	-1.0		Pass	
5	2100.000000	0.00	-20.64	-20.78	-0.14	-1.0		Pass	
6	2125.000000	0.00	-20.48	-20.66	-0.18	-1.0		Pass	
7	2150.000000	0.00	-20.87	-21.10	-0.23	-1.0		Pass	
8	2175.000000	0.00	-20.49	-20.72	-0.23	-1.0		Pass	
9	2200.000000	0.00	-20.78	-21.05	-0.27	-1.0		Pass	
10	2225.000000	0.00	-20.87	-21.23	-0.36	-20.0		Pass	
11	2250.000000	0.00	-20.81	-21.18	-0.37	-20.0		Pass	
12	2275.000000	0.00	-20.40	-20.77	-0.37	-20.0		Pass	
13	2300.000000	0.00	-20.80	-21.37	-0.57	-20.0		Pass	
14	2325.000000	0.00	-20.90	-21.73	-0.83	-20.0		Pass	
15	2350.000000	0.00	-20.72	-21.58	-0.86	-20.0		Pass	
16	2375.000000	0.00	-20.44	-21.52	-1.08	-20.0		Pass	

D.U.T. No: 1 DUT Serial No:

Run Stop Continuous Mode Display On-Line Graph

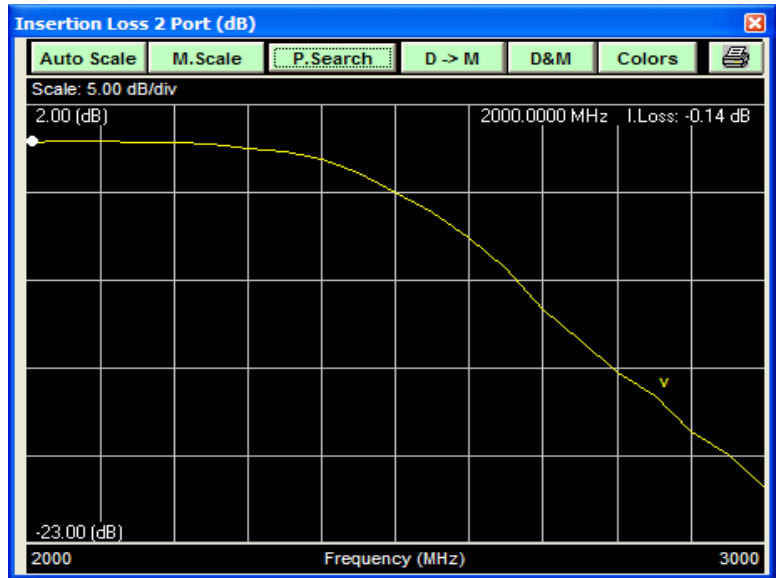

# 2-Port DUT (Amplifier): Gain & Compression

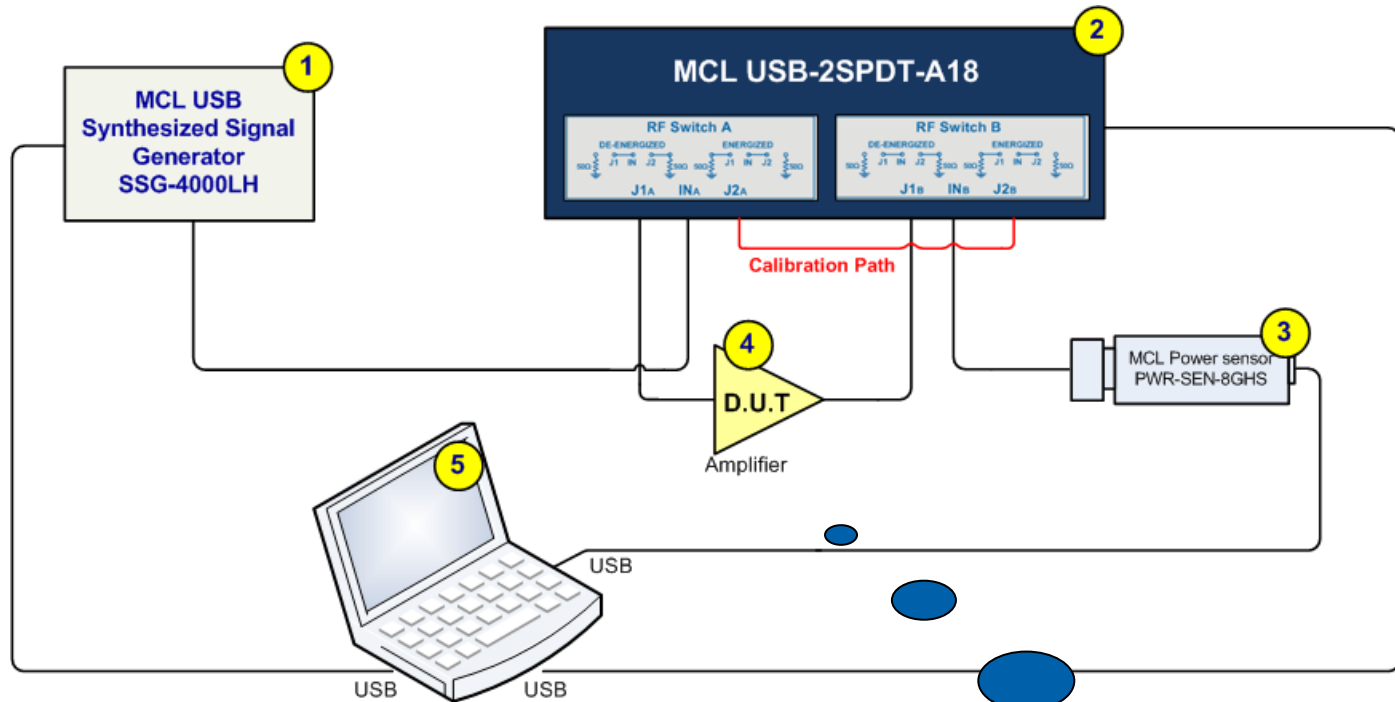

- MCL USB Signal Generator ~ \$2K
- MCL USB Switch 2SPDT-A18 ~ \$700
- MCL USB Power Meter ~ \$700

**Including built-in measurement software**

- DUT – 2 Port Device such as Amplifier, Cable, Attenuator, Filter etc

**Total setup  
less than \$3.5K**

# 2-Port DUT (Amplifier): Gain & Compression

## Test Results Comparison vs. Scalar Network Analyzer

FREQ. (MHz)	GAIN MCL (dB)	GAIN Network (dB)	DELTA* GAIN
250	12.65	12.83	0.18
300	12.52	12.8	0.28
400	12.75	12.79	0.04
500	12.59	12.76	0.17
600	12.57	12.72	0.15
700	12.69	12.67	0.02
800	12.37	12.63	0.26
900	12.53	12.54	0.01
1000	12.48	12.38	0.1
1100	12.47	12.35	0.12
1200	12.44	12.34	0.1
1300	12.63	12.27	0.36
1400	12.34	12.29	0.05
1500	12.23	12.28	0.05
1600	12.27	12.23	0.04
1700	12.15	12.18	0.03
1800	12.16	12.07	0.09
1900	12.16	11.96	0.2
2000	12.05	11.93	0.12
2100	12.06	11.85	0.21
2200	11.99	11.76	0.23
2300	11.85	11.72	0.13
2400	11.7	11.7	0
2500	11.71	11.66	0.05
2600	11.72	11.71	0.01
2700	11.76	11.68	0.08
2800	11.73	11.62	0.11
2900	11.64	11.57	0.07
3000	11.66	11.53	0.13
3100	11.56	11.44	0.12
3200	11.5	11.37	0.13
3300	11.25	11.34	0.09
3400	11.38	11.33	0.05
3500	11.52	11.31	0.21
3600	11.3	11.32	0.02
3700	11.47	11.28	0.19
3800	11.34	11.23	0.11
3900	11.24	11.22	0.02
4000	11.15	11.2	0.05

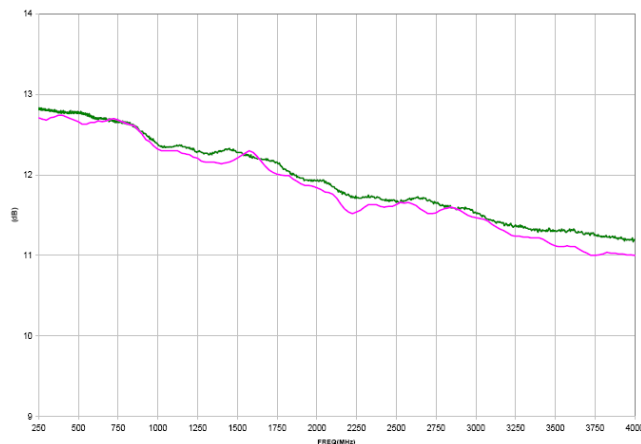

Gain  
 —Mini-Circuits  
 —Network Analyzer

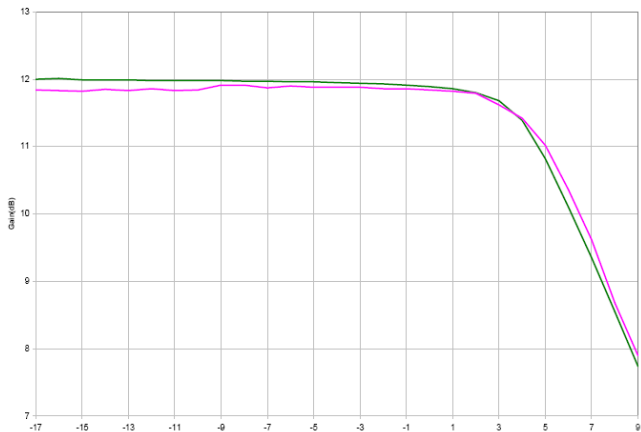

1dB Compression  
 —Mini-Circuits  
 —Network Analyzer

# 3-Port DUT (Mixer): Conversion Loss, Isolation & Compression

Total setup less than \$6K

4 different measurements

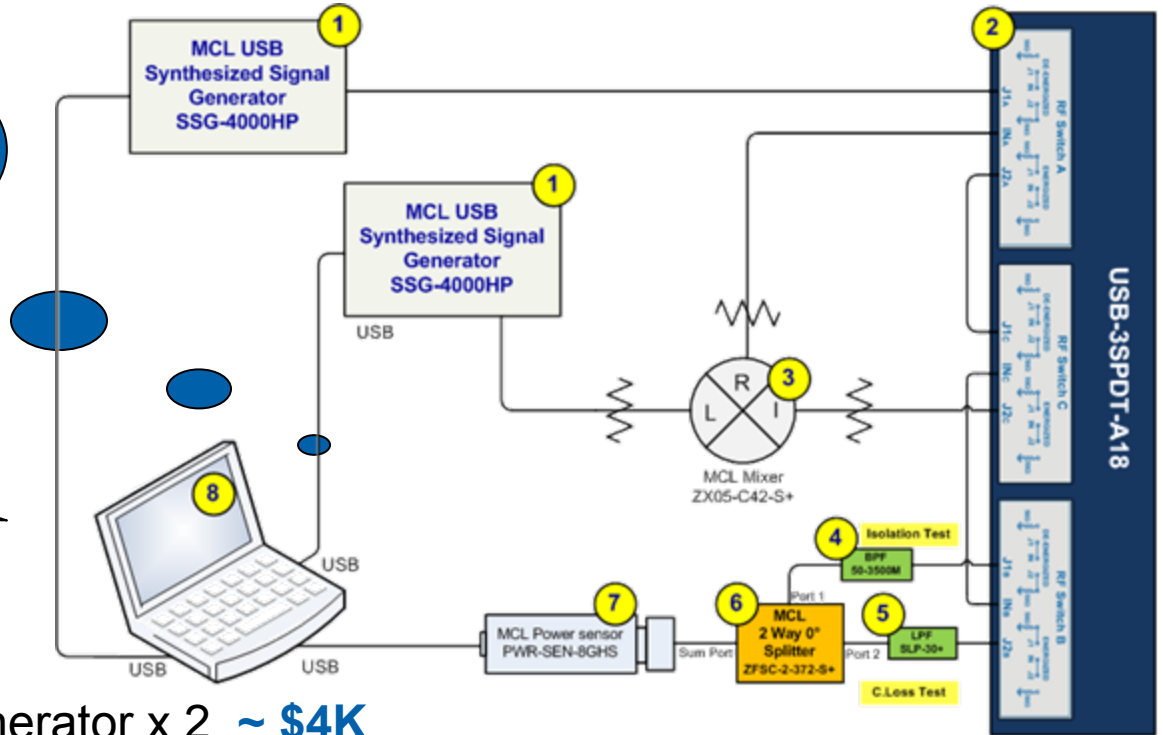

- MCL USB Signal Generator x 2 ~ \$4K
- MCL USB Switch 3SPDT-A18 ~ \$1K
- MCL USB Power Meter ~ \$700

Custom measurement software available for purchase

- DUT– 3 Port Device such as Mixer, Splitter, Coupler etc

Mixer's Conditions		
RF (MHz)	LO (MHz)	IF (MHz)
2000	2030	30
2200	2230	30
3200	3230	30
3500	3530	30

**C.Loss & 1dB Meas.**  
 Switch A is set to J1-IN  
 Switch B is set to J2-IN  
 Switch C is set to J2-IN

**Isolation Meas.**  
**L-R:**  
 Switch A is set to J2-IN  
 Switch B is set to J1-IN  
 Switch C is set to J1-IN  
**L-L:**  
 Switch A is set to J2-IN  
 Switch B is set to J1-IN  
 Switch C is set to J2-IN

# Advantages of Mini-Circuits Portable Test Equipment vs Network or Spectrum Analyzers

- Significantly less expensive (typically 1:10, or even less)
- Minimal training required for setup
- Portable, for use in the field (or in the design lab down the hall)
- Works almost anywhere you can connect to a PC
- Remote access, anywhere you can connect to the Internet
- Modular, “building block” components for flexibility: buy just what you need now, reconfigure it on the fly, & add just what you need as your needs change

# Key Building Blocks for your Test Setup

- Signal Generators
- Power Sensors
- Digital Step Attenuators
- Switch Matrices
- Frequency Counters
- I/O Control Boxes
- USB/SPI/RS232 Converters



*...and more to come*

# USB Synthesized Signal Generators 250 – 4000 MHz

**SSG-4000LH**



**Low Harmonics: -60 dBc**

**SSG-4000HP**



**High Power: +20 dBm**

Model No	Frequency Range (MHz)	Dynamic Range (dBm)	Power Supply (V)	Frequency Resolution (kHz)	Power Resolution (dB)
SSG-4000LH	250-4000	-60 to +10	24	5	0.25
SSG-4000HP		-50 to +20			

## Narrow Band Signal Generator

Model No	Frequency Range (MHz)	Dynamic Range (dBm)	Power Supply Via USB (V)	Frequency Resolution (kHz)	Power Step (dB)
SG-960	900 - 960	30dB	5	50	0.25



Additional model are available on request such as 684-800MHz, 1052-1145MHz, 1747-1807MHz, 2356-2556MHz, 4152-4261MHz

# USB Power Sensors

## Dynamic Range -30 dBm to +20 dBm

**PWR-6G 1-6000MHz**



50Ω (32-bit PC)

**PWR-6GHS 1-6000MHz**



50Ω (32/64-bit PC)

**PWR-8GHS 1-8000MHz**



50Ω (32/64-bit PC)

**PWR-4GHS 9KHz-4000MHz**



50Ω (32/64-bit PC)

**PWR-2GHS-75 100KHz-2000MHz**



75Ω (32/64-bit PC)

**PWR-2.5GHS-75 100KHz-2500MHz**



75Ω (32/64-bit PC)



**True RMS PWR-4RMS (50-4000MHz, -35 to +20dBm)  
coming soon!**

# USB/RS232 Digital Step Attenuators

1 – 4000 MHz      30 – 90 dB Attenuation

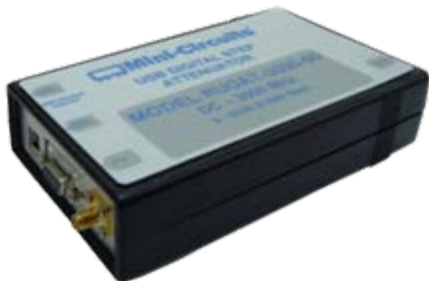

Model No	Frequency Range (MHz)	Attenuation Step (dB)	Dynamic Range (dB)
		Min	Max
RUDUT-2000-90	1 - 2000	0.5	90
RUDUT-3000-60	1 - 3000	0.5	60
RUDUT-3000-50	1 - 3000	0.5	50
RUDUT-4000-40	1 - 4000	0.5	40
RUDUT-4000-30	1 - 4000	0.5	30

# USB Switch Matrices

USB-1SPDT-A18



- Frequency Range DC – 18 GHz
- Isolation 85 dB
- Insertion Loss 0.2 dB
- High Power 10 W
- Switching Time 25 mSec
- Capable of 100 million cycles

USB-3SPDT-A18



USB-2SPDT-A18

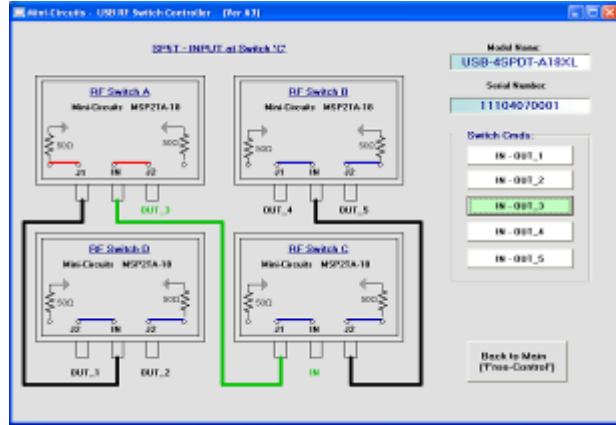

USB-4SPDT-A18



Switching States

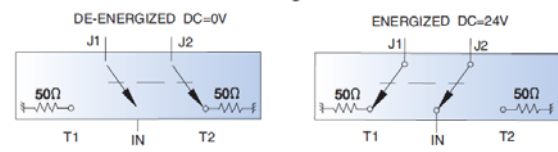

# USB Frequency Counter

## 1 – 6000 MHz

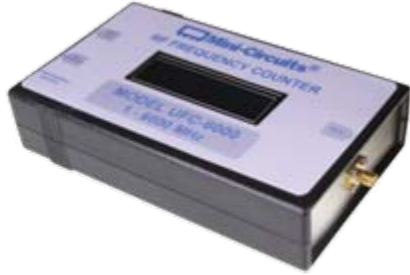

Model No	Frequency Range (MHz)	Frequency Range (Hz)			Frequency Accuracy (Hz)				Input Power (dBm)	10MHz Reference Input Power (dBm)
		1-40 MHz	40-200 MHz	200-6000 MHz	1-40 MHz	40-220 MHz	220-1500 MHz	1500-6000 MHz		
UFC-6000	1-6000	1	10	100	±2	±20	±200	±800	-28 to +13	-5 to +10



# USB I/O Control Boxes

## USB-I/O-4D2R



- Two DC 24V/0.375A opto-isolated relay outputs
- Four TTL/LVTTL outputs with a wide range of TTL voltage 2.7V to 5V

## USB-I/O-16D8R



- 8 electromechanical Form C buffered relays (dry contact outputs)
- 16 TTL/LVTTL digital I/O lines (2 Channels x 8 lines each)

## USB-I/O-8DRV



- 8 electromechanical Form C buffered relays (dry contact outputs)
- 8 TTL/LVTTL digital I/O lines
- 8 high voltage digital input lines (32 V, 14mA)

# USB ↔ SPI ↔ RS232 Converters

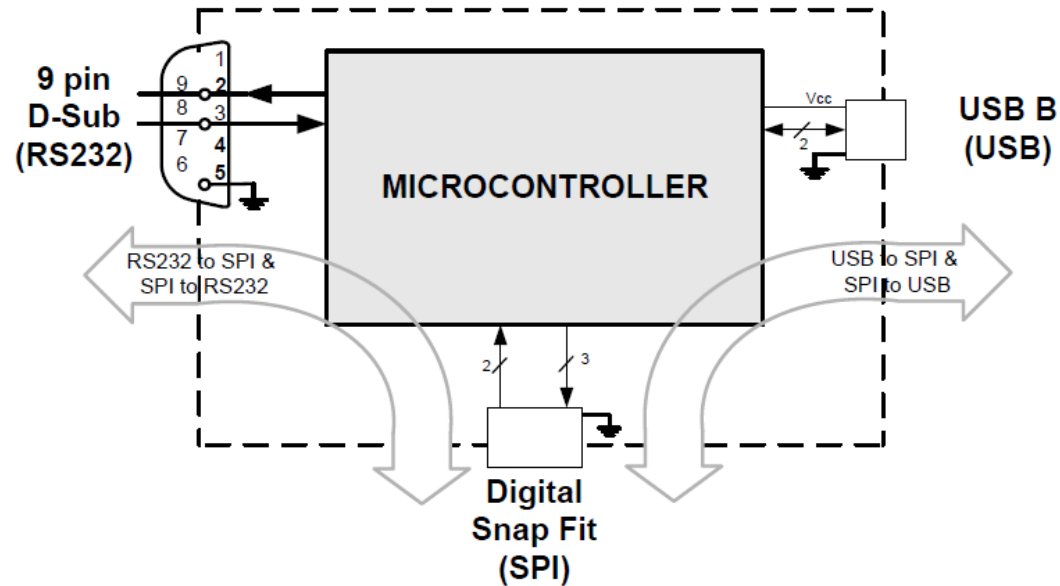

# Thank You

*more models are on the way — just keep an eye on  
[minicircuits.com](http://minicircuits.com)!*

