

# Engineering Development Model

## Power Splitter/Combiner

## QCV-ED13423C/3

### 2 Way-90°

#### Important Note

This model has been designed, built and tested in our engineering department. Performance data represents model capability. At present it is a non-catalog model. On request, we can supply a final specification sheet, part number and price/delivery information.



Please click "Back", and then click "Contact Us" for Applications support.

CASE STYLE : JV1210C-1

ELECTRICAL SPECIFICATIONS 50Ω @ +25°C				
Parameter	Min.	Typ.	Max.	Units
Frequency	150		265	MHz
Isolation		20		dB
Insertion Loss Average of Coupled Outputs above 3.0 dB		0.60		dB
Phase Unbalance		5.00		deg.
Amplitude Unbalance		0.30		dB
VSWR	SUM Port	1.20		(:1)
	OUT Ports	1.25		(:1)

MAXIMUM RATINGS	
Operating Temperature	-55°C to 100°C
Storage Temperature	-55°C to 100°C

PIN CONNECTIONS	
SUM PORT	1
PORT 1 (0°)	4
PORT 2 (90°)	6
50 TERM. EXTERNAL	3
GND	2,5

#### Functional Diagram

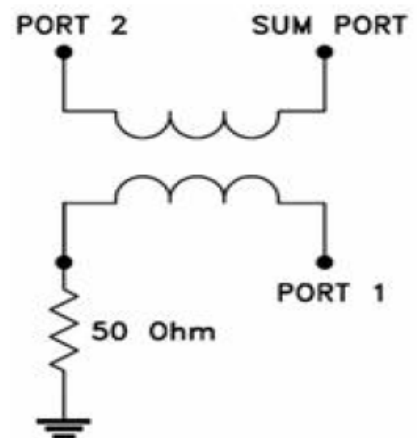

P.O. Box 350166, Brooklyn, New York 11235-0003 (718) 934-4500 • Fax (718) 332-4661 For detailed performance specs & shopping online see Mini-Circuits web site  
 The Design Engineers Search Engine Provides ACTUAL Data Instantly From MINI-CIRCUITS At: www.minicircuits.com

REV. X1  
 QCV-ED13423C/3  
 2/7/2011

Page 1 of 1