

top hat[®]
Surface Mount
Power Splitter/Combiner

SBTC-2-25X+

2 Way-0° 50Ω 1000 to 2500 MHz

Features

- wide band frequency, 1000-2500 MHz
- excellent amplitude unbalance, 0.2 dB typ.
- small size, 0.166"x0.150"x0.155"
- temperature stable LTCC base
- small size
- low cost
- aqueous washable
- protected by US patent 6,963,255

Applications

- PCN/PCS
- DECT
- PHS
- VSAT

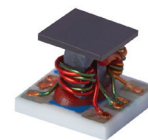

Generic photo used for illustration purposes only

CASE STYLE: AT1667

+RoHS Compliant

The +Suffix identifies RoHS Compliance. See our web site for RoHS Compliance methodologies and qualifications

Available Tape and Reel at no extra cost

Reel Size	Devices/Reel
13"	500

Electrical Specifications

Parameter	Frequency (MHz)	Min.	Typ.	Max.	Unit
Frequency Range		1000		2500	MHz
Insertion Loss Above 3.0 dB	1000 - 2500	—	1.4	2.5	dB
	1400 - 1800	—	0.9	1.7	
	1800 - 2000	—	1.0	1.7	
Isolation	1000 - 2500	14	20	—	dB
	1400 - 1800	14	18	—	
	1800 - 2000	16	19	—	
Phase Unbalance	1000 - 2500	—	—	14	Degree
	1400 - 1800	—	—	8	
	1800 - 2000	—	—	8	
Amplitude Unbalance	1000 - 2500	—	—	1.2	dB
	1400 - 1800	—	—	0.7	
	1800 - 2000	—	—	0.8	

Maximum Ratings

Parameter	Ratings
Operating Temperature	-40°C to 85°C
Storage Temperature	-55°C to 100°C
Power Input (as a splitter)	1W max.
Internal Dissipation	0.125W max

Permanent damage may occur if any of these limits are exceeded.

Pin Connections

Function	Pin Number
SUM PORT	6
PORT 1	3
PORT 2	4
GROUND	1,2
NOT USED	5

Product Marking

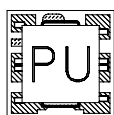

Electrical Schematic

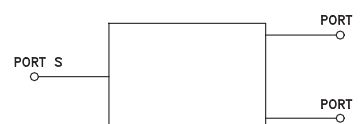

Outline Drawing

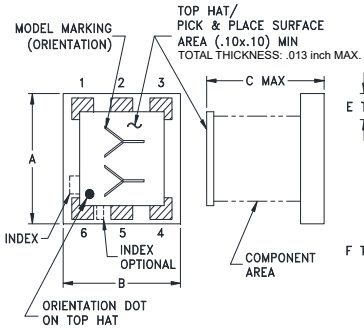

PCB Land Pattern

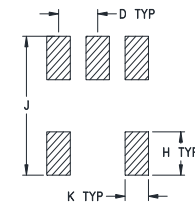

Suggested Layout,
Tolerance to be within ±.002

Outline Dimensions (inch/mm)

A	B	C	D	E	F
.150	.150	.150	.050	.030	.025
3.81	3.81	3.81	1.27	0.76	0.64
G	H	J	K	wt	
.028	.050	.160	.030	grams	
0.71	1.27	4.06	0.76	0.10	

Demo Board MCL P/N: TB-274 Suggested PCB Layout (PL-152)

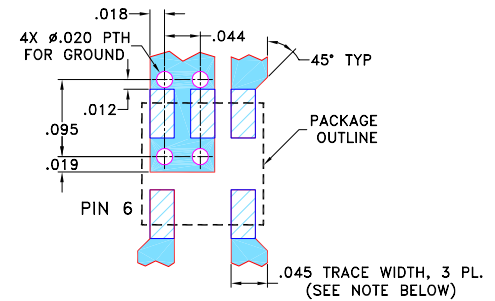

NOTE: 1. TRACE WIDTH IS SHOWN FOR ROGERS RO4350B WITH DIELECTRIC THICKNESS 0.020" ± 0.0015"; COPPER: 1/2 OZ. EACH SIDE. FOR OTHER MATERIALS TRACE WIDTH MAY NEED TO BE MODIFIED.
2. BOTTOM SIDE OF THE PCB IS CONTINUOUS GROUND PLANE.

- DENOTES PCB COPPER LAYOUT WITH SMOBC (SOLDER MASK OVER BARE COPPER)
- DENOTES COPPER LAND PATTERN FREE OF SOLDER MASK

Typical Performance Data

Frequency (MHz)	Total Loss ¹ (dB)		Amplitude Unbalance (dB)	Isolation (dB)	Phase Unbalance (deg.)	VSWR S	VSWR 1	VSWR 2
	S-1	S-2						
1000	4.10	3.83	0.28	22.47	2.79	1.72	1.68	1.57
1100	4.07	3.85	0.21	21.47	2.54	1.66	1.59	1.51
1200	4.05	3.90	0.15	20.62	2.39	1.61	1.51	1.46
1300	4.01	3.93	0.08	19.92	2.34	1.56	1.45	1.41
1400	3.98	3.96	0.04	19.49	2.36	1.51	1.39	1.36
1500	3.96	4.00	0.05	19.21	2.47	1.47	1.33	1.32
1600	3.93	4.03	0.10	19.18	2.66	1.42	1.28	1.27
1700	3.90	4.06	0.16	19.29	2.92	1.37	1.24	1.23
1800	3.88	4.09	0.21	19.68	3.28	1.32	1.21	1.18
1900	3.86	4.12	0.27	20.37	3.70	1.26	1.19	1.14
2000	3.84	4.16	0.32	21.53	4.23	1.20	1.18	1.10
2100	3.83	4.21	0.37	23.36	4.87	1.13	1.18	1.08
2200	3.84	4.26	0.42	26.19	5.57	1.06	1.18	1.10
2300	3.88	4.34	0.46	28.88	6.36	1.09	1.18	1.15
2500	4.08	4.63	0.55	21.85	8.22	1.39	1.15	1.30

1. Total Loss = Insertion Loss + 3dB splitter loss.

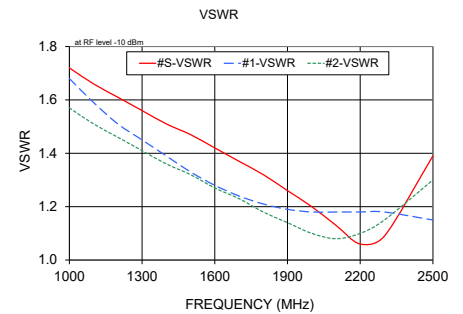
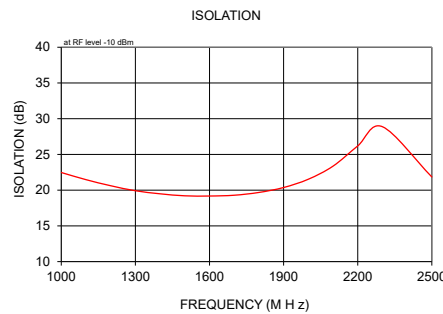
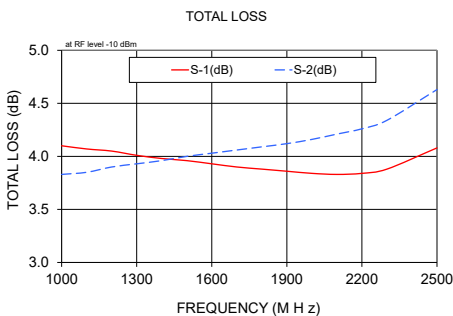

Additional Notes

- Performance and quality attributes and conditions not expressly stated in this specification document are intended to be excluded and do not form a part of this specification document.
- Electrical specifications and performance data contained in this specification document are based on Mini-Circuit's applicable established test performance criteria and measurement instructions.
- The parts covered by this specification document are subject to Mini-Circuits standard limited warranty and terms and conditions (collectively, "Standard Terms"); Purchasers of this part are entitled to the rights and benefits contained therein. For a full statement of the Standard Terms and the exclusive rights and remedies thereunder, please visit Mini-Circuits' website at www.minicircuits.com/MCLStore/terms.jsp