

# Frequency Synthesizer

SSN-2685A-119+

50Ω 2495 to 2690 MHz

## The Big Deal

- Fractional N synthesizer
- Low phase noise and spurious
- Robust design and construction
- Very small size 0.60" x 0.60" x 0.138"



CASE STYLE: KJ1367

## Product Overview

The SSN-2685A-119+ is a Frequency Synthesizer, designed to operate from 2495 to 2690 MHz for WiMAX application. The SSN-2685A-119+ is packaged in a metal case (size of 0.60" x 0.60" x 0.138") to shield against unwanted signals and noise.

## Key Features

Feature	Advantages
Low phase noise and spurious: <ul style="list-style-type: none"><li>• Phase Noise: -97 dBc/Hz typ. @ 10 kHz offset</li><li>• Step Size Spurious: -92 dBc typ.</li><li>• Comparison Spurious: -99 dBc typ.</li><li>• Reference Spurious: -92 dBc typ.</li></ul>	Low phase noise and spurious improve system EVM (Error Vector Magnitude).
Robust design and construction	To enhance the robustness of SSN-2685A-119+, each internal component is secured to the substrate with chip bonder, thereby eliminating the risk of tombstoning during subsequent solder reflow operations by the customer.
Small size, 0.60" x 0.60" x 0.138"	The small size enables the SSN-2685A-119+ to be used in compact designs.

### Notes

- A. Performance and quality attributes and conditions not expressly stated in this specification document are intended to be excluded and do not form a part of this specification document.  
B. Electrical specifications and performance data contained in this specification document are based on Mini-Circuit's applicable established test performance criteria and measurement instructions.  
C. The parts covered by this specification document are subject to Mini-Circuits standard limited warranty and terms and conditions (collectively, "Standard Terms"); Purchasers of this part are entitled to the rights and benefits contained therein. For a full statement of the Standard Terms and the exclusive rights and remedies thereunder, please visit Mini-Circuits' website at [www.minicircuits.com/MCLStore/terms.jsp](http://www.minicircuits.com/MCLStore/terms.jsp)



Surface Mount

# Frequency Synthesizer

SSN-2685A-119+

50Ω 2495 to 2690 MHz

## Features

- Fractional N synthesizer
- Integrated VCO + PLL
- Low phase noise and spurious
- Robust design and construction
- Low operating voltage (VCC VCO=+4.85V, VCC PLL=+3.2V)
- Small size 0.60" x 0.60" x 0.138"



CASE STYLE: KJ1367

**+RoHS Compliant**

The +Suffix identifies RoHS Compliance. See our web site for RoHS Compliance methodologies and qualifications

## Applications

- WiMAX

## General Description

The SSN-2685A-119+ is a Frequency Synthesizer, designed to operate from 2495 to 2690 MHz for WiMAX application. The SSN-2685A-119+ is packaged in a metal case (size of 0.60" x 0.60" x 0.138") to shield against unwanted signals and noise. To enhance the robustness of SSN-2685A-119+, each internal component is secured to the substrate with chip bonder, thereby eliminating the risk of tombstoning during subsequent solder reflow operations by the customer.

## Simplified Schematic

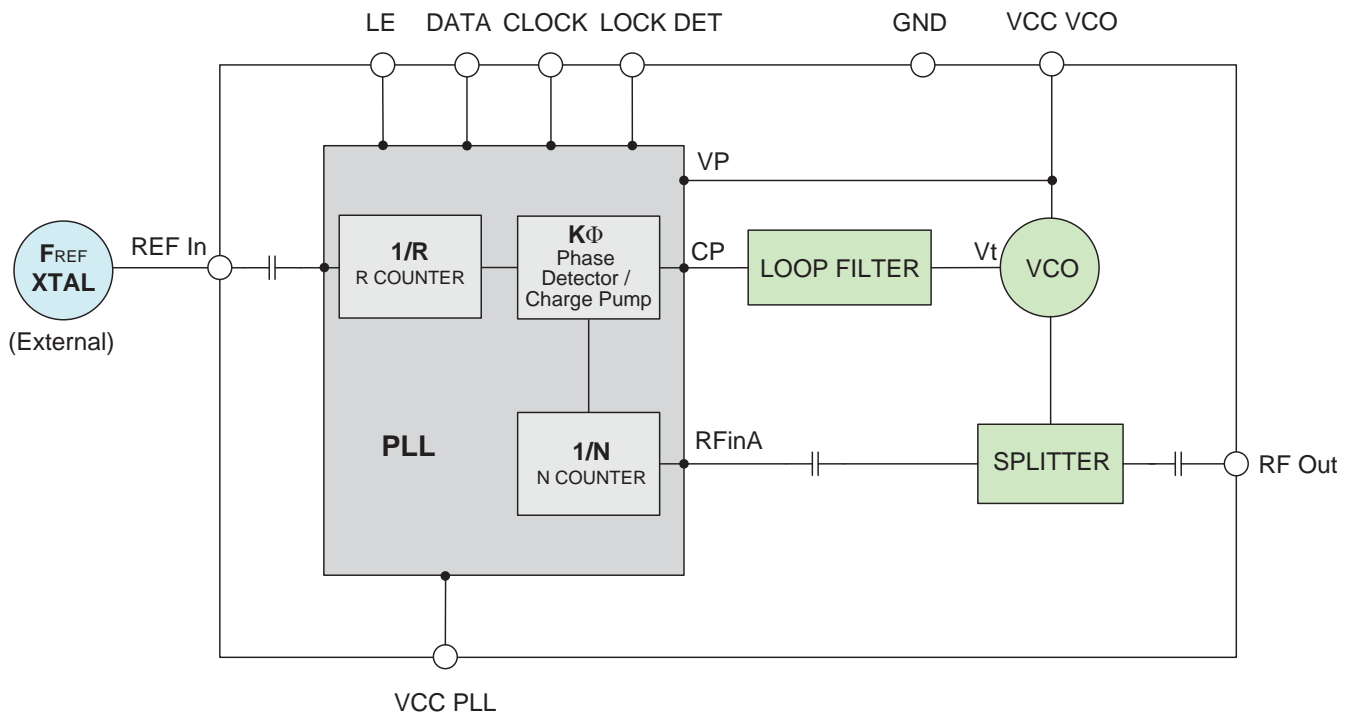

### Notes

- Performance and quality attributes and conditions not expressly stated in this specification document are intended to be excluded and do not form a part of this specification document.
- Electrical specifications and performance data contained in this specification document are based on Mini-Circuit's applicable established test performance criteria and measurement instructions.
- The parts covered by this specification document are subject to Mini-Circuits standard limited warranty and terms and conditions (collectively, "Standard Terms"); Purchasers of this part are entitled to the rights and benefits contained therein. For a full statement of the Standard Terms and the exclusive rights and remedies thereunder, please visit Mini-Circuits' website at [www.minicircuits.com/MCLStore/terms.jsp](http://www.minicircuits.com/MCLStore/terms.jsp)



[www.minicircuits.com](http://www.minicircuits.com) P.O. Box 350166, Brooklyn, NY 11235-0003 (718) 934-4500 sales@minicircuits.com

REV. B  
M151108  
EDR-8858/3F1  
SSN-2685A-119+  
Category-A2  
RAV  
151012  
Page 2 of 13

**Electrical Specifications** (over operating temperature -40°C to +85°C)

Parameters	Test Conditions	Min.	Typ.	Max.	Units
Frequency Range	-	2495	-	2690	MHz
Step Size	-	-	250	-	kHz
Comparison Frequency	-	-	26	-	MHz
Settling Time	Within ± 1 kHz	-	25	50	mSec
Output Power	-	0	+3	+6	dBm
SSB Phase Noise	@ 100 Hz offset	-	-80	-	dBc/Hz
	@ 1 kHz offset	-	-88	-84	
	@ 10 kHz offset	-	-96	-91	
	@ 100 kHz offset	-	-123	-118	
	@ 1 MHz offset	-	-143	-138	
Integrated SSB Phase Noise	@1kHz to 10MHz	-	-50	-	dBc
Step Size Spurious Suppression	Step Size 250 kHz	-	-80	-68	dBc
0.5 Step Size Spurious Suppression	0.5 Step Size 125 kHz	-	-75	-67	
Reference Spurious Suppression	Ref. Freq. 52 MHz	-	-85	-73	
Comparison Spurious Suppression	Comp. Freq. 26 MHz	-	-94	-87	
Non - Harmonic Spurious Suppression	-	-	-90	-	
Harmonic Suppression	-	-	-33	-26	
VCO Supply Voltage	+4.85	+4.75	+4.85	+5.25	V
PLL Supply Voltage	+3.20	+3.10	+3.20	+3.30	V
VCO Supply Current	-	-	45	52	mA
PLL Supply Current	-	-	18	24	
Reference Input (External)	Frequency	52 (square wave)	-	52	MHz
	Amplitude	1	-	1	V <sub>P-P</sub>
	Input impedance	-	-	100	KΩ
	Phase Noise @ 1 kHz offset	-	-	-135	dBc/Hz
RF Output port Impedance	-	-	50	-	Ω
Input Logic Level	Input high voltage	-	2.65	-	V
	Input low voltage	-	-	0.60	V
Digital Lock Detect	Locked	-	2.70	-	3.30
	Unlocked	-	-	-	0.40
Frequency Synthesizer PLL	-	ADF4153			
PLL Programming	-	3-wire serial 3.2V CMOS			
Register Map @ 2690 MHz	R0_Register	-	(MSB) 110011100000011000000 (LSB)		
	R1_Register	-	(MSB) 101001000000110100001 (LSB)		
	R2_Register	-	(MSB) 111100010 (LSB)		
	R3_Register	-	(MSB) 1111000111 (LSB)		

**Absolute Maximum Ratings**

Parameters	Ratings
VCO Supply Voltage	5.8V
PLL Supply Voltage	4.0V
VCO Supply Voltage to PLL Supply Voltage	-0.3V to +5.8V
Reference Frequency Voltage	-0.3Vmin, VCC PLL +0.3Vmax
Data, Clock, LE Levels	-0.3Vmin, VCC PLL +0.3Vmax
Operating Temperature	-40°C to +85°C
Storage Temperature	-55°C to +100°C

Permanent damage may occur if any of these limits are exceeded

**Notes**

- A. Performance and quality attributes and conditions not expressly stated in this specification document are intended to be excluded and do not form a part of this specification document.
- B. Electrical specifications and performance data contained in this specification document are based on Mini-Circuit's applicable established test performance criteria and measurement instructions.
- C. The parts covered by this specification document are subject to Mini-Circuits standard limited warranty and terms and conditions (collectively, "Standard Terms"); Purchasers of this part are entitled to the rights and benefits contained therein. For a full statement of the Standard Terms and the exclusive rights and remedies thereunder, please visit Mini-Circuits' website at [www.minicircuits.com/MCLStore/terms.jsp](http://www.minicircuits.com/MCLStore/terms.jsp)



Typical Performance Data

FREQUENCY (MHz)	POWER OUTPUT (dBm)			VCO CURRENT (mA)			PLL CURENT (mA)		
	-45°C	+25°C	+85°C	-45°C	+25°C	+85°C	-45°C	+25°C	+85°C
2495.0	3.12	2.48	1.95	44.54	46.02	46.88	14.73	16.09	18.68
2506.5	3.45	2.76	2.23	44.55	46.06	46.90	15.34	16.73	19.33
2528.0	3.73	3.37	2.60	44.62	46.09	46.96	15.02	16.40	18.98
2549.5	3.79	3.24	2.73	44.73	46.17	47.07	14.75	16.14	18.69
2571.0	3.82	3.27	2.75	44.78	46.21	47.10	14.95	16.34	18.90
2592.5	3.86	3.31	2.55	44.74	46.21	47.07	15.19	16.58	19.16
2614.0	4.08	3.49	2.60	44.72	46.11	47.07	15.29	16.69	19.26
2635.5	4.31	3.64	2.81	44.63	46.02	47.02	15.27	16.68	19.24
2657.0	4.03	3.30	2.66	44.49	45.95	46.96	15.08	16.49	19.05
2678.5	3.64	3.02	2.41	44.33	45.84	46.90	14.63	16.02	18.55
2690.0	3.46	2.84	2.26	44.22	45.76	46.87	15.29	16.70	19.27

FREQUENCY (MHz)	HARMONICS (dBc)					
	F2			F3		
	-45°C	+25°C	+85°C	-45°C	+25°C	+85°C
2495.0	-33.01	-35.24	-35.13	-54.74	-51.63	-45.19
2506.5	-36.30	-34.24	-36.68	-53.29	-52.22	-46.07
2528.0	-36.32	-38.74	-37.14	-53.11	-55.78	-46.34
2549.5	-36.48	-36.95	-38.19	-50.05	-54.38	-49.38
2571.0	-37.33	-37.11	-38.53	-52.43	-54.39	-53.01
2592.5	-44.03	-41.04	-41.10	-53.38	-50.14	-52.53
2614.0	-42.78	-43.04	-41.39	-52.33	-49.07	-54.08
2635.5	-43.08	-41.41	-44.16	-49.71	-46.19	-51.02
2657.0	-44.71	-42.25	-43.44	-46.84	-43.96	-48.66
2678.5	-42.03	-41.12	-43.61	-43.99	-43.01	-46.82
2690.0	-42.19	-41.03	-43.36	-42.14	-42.44	-45.05

Notes

- A. Performance and quality attributes and conditions not expressly stated in this specification document are intended to be excluded and do not form a part of this specification document.
- B. Electrical specifications and performance data contained in this specification document are based on Mini-Circuit's applicable established test performance criteria and measurement instructions.
- C. The parts covered by this specification document are subject to Mini-Circuits standard limited warranty and terms and conditions (collectively, "Standard Terms"); Purchasers of this part are entitled to the rights and benefits contained therein. For a full statement of the Standard Terms and the exclusive rights and remedies thereunder, please visit Mini-Circuits' website at [www.minicircuits.com/MCLStore/terms.jsp](http://www.minicircuits.com/MCLStore/terms.jsp)



FREQUENCY (MHz)	PHASE NOISE (dBc/Hz) @OFFSETS				
	+25°C				
	100Hz	1kHz	10kHz	100kHz	1MHz
2495.0	-84.58	-90.07	-99.74	-126.24	-146.60
2506.5	-86.75	-91.04	-98.30	-125.61	-145.83
2528.0	-86.15	-88.69	-98.36	-125.77	-146.54
2549.5	-86.80	-91.21	-98.16	-125.73	-146.02
2571.0	-84.13	-92.22	-97.76	-126.37	-146.66
2592.5	-89.22	-88.97	-97.24	-125.97	-145.92
2614.0	-84.12	-90.43	-96.62	-125.08	-145.85
2635.5	-85.67	-91.71	-96.69	-124.70	-145.40
2657.0	-86.43	-88.63	-97.24	-124.71	-145.19
2678.5	-86.15	-90.44	-96.19	-124.29	-143.50
2690.0	-88.16	-89.40	-97.49	-123.97	-144.35

FREQUENCY (MHz)	PHASE NOISE (dBc/Hz) @OFFSETS				
	-45°C				
	100Hz	1kHz	10kHz	100kHz	1MHz
2495.0	-86.61	-93.31	-99.39	-127.74	-148.34
2506.5	-86.48	-92.40	-98.59	-126.33	-147.54
2528.0	-87.00	-89.96	-97.95	-126.84	-147.88
2549.5	-86.74	-90.78	-97.70	-127.16	-147.99
2571.0	-86.10	-89.58	-97.81	-127.38	-148.28
2592.5	-90.61	-92.05	-97.54	-126.77	-148.47
2614.0	-86.33	-91.12	-97.75	-127.13	-148.41
2635.5	-84.64	-90.68	-97.41	-126.96	-148.03
2657.0	-84.91	-89.85	-97.86	-126.10	-147.26
2678.5	-85.92	-90.57	-97.70	-125.93	-146.89
2690.0	-87.61	-89.26	-97.56	-125.63	-146.39

FREQUENCY (MHz)	PHASE NOISE (dBc/Hz) @OFFSETS				
	+85°C				
	100Hz	1kHz	10kHz	100kHz	1MHz
2495.0	-87.68	-90.49	-97.74	-123.90	-144.08
2506.5	-87.54	-90.47	-97.51	-123.54	-142.96
2528.0	-82.71	-91.45	-97.26	-123.26	-143.49
2549.5	-84.32	-88.58	-96.95	-123.82	-143.86
2571.0	-83.73	-90.41	-96.75	-123.64	-144.26
2592.5	-84.62	-89.88	-96.47	-123.14	-143.89
2614.0	-84.59	-90.60	-96.68	-123.22	-143.93
2635.5	-84.51	-90.88	-96.04	-123.23	-143.26
2657.0	-83.63	-89.50	-95.69	-122.36	-142.95
2678.5	-82.76	-88.25	-95.50	-122.06	-142.37
2690.0	-84.16	-89.32	-95.24	-121.79	-142.07

Notes

- A. Performance and quality attributes and conditions not expressly stated in this specification document are intended to be excluded and do not form a part of this specification document.
- B. Electrical specifications and performance data contained in this specification document are based on Mini-Circuit's applicable established test performance criteria and measurement instructions.
- C. The parts covered by this specification document are subject to Mini-Circuits standard limited warranty and terms and conditions (collectively, "Standard Terms"); Purchasers of this part are entitled to the rights and benefits contained therein. For a full statement of the Standard Terms and the exclusive rights and remedies thereunder, please visit Mini-Circuits' website at [www.minicircuits.com/MCLStore/terms.jsp](http://www.minicircuits.com/MCLStore/terms.jsp)



COMPARISON SPURIOUS ORDER	COMPARISON SPURIOUS @Fcarrier 2495MHz+(n*Fcomparison) (dBc) note 1			COMPARISON SPURIOUS @Fcarrier 2593MHz+(n*Fcomparison) (dBc) note 1			COMPARISON SPURIOUS @Fcarrier 2690MHz+(n*Fcomparison) (dBc) note 1		
	n	-45°C	+25°C	+85°C	-45°C	+25°C	+85°C	-45°C	+25°C
-5	-101.79	-96.67	-104.53	-97.01	-99.42	-100.09	-96.70	-95.97	-101.79
-4	-95.21	-105.06	-98.29	-97.72	-96.62	-97.93	-95.83	-97.62	-94.29
-3	-96.24	-99.00	-100.13	-95.41	-98.11	-99.01	-95.64	-95.22	-101.83
-2	-102.14	-106.94	-115.60	-105.14	-108.39	-98.19	-103.57	-103.30	-99.78
-1	-95.54	-98.39	-102.61	-98.27	-103.57	-98.37	-97.88	-95.64	-101.53
0 <sup>note 2</sup>	-	-	-	-	-	-	-	-	-
+1	-97.46	-100.91	-100.21	-109.13	-99.95	-100.74	-100.49	-103.40	-103.22
+2	-102.70	-103.46	-103.21	-102.19	-103.96	-101.88	-104.88	-99.05	-101.18
+3	-100.59	-97.26	-98.30	-100.24	-97.48	-101.21	-100.47	-102.32	-102.86
+4	-97.66	-99.49	-96.79	-97.46	-96.11	-96.39	-97.28	-96.42	-95.78
+5	-100.04	-96.28	-100.31	-99.00	-98.11	-102.82	-100.55	-104.35	-110.31

Note 1: Comparison frequency 26 MHz

Note 2: All spurs are referenced to carrier signal (n=0).

REFERENCE SPURIOUS ORDER	REFERENCE SPURIOUS @Fcarrier 2495MHz+(n*Freference) (dBc) note 3			REFERENCE SPURIOUS @Fcarrier 2593MHz+(n*Freference) (dBc) note 3			REFERENCE SPURIOUS @Fcarrier 2690MHz+(n*Freference) (dBc) note 3		
	n	-45°C	+25°C	+85°C	-45°C	+25°C	+85°C	-45°C	+25°C
-5	-107.10	-108.44	-101.70	-98.22	-105.35	-107.73	-113.33	-103.42	-99.50
-4	-111.16	-96.93	-100.54	-95.75	-95.36	-90.94	-97.42	-97.20	-92.73
-3	-84.78	-88.69	-92.05	-95.59	-94.70	-95.96	-93.64	-96.29	-95.52
-2	-94.62	-105.23	-98.73	-97.53	-96.54	-97.76	-95.83	-97.19	-94.36
-1	-101.72	-106.93	-118.89	-104.49	-106.00	-98.82	-103.88	-102.65	-99.22
0 <sup>note 4</sup>	-	-	-	-	-	-	-	-	-
+1	-102.86	-103.65	-102.76	-102.55	-102.80	-100.78	-106.02	-98.95	-100.89
+2	-97.37	-99.65	-96.67	-97.22	-96.41	-96.03	-97.31	-96.62	-95.71
+3	-83.69	-87.15	-91.39	-93.02	-94.80	-95.97	-96.38	-95.72	-97.83
+4	-101.88	-100.96	-105.76	-94.48	-93.26	-91.40	-103.65	-99.46	-95.49
+5	-106.86	-103.24	-121.25	-106.95	-111.32	-105.75	-103.89	-102.20	-99.62

Note 3: Reference frequency 52 MHz

Note 4: All spurs are referenced to carrier signal (n=0).

Notes

- A. Performance and quality attributes and conditions not expressly stated in this specification document are intended to be excluded and do not form a part of this specification document.
- B. Electrical specifications and performance data contained in this specification document are based on Mini-Circuit's applicable established test performance criteria and measurement instructions.
- C. The parts covered by this specification document are subject to Mini-Circuits standard limited warranty and terms and conditions (collectively, "Standard Terms"); Purchasers of this part are entitled to the rights and benefits contained therein. For a full statement of the Standard Terms and the exclusive rights and remedies thereunder, please visit Mini-Circuits' website at [www.minicircuits.com/MCLStore/terms.jsp](http://www.minicircuits.com/MCLStore/terms.jsp)



STEP SIZE SPURIOUS ORDER n	0.5 STEP SIZE & STEP SIZE SPURIOUS @Fcarrier 2495MHz+(n*Fstep size) (dBc) note 5			0.5 STEP SIZE & STEP SIZE SPURIOUS @Fcarrier 2593MHz+(n*Fstep size) (dBc) note 5			0.5 STEP SIZE & STEP SIZE SPURIOUS @Fcarrier 2690MHz+(n*Fstep size) (dBc) note 5		
	-45°C	+25°C	+85°C	-45°C	+25°C	+85°C	-45°C	+25°C	+85°C
-5.0	-111.71	-111.83	-113.01	-116.30	-110.24	-110.57	-110.84	-114.67	-113.87
-4.5	-110.39	-109.71	-114.51	-116.08	-117.31	-113.72	-109.64	-111.37	-117.30
-4.0	-82.62	-82.84	-92.45	-119.69	-115.18	-109.65	-115.07	-118.53	-114.31
-3.5	-112.08	-114.68	-116.07	-115.76	-110.31	-109.05	-113.39	-112.65	-112.92
-3.0	-111.69	-114.36	-114.50	-114.15	-106.35	-110.76	-106.70	-115.93	-109.46
-2.5	-102.91	-110.19	-104.92	-111.53	-111.64	-104.71	-110.93	-108.43	-106.29
-2.0	-101.75	-106.18	-110.58	-107.75	-109.72	-110.74	-110.09	-107.54	-107.74
-1.5	-104.25	-108.09	-102.65	-103.66	-104.75	-104.50	-100.43	-95.54	-105.57
-1.0	-97.72	-98.40	-99.18	-90.80	-94.71	-94.10	-88.38	-85.03	-94.35
-0.5	-88.02	-90.44	-87.36	-80.89	-78.09	-81.69	-72.84	-77.43	-87.38
0 <sup>note 6</sup>	-	-	-	-	-	-	-	-	-
+0.5	-87.41	-87.89	-88.58	-79.61	-79.74	-81.25	-72.82	-76.95	-84.97
+1.0	-101.35	-100.96	-99.49	-90.30	-96.82	-98.38	-88.43	-84.01	-94.10
+1.5	-103.11	-108.48	-102.75	-105.44	-104.66	-106.01	-101.41	-94.99	-105.50
+2.0	-103.54	-103.40	-111.92	-107.11	-106.18	-111.90	-107.95	-108.75	-108.49
+2.5	-100.99	-106.39	-103.70	-112.66	-110.92	-104.93	-110.67	-110.68	-104.98
+3.0	-111.21	-113.36	-116.98	-111.72	-108.15	-113.78	-111.61	-113.27	-110.15
+3.5	-112.28	-117.17	-116.60	-112.07	-109.24	-111.50	-114.92	-113.51	-114.72
+4.0	-82.84	-83.35	-92.18	-116.37	-114.32	-113.20	-115.73	-115.12	-111.68
+4.5	-108.60	-114.25	-118.34	-118.72	-112.99	-117.81	-113.32	-115.06	-114.84
+5.0	-106.76	-111.47	-114.60	-118.09	-111.30	-115.80	-111.29	-111.35	-115.36

Note 5: Step size 250 kHz

Note 6: All spurs are referenced to carrier signal (n=0).

Notes

- A. Performance and quality attributes and conditions not expressly stated in this specification document are intended to be excluded and do not form a part of this specification document.
- B. Electrical specifications and performance data contained in this specification document are based on Mini-Circuit's applicable established test performance criteria and measurement instructions.
- C. The parts covered by this specification document are subject to Mini-Circuits standard limited warranty and terms and conditions (collectively, "Standard Terms"); Purchasers of this part are entitled to the rights and benefits contained therein. For a full statement of the Standard Terms and the exclusive rights and remedies thereunder, please visit Mini-Circuits' website at [www.minicircuits.com/MCLStore/terms.jsp](http://www.minicircuits.com/MCLStore/terms.jsp)



Typical Performance Curves

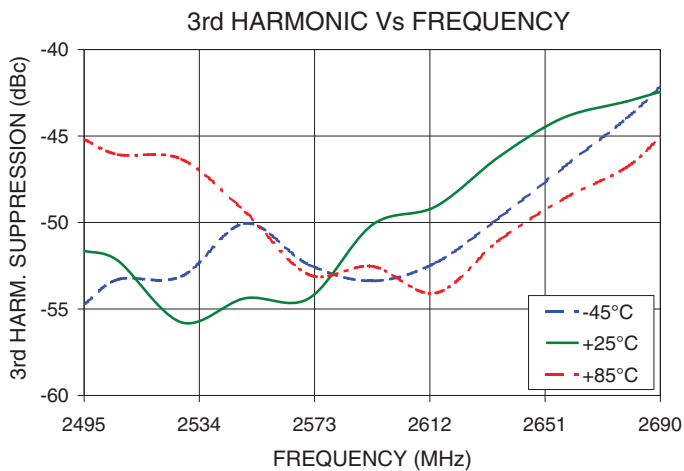
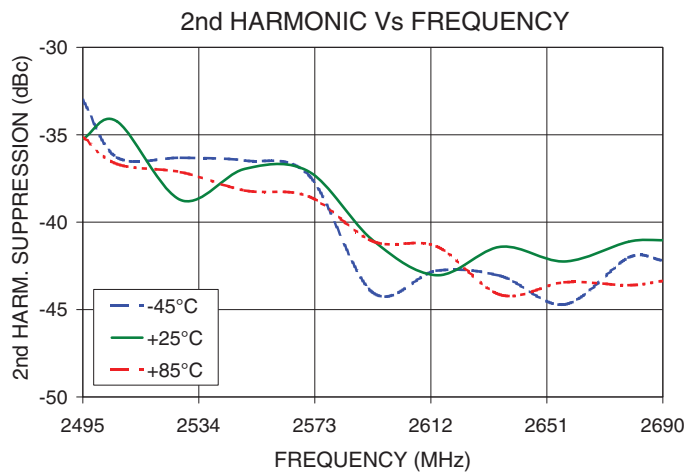
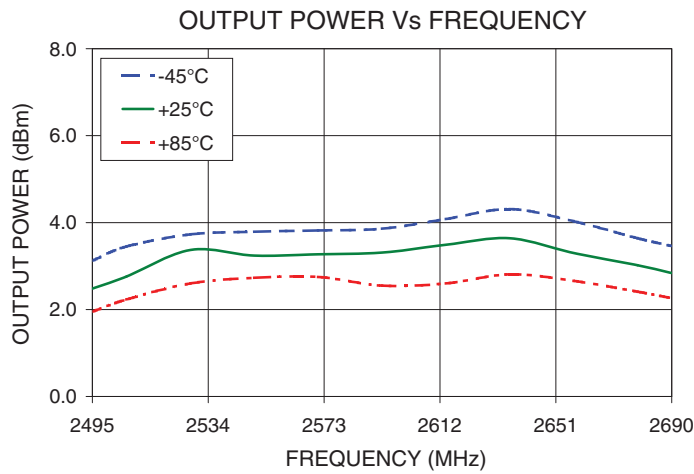

Notes

- A. Performance and quality attributes and conditions not expressly stated in this specification document are intended to be excluded and do not form a part of this specification document.
- B. Electrical specifications and performance data contained in this specification document are based on Mini-Circuit's applicable established test performance criteria and measurement instructions.
- C. The parts covered by this specification document are subject to Mini-Circuits standard limited warranty and terms and conditions (collectively, "Standard Terms"); Purchasers of this part are entitled to the rights and benefits contained therein. For a full statement of the Standard Terms and the exclusive rights and remedies thereunder, please visit Mini-Circuits' website at [www.minicircuits.com/MCLStore/terms.jsp](http://www.minicircuits.com/MCLStore/terms.jsp)





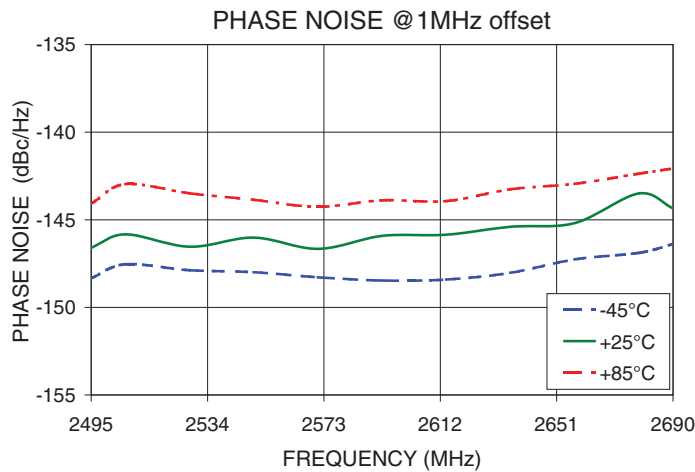
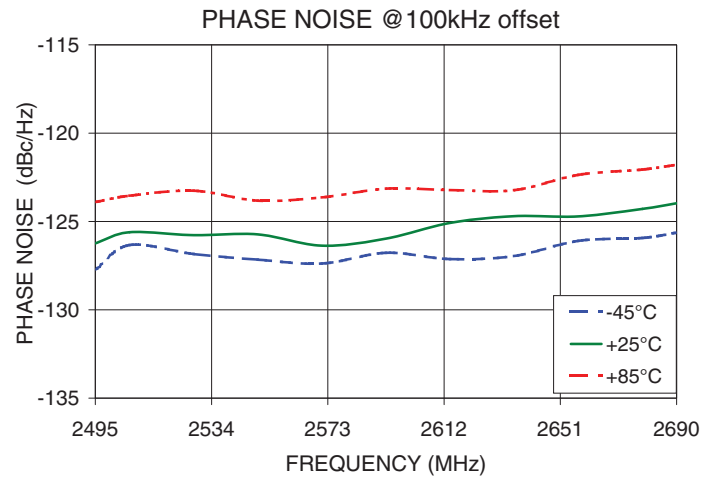
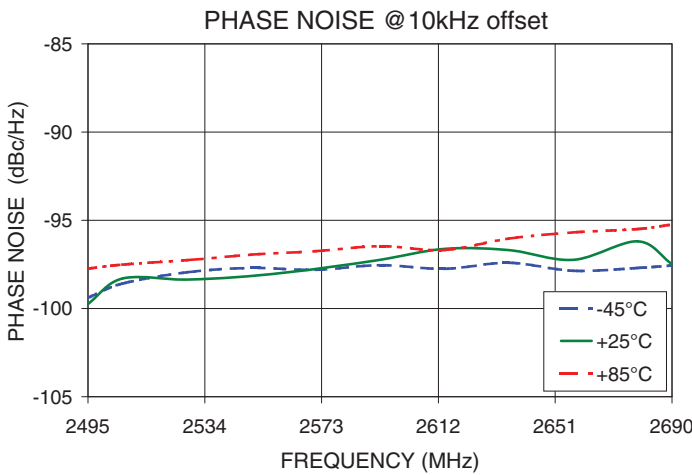
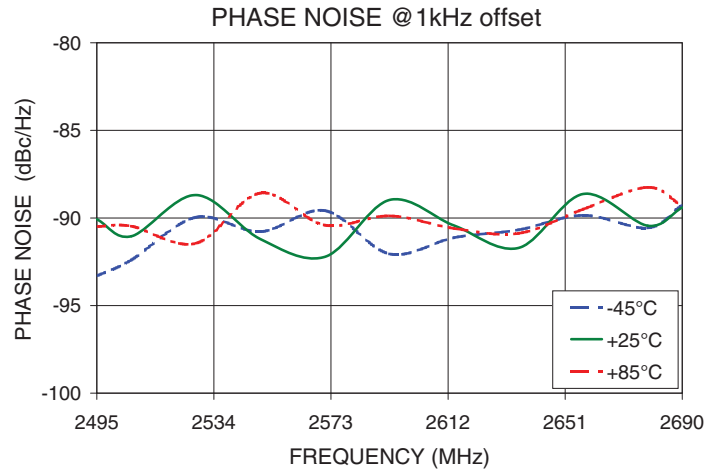
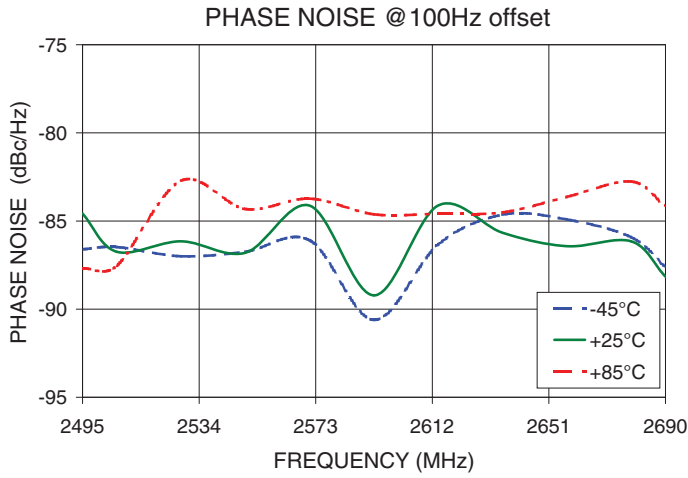

Notes

- A. Performance and quality attributes and conditions not expressly stated in this specification document are intended to be excluded and do not form a part of this specification document.
- B. Electrical specifications and performance data contained in this specification document are based on Mini-Circuit's applicable established test performance criteria and measurement instructions.
- C. The parts covered by this specification document are subject to Mini-Circuits standard limited warranty and terms and conditions (collectively, "Standard Terms"); Purchasers of this part are entitled to the rights and benefits contained therein. For a full statement of the Standard Terms and the exclusive rights and remedies thereunder, please visit Mini-Circuits' website at [www.minicircuits.com/MCLStore/terms.jsp](http://www.minicircuits.com/MCLStore/terms.jsp)



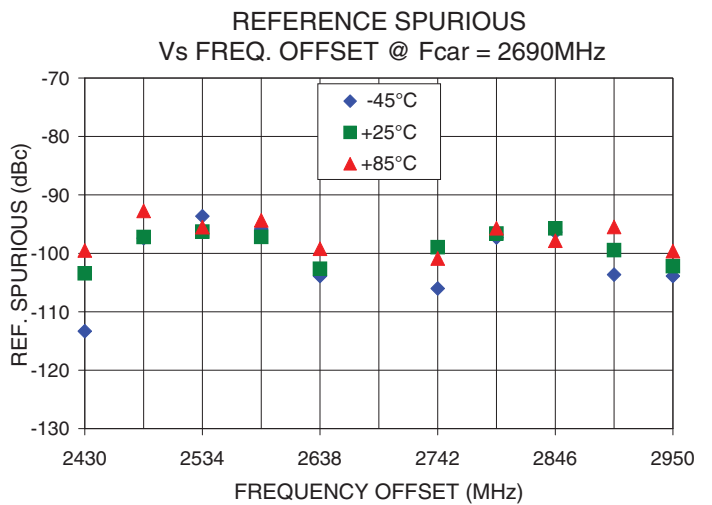
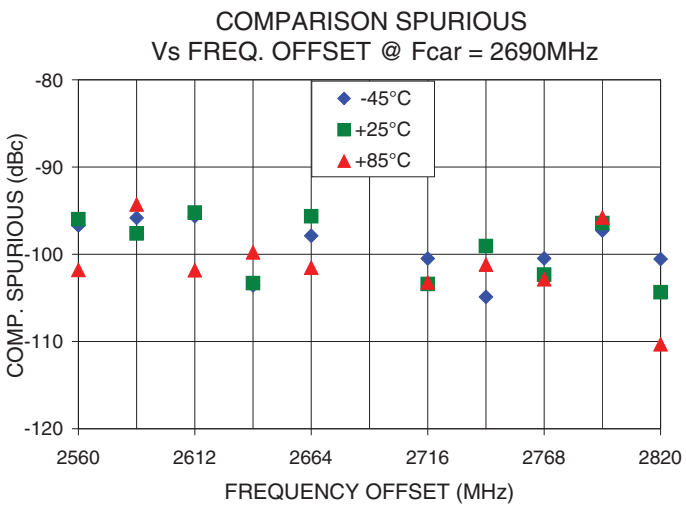
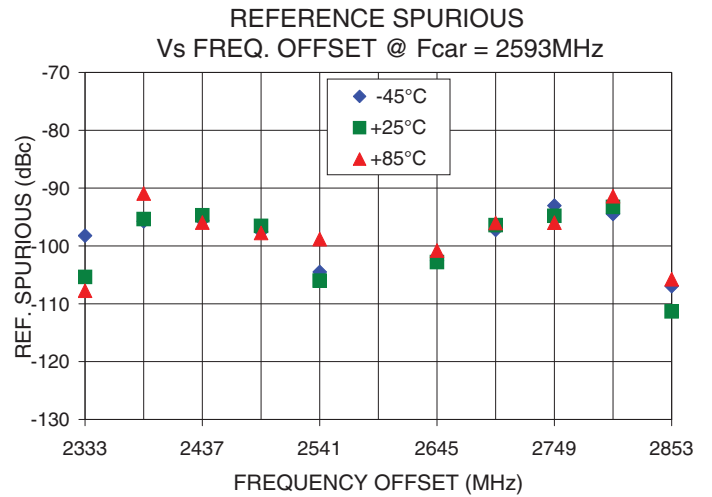
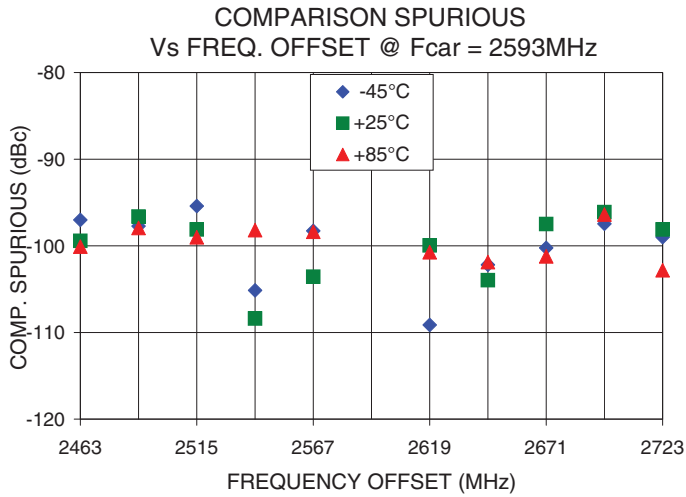
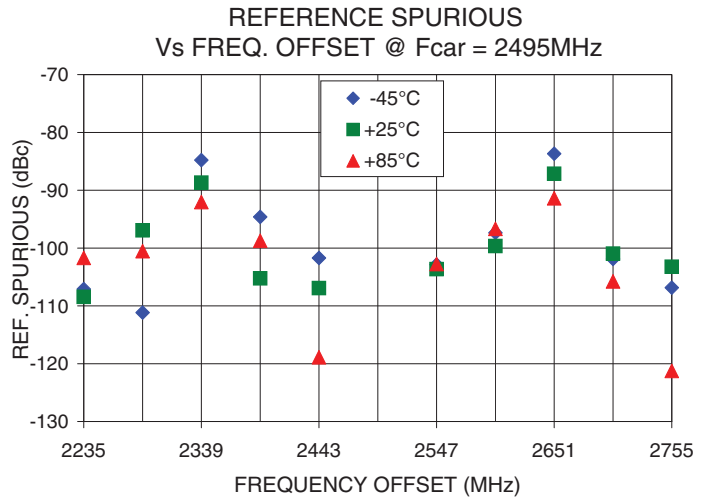
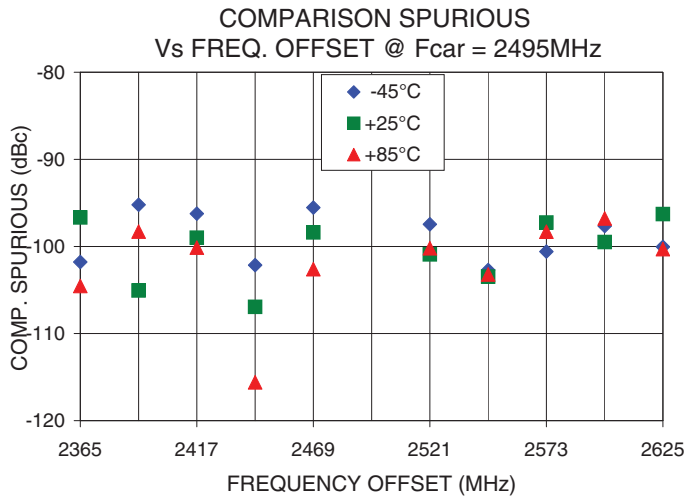

Notes

- A. Performance and quality attributes and conditions not expressly stated in this specification document are intended to be excluded and do not form a part of this specification document.
- B. Electrical specifications and performance data contained in this specification document are based on Mini-Circuit's applicable established test performance criteria and measurement instructions.
- C. The parts covered by this specification document are subject to Mini-Circuits standard limited warranty and terms and conditions (collectively, "Standard Terms"); Purchasers of this part are entitled to the rights and benefits contained therein. For a full statement of the Standard Terms and the exclusive rights and remedies thereunder, please visit Mini-Circuits' website at [www.minicircuits.com/MCLStore/terms.jsp](http://www.minicircuits.com/MCLStore/terms.jsp)



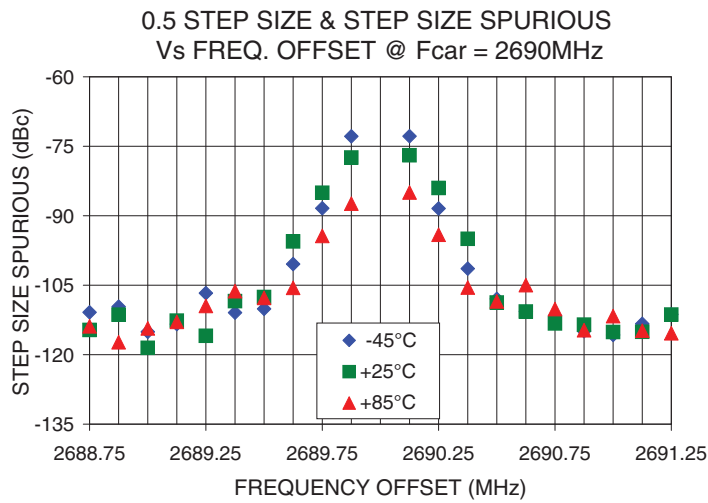
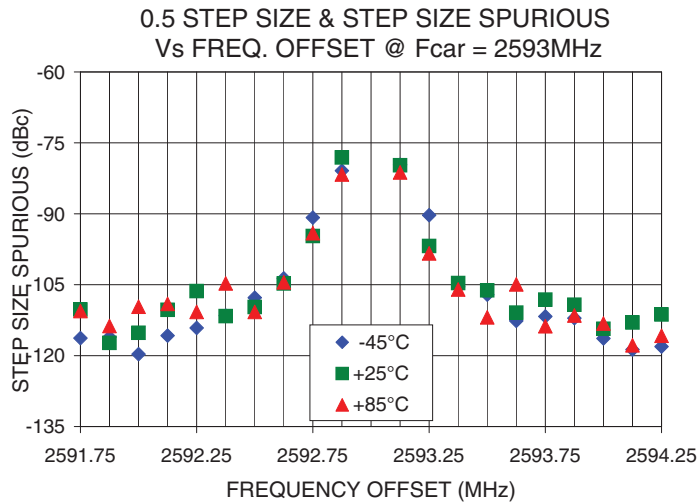
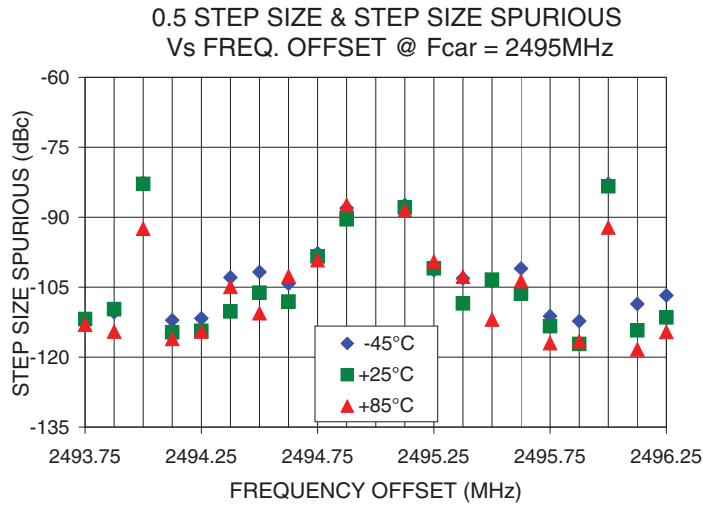

Notes

- A. Performance and quality attributes and conditions not expressly stated in this specification document are intended to be excluded and do not form a part of this specification document.
- B. Electrical specifications and performance data contained in this specification document are based on Mini-Circuit's applicable established test performance criteria and measurement instructions.
- C. The parts covered by this specification document are subject to Mini-Circuits standard limited warranty and terms and conditions (collectively, "Standard Terms"); Purchasers of this part are entitled to the rights and benefits contained therein. For a full statement of the Standard Terms and the exclusive rights and remedies thereunder, please visit Mini-Circuits' website at [www.minicircuits.com/MCLStore/terms.jsp](http://www.minicircuits.com/MCLStore/terms.jsp)



Pin Configuration

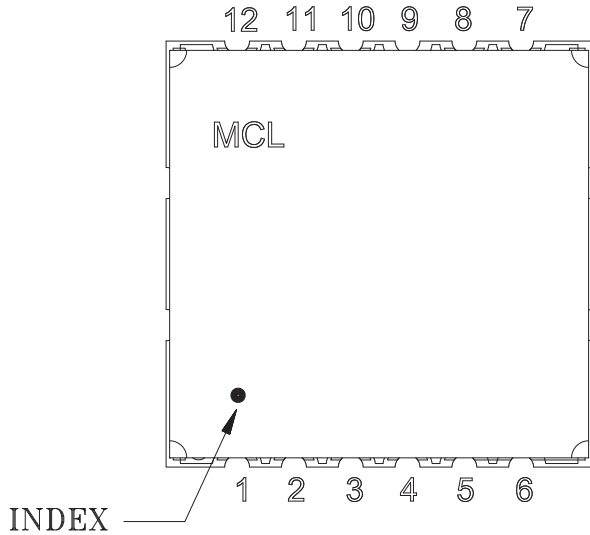

Pin Connection

Pin Number	Function
1	CLOCK
2	DATA
3	LE
4	REF IN
5	GND
6	GND
7	VCC VCO
8	GND
9	RF OUT
10	GND
11	LOCK DET
12	VCC PLL

Recommended Application Circuit

Note: REF IN and RF OUT ports are internally AC coupled.

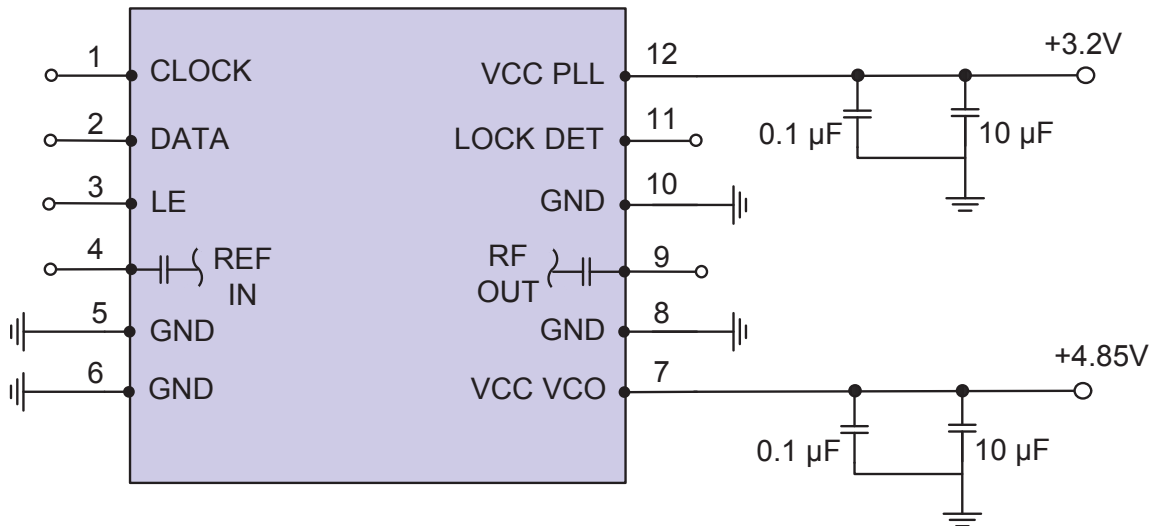

Notes

- A. Performance and quality attributes and conditions not expressly stated in this specification document are intended to be excluded and do not form a part of this specification document.
- B. Electrical specifications and performance data contained in this specification document are based on Mini-Circuits' applicable established test performance criteria and measurement instructions.
- C. The parts covered by this specification document are subject to Mini-Circuits standard limited warranty and terms and conditions (collectively, "Standard Terms"); Purchasers of this part are entitled to the rights and benefits contained therein. For a full statement of the Standard Terms and the exclusive rights and remedies thereunder, please visit Mini-Circuits' website at [www.minicircuits.com/MCLStore/terms.jsp](http://www.minicircuits.com/MCLStore/terms.jsp)



## Device Marking

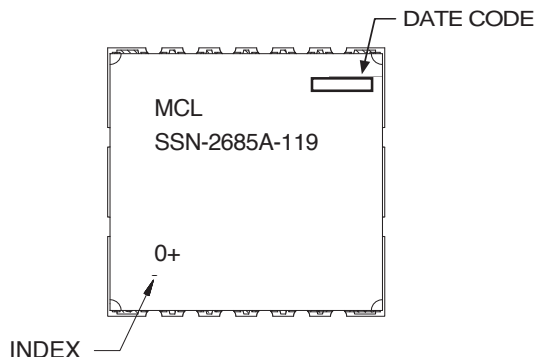

### Additional Detailed Technical Information

Additional information is available on our web site. To access this information enter the model number on our web site home page.

**Case Style:** KJ1367

**Tape & Reel:** TR-F95

**Suggested Layout for PCB Design:** PL-317

**Evaluation Board:** TB-552+

**Environment Ratings:** ENV65T2

#### Notes

- Performance and quality attributes and conditions not expressly stated in this specification document are intended to be excluded and do not form a part of this specification document.
- Electrical specifications and performance data contained in this specification document are based on Mini-Circuit's applicable established test performance criteria and measurement instructions.
- The parts covered by this specification document are subject to Mini-Circuits standard limited warranty and terms and conditions (collectively, "Standard Terms"); Purchasers of this part are entitled to the rights and benefits contained therein. For a full statement of the Standard Terms and the exclusive rights and remedies thereunder, please visit Mini-Circuits' website at [www.minicircuits.com/MCLStore/terms.jsp](http://www.minicircuits.com/MCLStore/terms.jsp)

