



**SURFACE MOUNT, HIGH POWER**

# Bi-Directional Coupler **SYDC-19-52VHP+**

50Ω 19 dB Coupling 30 to 512 MHz 60 Watt

## THE BIG DEAL

- High power handling, 60W
- Very low mainline loss, 0.3 dB
- Excellent VSWR, 1.05



*Generic photo used for illustration purposes only*

CASE STYLE: PD1647-1\*\*

*\*\*This model is not intended for pick & place use. Please contact Applications Dept. for assistance*

### +RoHS Compliant

The +Suffix identifies RoHS Compliance. See our website for methodologies and qualifications

## APPLICATIONS

- Military mobile

## PRODUCT OVERVIEW

Mini-Circuits' SYDC-19-52VHP+ surface mount bi-directional coupler provides exceptionally high power handling up to 60W and low mainline loss of 0.3 dB for applications from 30 to 512 MHz. This model features a unique heat sinking design that enables reliable operation at high power without overheating, making it an ideal choice for systems where high power capability and small size are desired. The coupler features core and wire construction mounted on an 8 -lead printed laminate base with wraparound terminations for excellent solderability. The unit measures 0.75 x 0.52 x 0.49", accommodating dense circuit board layouts.

## KEY FEATURES

Feature	Advantages
High power handling, 60W	Usable in many systems with high-power requirements
Low mainline loss, 0.08 dB	Provides excellent through-path signal power transmission.
Good directivity, up to 35 dB	High directivity allows accurate signal sampling through the coupled port with minimal measurement error.
Excellent return loss, up to 35 dB (input/output/coupling)	Provides excellent matching in 50Ω systems with minimal signal reflection.
Small size, 0.75 x 0.52 x 0.43"	Provides high power capability while saving space in systems with tight layouts.





# SURFACE MOUNT, HIGH POWER

# Bi-Directional Coupler SYDC-19-52VHP+



50Ω 19 dB Coupling 30 to 512 MHz 60 Watt

## ELECTRICAL SPECIFICATIONS<sup>1</sup> AT 25°C

Parameter	Condition (MHz)	Min.	Typ.	Max.	Units
Frequency Range		30		512	MHz
Mainline Loss (above theoretical loss 0.05 dB)	30	—	0.2	0.4	dB
	450	—	0.35	0.8	
	512	—	0.4	0.6	
Coupling	30-512	—	19.5±1.5	—	dB
Coupling Flatness(±)	30-512	—	0.4	0.6	dB
Directivity	30	22	35	—	dB
	450	18	25	—	
	512	16	22	—	
Return Loss (Input)	30	20	30	—	dB
	450	20	23	—	
	512	17	22	—	
Return Loss (Output)	30	26	31	—	dB
	450	23	26	—	
	512	18	24	—	
Return Loss (Coupling)	30	20	30	—	dB
	450	20	25	—	
	512	17	22	—	
Input Power <sup>2</sup>	30-512	—	—	60	W

1. Tested on Evaluation Board TB-SYDC1952VHP+

2. The user must provide adequate means of heat removal to limit the temperature of ground under the PCB to 65°C, in order to ensure proper performance. At 25°C ambient temperature this requires thermal resistance of the user's PC board heat sink to be 3.5°C/W or less when the unit is driven at maximum specified RF input power, 60W. At higher ambient temperature, with the same heat sink. Input power in watts must not exceed 60W x (65° C -Tambient)÷40°C.

## MAXIMUM RATINGS

Parameter	Ratings
Operating temperature	-40°C to 85°C Case*
Storage temperature	-55°C to 100°C

\*Case temperature is defined as temperature on ground leads. Permanent damage may occur if any of these limits are exceeded.

## ELECTRICAL SCHEMATIC

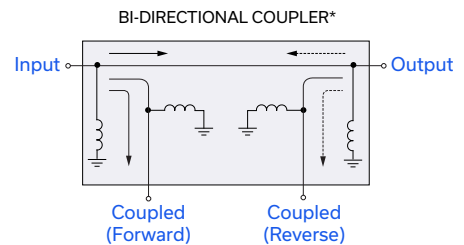

\*Electrical schematic is for Bi-Directional coupler with internal transformer(s) that routes DC from all ports to ground





# SURFACE MOUNT, HIGH POWER

# Bi-Directional Coupler SYDC-19-52VHP+

Mini-Circuits

50Ω 19 dB Coupling 30 to 512 MHz 60 Watt

## PAD CONNECTIONS

INPUT	1
OUTPUT	8
COUPLED (FORWARD)	4
COUPLED (REVERSE)	5
GROUND	2, 3, 6, 7

**\*PRODUCT MARKING:** SYDC-19-52VHP

\*Marking may contain other features or characters for internal lot control

**SUGGESTED PCB LAYOUT (PL-351)**  
REFER TO APPLICATION NOTE: [AN-00-017](#)

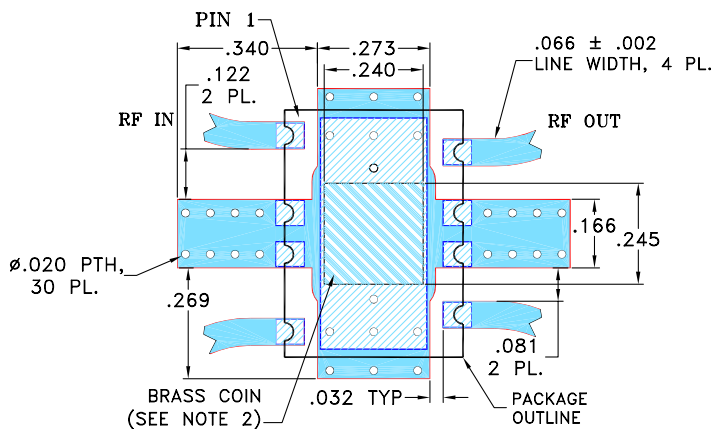

- NOTES:
- TRACE WIDTH IS SHOWN FOR ROGERS R04350B WITH DIELECTRIC THICKNESS .030" ± .002"; COPPER: 1/2 OZ. EACH SIDE. FOR OTHER MATERIALS TRACE WIDTH MAY NEED TO BE MODIFIED.
  - SUGGEST TO PROVIDE BRASS COIN FOR BETTER HEAT TRANSFER FROM THE UNIT. OTHERWISE PROVIDE ARRAY OF THERMAL VIAS ADEQUATE TO LIMIT TEMPERATURE OF GROUND CONNECTIONS UNDER THE UNIT TO 65°C.
  - BOTTOM SIDE OF THE PCB IS CONTINUOUS GROUND PLANE.

- DENOTES PCB COPPER LAYOUT WITH SMOBC (SOLDER MASK OVER BARE COPPER)
- DENOTES COPPER LAND PATTERN FREE OF SOLDER MASK
- DENOTES BRASS COIN.

## OUTLINE DRAWING

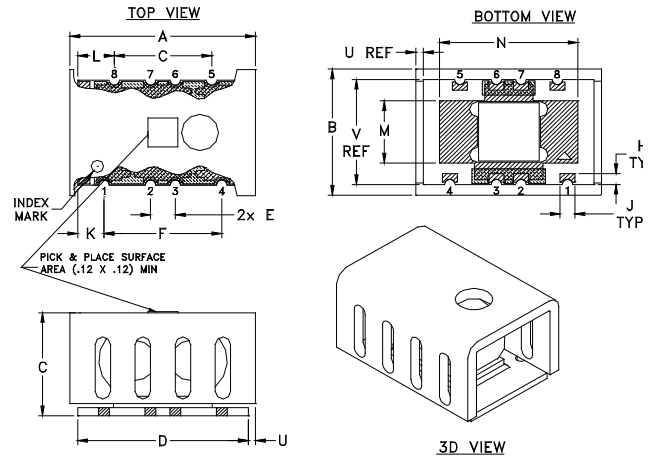

## PCB Land Pattern

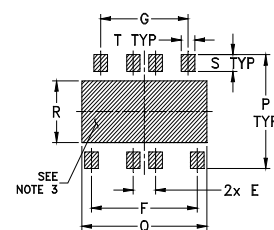

Suggested Layout,  
Tolerance to be within ±.002

## OUTLINE DIMENSIONS (Inches/mm)

A	B	C	D	E	F	G	H	J	K	L
.750	.520	.43	.690	.100	.476	.394	.045	.060	.276	.194
19.05	13.21	10.92	17.53	2.54	12.09	10.01	1.14	1.52	7.01	4.93
M	N	P	Q	R	S	T	U	V		wt
.257	.560	.475	.561	.258	.069	.061	.03	.433		grams
6.53	14.22	12.07	14.25	6.55	1.75	1.55	0.76	11.00		2.80

## TAPE & REEL INFORMATION: F115



**SURFACE MOUNT, HIGH POWER**

# Bi-Directional Coupler SYDC-19-52VHP+

50Ω 19 dB Coupling 30 to 512 MHz 60 Watt

## TYPICAL PERFORMANCE DATA

Frequency (MHz)	Mainline Loss (dB)	Coupling (dB)		Directivity (dB)		Return Loss (dB)			
		In-Out	In-Cpl Fwd	Out-Cpl Rev	Out-Cpl Fwd	In-Cpl Rev	In	Out	Cpl Fwd
30.00	0.20	19.53	19.39	35.44	35.50	30.87	32.42	31.49	32.72
100.00	0.23	19.66	19.57	35.65	35.56	34.30	36.09	34.74	36.52
150.00	0.23	19.70	19.66	34.87	33.97	36.74	37.48	35.35	38.24
200.00	0.25	19.73	19.73	33.09	33.07	35.32	36.68	34.82	37.69
300.00	0.28	19.77	19.86	29.46	29.31	31.78	34.90	31.48	36.27
350.00	0.31	19.79	19.91	27.51	27.57	29.37	33.28	29.43	35.15
400.00	0.33	19.80	19.93	25.71	25.76	27.22	31.60	27.29	33.32
450.00	0.36	19.81	19.94	23.69	23.83	25.29	29.58	25.50	31.16
500.00	0.40	19.82	19.91	21.89	21.95	23.53	27.79	23.80	29.02
512.00	0.41	19.82	19.90	21.51	21.52	23.16	27.41	23.40	28.52

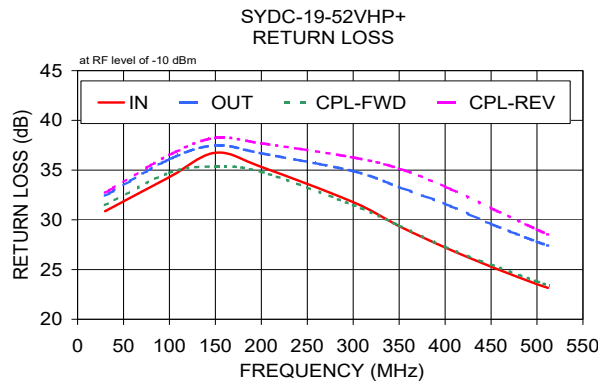
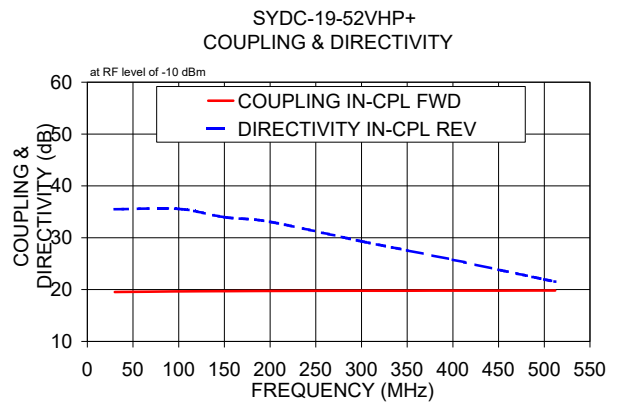
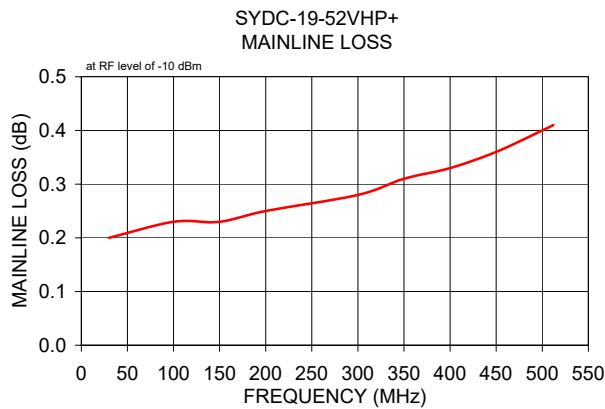

- NOTES**
- A. Performance and quality attributes and conditions not expressly stated in this specification document are intended to be excluded and do not form a part of this specification document.
  - B. Electrical specifications and performance data contained in this specification document are based on Mini-Circuit's applicable established test performance criteria and measurement instructions.
  - C. The parts covered by this specification document are subject to Mini-Circuits standard limited warranty and terms and conditions (collectively, "Standard Terms"); Purchasers of this part are entitled to the rights and benefits contained therein. For a full statement of the standard. Terms and the exclusive rights and remedies thereunder, please visit Mini-Circuits' website at [www.minicircuits.com/terms/viewterm.html](http://www.minicircuits.com/terms/viewterm.html)

