

Frequency Synthesizer

WSN-4G+

50Ω Very Wide Bandwidth 700 to 4000 MHz

The Big Deal

- Very wide bandwidth
- Integrated VCO + PLL
- Fast settling time
- High reliability over temperature changes
- Operating voltage (VCC VCO=+10V, VCC PLL=+22V)
- Size 1.25" x 1.75" x 0.22"



CASE STYLE: KN1368

Product Overview

The WSN-4G+ is a very wide bandwidth Frequency Synthesizer, designed to operate from 700 to 4000 MHz for jammers application. The WSN-4G+ is packaged in a metal case (size of 1.25" x 1.75" x 0.22") to shield against unwanted signals and noise.

Key Features

Feature	Advantages
Very wide bandwidth	Extremely wide frequency range 700 - 4000 MHz. This broadband synthesizer boasts output levels of +8 dBm, typical spurious performance of -80 dBc or better and low phase noise.
Fast settling time	Less than 30 μ sec within 1deg can be used for settling applications such as jammers etc.

Notes

- A. Performance and quality attributes and conditions not expressly stated in this specification document are intended to be excluded and do not form a part of this specification document.
B. Electrical specifications and performance data contained in this specification document are based on Mini-Circuit's applicable established test performance criteria and measurement instructions.
C. The parts covered by this specification document are subject to Mini-Circuits standard limited warranty and terms and conditions (collectively, "Standard Terms"); Purchasers of this part are entitled to the rights and benefits contained therein. For a full statement of the Standard Terms and the exclusive rights and remedies thereunder, please visit Mini-Circuits' website at www.minicircuits.com/MCLStore/terms.jsp



Frequency Synthesizer

50Ω Very Wide Bandwidth 700 to 4000 MHz

Features

- Very wide bandwidth
- Integrated VCO + PLL
- Fast settling time
- High reliability over temperature changes
- Operating voltage (VCC VCO=+10V, VCC PLL=+22V)
- Size 1.25" x 1.75" x 0.22"



CASE STYLE: KN1368

+RoHS Compliant

The +Suffix identifies RoHS Compliance. See our web site for RoHS Compliance methodologies and qualifications

Applications

- Jammers

General Description

The WSN-4G+ is a very wide bandwidth Frequency Synthesizer, designed to operate from 700 to 4000 MHz for jammers application. The WSN-4G+ is packaged in a metal case (size of 1.25" x 1.75" x 0.22") to shield against unwanted signals and noise.

Simplified Schematic

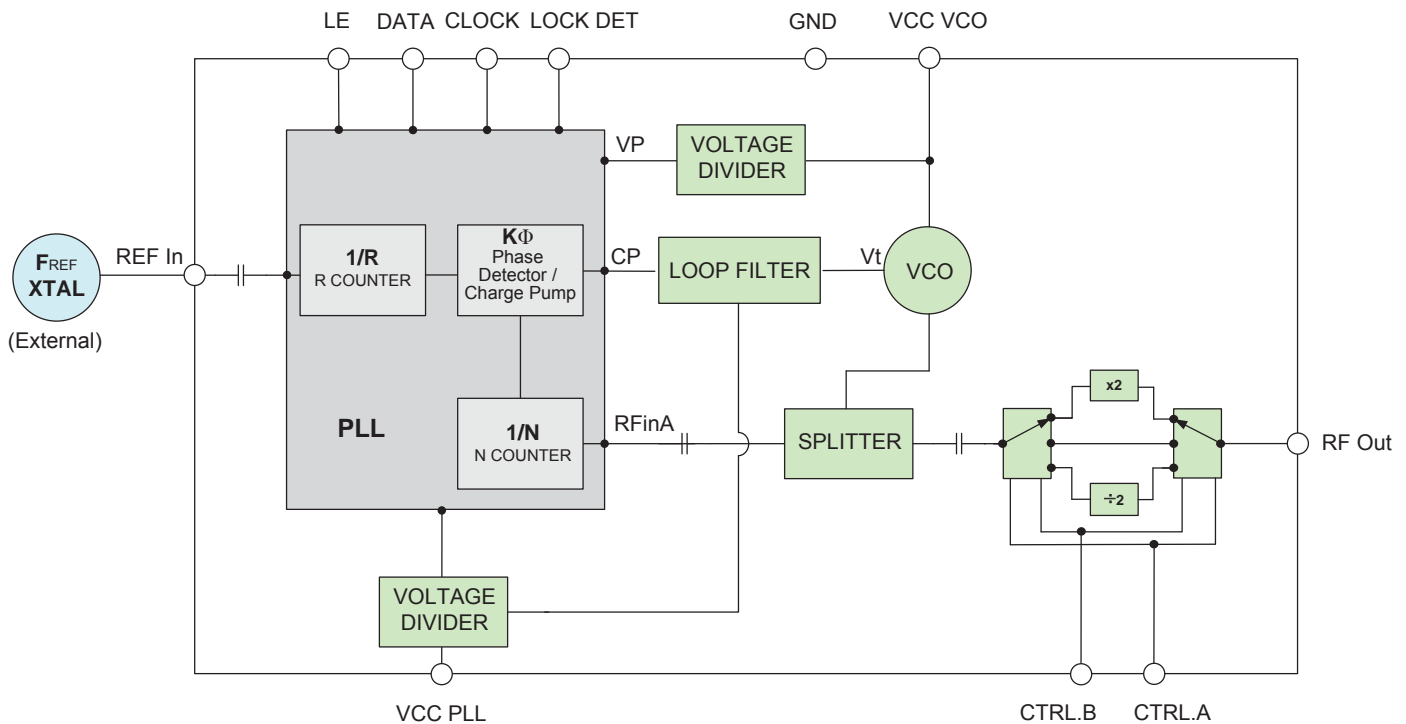

Notes

- A. Performance and quality attributes and conditions not expressly stated in this specification document are intended to be excluded and do not form a part of this specification document.
- B. Electrical specifications and performance data contained in this specification document are based on Mini-Circuits' applicable established test performance criteria and measurement instructions.
- C. The parts covered by this specification document are subject to Mini-Circuits standard limited warranty and terms and conditions (collectively, "Standard Terms"); Purchasers of this part are entitled to the rights and benefits contained therein. For a full statement of the Standard Terms and the exclusive rights and remedies thereunder, please visit Mini-Circuits' website at www.minicircuits.com/MCLStore/terms.jsp

Electrical Specifications (over operating temperature -40°C to +85°C)

Parameters	Test Conditions		Min.	Typ.	Max.	Units
Frequency Range	-		700	-	4000	MHz
Step Size	-		-	10	-	MHz
Comparison Frequency	-		-	5	-	MHz
Settling Time within bands	Within ±1deg. for any 10MHz step	@ 700 to 1110 MHz	-	15	30	μSec
		@ 1120 to 2220 MHz				
		@ 2230 to 4000 MHz				
Output Power	-		+5	+8	+11	dBm
SSB Phase Noise	@ 100 Hz	@ 700 to 1110 MHz	-	-93	-	dBc / Hz
		@ 1120 to 2220 MHz	-	-88	-	
		@ 2230 to 4000 MHz	-	-83	-	
	@ 1 kHz offset	@ 700 to 1110 MHz	-	-106	-98	
		@ 1120 to 2220 MHz	-	-101	-92	
		@ 2230 to 4000 MHz	-	-95	-87	
	@ 10 kHz offset	@ 700 to 1110 MHz	-	-107	-100	
		@ 1120 to 2220 MHz	-	-102	-95	
		@ 2230 to 4000 MHz	-	-97	-90	
	@ 100 kHz offset	@ 700 to 1110 MHz	-	-104	-96	
		@ 1120 to 2220 MHz	-	-100	-90	
		@ 2230 to 4000 MHz	-	-94	-87	
@ 1 MHz offset	@ 700 to 1110 MHz	-	-127	-119		
	@ 1120 to 2220 MHz	-	-121	-114		
	@ 2230 to 4000 MHz	-	-115	-108		
Reference Spurious Suppression	Ref. Freq. 20 MHz	@ 700 to 1110 MHz	-	-97	-75	dBc
		@ 1120 to 2220 MHz	-	-100	-75	
		@ 2230 to 4000 MHz	-	-95	-75	
Comparison Spurious Suppression	Comp. Freq. 5 MHz	@ 700 to 1110 MHz	-	-89	-70	
		@ 1120 to 2220 MHz	-	-81	-64	
		@ 2230 to 4000 MHz	-	-86	-70	
Non - Harmonic Spurious Suppression		-	-	-90	-	
Harmonic Suppression		-	-	-33	-10	
VCO Power Supply		-	+9.75	+10.00	+10.25	
PLL Power Supply		-	+21.75	+22.00	+22.25	V
VCO Supply Current		-	-	140	220	mA
PLL Supply Current		-	-	16	25	mA
Reference Input (External)	Frequency	Square wave	-	20	-	MHz
	Amplitude	-	-	1	-	V _{p-p}
	Input impedance	-	-	100	-	KΩ
	Phase. Noise @ 1 kHz offset	-	-	-145	-	dBc/Hz
RF Output port Impedance		-	-	50	-	Ω
Input Logic Level	Input high voltage	-	2.80	-	-	V
	Input low voltage	-	-	-	0.60	V
Digital Lock Detect	Locked	-	2.75	-	3.40	V
	Unlocked	-	-	-	0.40	V
Input Logic Level for Control A & Control B	Input high voltage	-	3.50	-	-	V
	Input low voltage	-	-	-	0.50	V

Notes

- A. Performance and quality attributes and conditions not expressly stated in this specification document are intended to be excluded and do not form a part of this specification document.
- B. Electrical specifications and performance data contained in this specification document are based on Mini-Circuit's applicable established test performance criteria and measurement instructions.
- C. The parts covered by this specification document are subject to Mini-Circuits standard limited warranty and terms and conditions (collectively, "Standard Terms"); Purchasers of this part are entitled to the rights and benefits contained therein. For a full statement of the Standard Terms and the exclusive rights and remedies thereunder, please visit Mini-Circuits' website at www.minicircuits.com/MCLStore/terms.jsp



Electrical Specifications (over operating temperature -40°C to +85°C) (continued)

Frequency Synthesizer PLL		ADF4106												
PLL Programming		3-wire serial 3V CMOS												
Register Map <small>NOTE 3,4</small>	F_Register*	<i>Prescaler Value</i>	<i>Power-Down 2</i>	<i>Current Setting 2*</i>	<i>Current Setting 1</i>	<i>Timer Counter Control</i>	<i>Fastlock Mode</i>	<i>Fastlock Enable</i>	<i>CP 3-State</i>	<i>PD Polarity</i>	<i>Muxout Control</i>	<i>Power-Down 1</i>	<i>Counter Reset</i>	<i>Control Bits</i>
		00	0	XYZ	000	0000	0	0	0	0	001	0	0	10
	N_Register	@ 1110 MHz	<i>Reserved</i>	<i>CP Gain</i>	<i>13-Bit B Counter</i>						<i>6-Bit A Counter</i>			<i>Control Bits</i>
		@ 1580 MHz	00	1	0000000110111						000100			01
		@ 4000 MHz	00	1	0000000100111						000100			01
	R_Register		<i>Reserved</i>	<i>Lock Detect Precision</i>	<i>Test Mode Bits</i>	<i>Anti-Blacklash Width</i>	<i>14-BIT Reference Counter</i>						<i>Control Bits</i>	
		000	1	00	00	00000000000100						00		

*** Refer to Charge Pump Settings**

Band	Freq. Range [MHz]	X	Y	Z
#1	700-920	0	1	1
	930-1020	1	0	0
	1030-1040	1	0	1
	1050-1070	1	1	0
	1080-1110	1	1	1
#2	1120-1150	0	0	1
	1160-1270	0	1	0
	1280-1840	0	1	1
	1850-2040	1	0	0
	2050-2090	1	0	1
	2100-2150	1	1	0
	2160-2220	1	1	1
#3	2230-2300	0	0	1
	2310-2540	0	1	0
	2550-3680	0	1	1
	3690-4000	1	0	0

Note 1: For frequencies in the 700-1100MHz range the N Register should be programmed to a frequency which is twice the desired output frequency.
Note 2: For frequencies in the 2230-4000MHz range the N Register should be programmed to a frequency which is half the desired output frequency.
Note 3: Registers Load Sequence: Initialization Register, F Register, R Register, N Register.
Note 4: For the Initialization Register use Register F with Control Bits 11.

Frequency Bands Function

Frequency Out [MHz]	Control	
	CTRL.A (PIN # 8)	CTRL.B (PIN # 7)
700-1110	0	1
1120-2220	1	0
2230-4000	0	0
N.A	1	1

Absolute Maximum Ratings

Parameters	Ratings
VCO Supply Voltage	+12V
PLL Supply Voltage	+24V
VCO Power Supply to PLL Power Supply	Note 5
Reference Frequency Amplitude	3.6V _{p-p}
Data, Clock, LE Levels	-0.3Vmin, +3.6Vmax
Control A & Control B Levels	-0.3Vmin, +5.0Vmax
Operating Temperature	-40°C to +85°C
Storage Temperature	-55°C to +100°C

Note 5: Power on/off Sequence: Power on: VCO Supply Voltage, followed by PLL Supply Voltage. Power off: PLL Supply Voltage, followed by VCO Supply Voltage.

Permanent damage may occur if any of these limits are exceeded

Notes

A. Performance and quality attributes and conditions not expressly stated in this specification document are intended to be excluded and do not form a part of this specification document.
 B. Electrical specifications and performance data contained in this specification document are based on Mini-Circuit's applicable established test performance criteria and measurement instructions.
 C. The parts covered by this specification document are subject to Mini-Circuits standard limited warranty and terms and conditions (collectively, "Standard Terms"); Purchasers of this part are entitled to the rights and benefits contained therein. For a full statement of the Standard Terms and the exclusive rights and remedies thereunder, please visit Mini-Circuits' website at www.minicircuits.com/MCLStore/terms.jsp



Typical Performance Data

FREQUENCY (MHz)	POWER OUTPUT (dBm)			VCO CURRENT (mA)			PLL CURENT (mA)		
	-45°C	+25°C	+85°C	-45°C	+25°C	+85°C	-45°C	+25°C	+85°C
700	8.45	8.53	8.37	116.97	120.03	123.15	15.48	16.91	17.88
780	8.38	8.41	8.08	117.24	120.31	123.36	15.61	17.05	18.02
860	8.31	8.21	7.77	117.49	120.55	123.61	15.75	17.18	18.15
940	8.46	8.24	7.55	117.77	120.86	123.96	15.88	17.32	18.29
1020	8.44	8.16	7.19	118.04	121.15	124.27	16.01	17.46	18.42
1100	8.29	7.98	6.79	118.16	121.32	124.55	16.14	17.59	18.55
1110	8.25	7.95	6.76	118.15	121.33	124.56	16.24	17.69	18.65
1120	8.93	8.52	8.11	106.32	108.99	111.62	15.26	16.71	17.67
1260	8.97	8.62	8.33	107.35	109.92	112.37	15.44	16.90	17.86
1420	8.08	7.98	7.74	107.89	110.45	112.85	15.57	17.04	18.00
1580	7.57	7.50	7.29	108.01	110.57	112.97	15.71	17.18	18.13
1740	7.25	7.34	7.20	108.06	110.59	113.02	15.84	17.32	18.27
1820	7.58	7.53	7.38	108.07	110.61	113.08	15.91	17.38	18.34
2220	8.36	8.12	7.48	108.59	111.41	114.13	16.24	17.72	18.71
2230	7.68	7.83	7.77	151.86	157.66	164.47	15.37	16.85	17.85
2380	6.99	7.45	7.47	155.05	160.35	166.63	15.41	16.91	17.90
2540	6.82	7.18	7.34	159.62	164.68	170.62	15.48	16.98	17.97
2780	8.61	8.23	7.93	165.64	170.67	176.20	15.58	17.09	18.08
3180	9.98	9.20	8.61	170.24	175.81	181.85	15.74	17.26	18.25
3420	9.51	8.90	8.35	171.66	177.40	183.62	15.85	17.37	18.36
4000	7.42	6.77	6.31	170.07	176.42	183.25	15.99	17.51	18.50

Notes

- A. Performance and quality attributes and conditions not expressly stated in this specification document are intended to be excluded and do not form a part of this specification document.
- B. Electrical specifications and performance data contained in this specification document are based on Mini-Circuits' applicable established test performance criteria and measurement instructions.
- C. The parts covered by this specification document are subject to Mini-Circuits standard limited warranty and terms and conditions (collectively, "Standard Terms"); Purchasers of this part are entitled to the rights and benefits contained therein. For a full statement of the Standard Terms and the exclusive rights and remedies thereunder, please visit Mini-Circuits' website at www.minicircuits.com/MCLStore/terms.jsp



FREQUENCY (MHz)	HARMONICS (dBc)								
	F0.5			F1.5			F2.5		
	-45°C	+25°C	+85°C	-45°C	+25°C	+85°C	-45°C	+25°C	+85°C
2230	-54.35	-53.86	-54.03	-33.31	-25.02	-17.95	-37.57	-34.51	-31.80
2380	-47.00	-47.10	-48.10	-28.75	-25.24	-21.30	-38.48	-51.42	-44.78
2540	-41.13	-42.00	-43.30	-16.71	-16.94	-17.70	-36.25	-41.77	-44.63
2780	-36.25	-38.22	-38.85	-14.24	-16.60	-18.66	-36.33	-37.93	-40.87
3180	-29.74	-31.90	-31.17	-28.17	-28.33	-26.85	-51.45	-48.08	-47.25
3420	-25.75	-27.36	-25.97	-30.33	-28.06	-27.42	-63.03	-60.80	-61.72
4000	-22.97	-21.18	-17.62	-29.00	-28.66	-32.07	-54.15	-56.10	-59.87

FREQUENCY (MHz)	HARMONICS (dBc)					
	F2			F3		
	-45°C	+25°C	+85°C	-45°C	+25°C	+85°C
700	-15.31	-15.61	-14.89	-46.71	-48.29	-48.98
780	-21.96	-22.65	-22.81	-59.03	-62.05	-61.56
860	-36.41	-38.71	-40.30	-54.84	-54.55	-56.44
940	-41.79	-43.34	-45.36	-54.17	-55.26	-56.83
1020	-43.56	-44.65	-47.20	-54.39	-57.80	-59.07
1100	-49.47	-54.33	-56.02	-56.85	-59.35	-59.05
1110	-50.99	-53.61	-55.52	-57.57	-60.62	-59.03
1120	-14.80	-22.47	-24.64	-33.16	-35.49	-35.62
1260	-16.73	-26.38	-23.30	-55.98	-56.29	-61.23
1420	-24.11	-28.20	-23.51	-53.06	-53.28	-54.18
1580	-28.02	-29.59	-26.76	-55.96	-58.28	-54.84
1740	-35.77	-38.39	-37.22	-50.94	-51.90	-50.65
1820	-43.92	-47.83	-48.19	-52.83	-53.32	-52.60
2220	-52.64	-51.50	-49.01	-50.65	-54.10	-58.25
2230	-17.43	-18.89	-19.79	-37.67	-40.59	-46.32
2380	-21.78	-24.65	-26.06	-40.40	-45.94	-53.66
2540	-24.10	-28.59	-33.55	-40.63	-43.82	-47.47
2780	-25.56	-38.14	-34.02	-47.93	-48.91	-47.44
3180	-30.69	-29.49	-29.71	-45.37	-44.83	-45.69
3420	-36.60	-34.13	-34.87	-55.55	-54.82	-55.78
4000	-38.43	-38.60	-40.15	-56.79	-54.46	-52.39

Notes

- A. Performance and quality attributes and conditions not expressly stated in this specification document are intended to be excluded and do not form a part of this specification document.
- B. Electrical specifications and performance data contained in this specification document are based on Mini-Circuit's applicable established test performance criteria and measurement instructions.
- C. The parts covered by this specification document are subject to Mini-Circuits standard limited warranty and terms and conditions (collectively, "Standard Terms"); Purchasers of this part are entitled to the rights and benefits contained therein. For a full statement of the Standard Terms and the exclusive rights and remedies thereunder, please visit Mini-Circuits' website at www.minicircuits.com/MCLStore/terms.jsp



FREQUENCY (MHz)	PHASE NOISE (dBc/Hz) @OFFSETS				
	+25°C				
	100Hz	1kHz	10kHz	100kHz	1MHz
700	-95.47	-111.53	-110.41	-107.56	-128.68
780	-97.38	-107.46	-109.13	-105.84	-128.38
860	-92.08	-105.74	-107.36	-104.55	-128.60
940	-93.79	-104.82	-108.09	-105.43	-126.54
1020	-94.92	-106.65	-107.10	-103.92	-128.51
1100	-93.83	-103.50	-106.06	-102.79	-128.85
1110	-91.42	-104.57	-105.91	-102.18	-129.76
1120	-92.45	-103.99	-105.74	-101.33	-125.33
1260	-94.85	-106.20	-105.65	-102.19	-124.11
1420	-91.79	-103.04	-103.89	-101.12	-122.42
1580	-91.94	-100.69	-102.27	-99.35	-122.22
1740	-88.67	-101.26	-101.70	-98.57	-122.42
1820	-87.70	-100.11	-101.71	-98.70	-122.70
2220	-86.86	-100.58	-100.59	-96.52	-123.83
2230	-85.71	-97.63	-100.10	-95.67	-119.44
2380	-90.99	-96.32	-100.50	-97.02	-117.96
2540	-86.53	-96.66	-98.63	-95.30	-117.47
2780	-86.55	-94.07	-97.32	-94.97	-116.01
3180	-85.45	-94.77	-95.63	-92.76	-115.85
3420	-83.77	-95.01	-95.77	-92.46	-116.15
4000	-84.17	-94.85	-95.31	-92.16	-115.77

FREQUENCY (MHz)	PHASE NOISE (dBc/Hz) @OFFSETS				
	-45°C				
	100Hz	1kHz	10kHz	100kHz	1MHz
700	-86.70	-106.41	-108.63	-105.97	-127.91
780	-85.53	-104.53	-107.50	-104.35	-128.02
860	-87.41	-104.58	-106.54	-102.35	-128.20
940	-85.54	-105.25	-105.51	-103.28	-126.04
1020	-83.21	-103.36	-105.11	-102.56	-127.35
1100	-83.16	-102.78	-105.26	-102.21	-127.59
1110	-85.33	-103.51	-105.43	-102.03	-128.35
1120	-84.57	-102.15	-104.82	-100.48	-125.86
1260	-83.46	-101.66	-104.70	-101.37	-123.55
1420	-84.15	-99.91	-103.33	-100.46	-122.31
1580	-82.04	-100.89	-101.76	-98.41	-122.36
1740	-84.14	-98.43	-100.20	-96.57	-122.63
1820	-78.27	-98.91	-99.79	-96.23	-122.30
2220	-79.95	-96.83	-98.76	-95.91	-122.29
2230	-79.16	-96.68	-99.30	-94.82	-119.83
2380	-77.19	-95.62	-99.04	-96.56	-118.10
2540	-77.63	-94.88	-97.49	-94.20	-116.72
2780	-77.94	-96.83	-96.27	-93.44	-115.23
3180	-76.11	-91.53	-95.51	-91.59	-115.73
3420	-74.37	-92.54	-94.50	-90.58	-116.42
4000	-73.50	-91.69	-94.42	-91.75	-115.40

FREQUENCY (MHz)	PHASE NOISE (dBc/Hz) @OFFSETS				
	+85°C				
	100Hz	1kHz	10kHz	100kHz	1MHz
700	-93.07	-105.42	-108.73	-106.14	-127.66
780	-90.86	-106.23	-107.68	-104.77	-127.38
860	-91.27	-106.13	-107.56	-104.29	-126.87
940	-90.26	-104.32	-106.89	-104.55	-124.73
1020	-89.73	-105.47	-106.19	-102.53	-127.26
1100	-86.71	-102.82	-104.23	-100.56	-128.54
1110	-89.80	-102.34	-104.37	-99.99	-129.35
1120	-89.72	-102.53	-105.14	-100.41	-124.38
1260	-90.62	-102.37	-104.15	-100.64	-123.13
1420	-86.13	-101.18	-102.08	-99.75	-121.40
1580	-84.47	-100.28	-101.73	-98.55	-121.07
1740	-84.81	-101.37	-101.35	-98.26	-120.83
1820	-86.44	-98.52	-100.89	-98.12	-120.90
2220	-80.50	-94.69	-98.10	-94.20	-123.53
2230	-82.34	-95.50	-99.28	-94.70	-118.41
2380	-82.32	-96.67	-98.32	-95.29	-116.88
2540	-78.68	-96.60	-97.00	-93.60	-116.47
2780	-79.11	-96.20	-96.67	-93.54	-114.89
3180	-81.25	-95.15	-95.29	-91.77	-114.64
3420	-81.12	-97.37	-95.47	-92.59	-114.95
4000	-76.13	-91.55	-94.36	-91.11	-114.90

Notes

- A. Performance and quality attributes and conditions not expressly stated in this specification document are intended to be excluded and do not form a part of this specification document.
- B. Electrical specifications and performance data contained in this specification document are based on Mini-Circuits' applicable established test performance criteria and measurement instructions.
- C. The parts covered by this specification document are subject to Mini-Circuits standard limited warranty and terms and conditions (collectively, "Standard Terms"); Purchasers of this part are entitled to the rights and benefits contained therein. For a full statement of the Standard Terms and the exclusive rights and remedies thereunder, please visit Mini-Circuits' website at www.minicircuits.com/MCLStore/terms.jsp



COMPARISON SPURIOUS ORDER	COMPARISON SPURIOUS @Fcarrier 910MHz+(0.5n*Fcomparison) (dBc) note 1			COMPARISON SPURIOUS @Fcarrier 1670MHz+(n*Fcomparison) (dBc) note 1			COMPARISON SPURIOUS @Fcarrier 3120MHz+(2n*Fcomparison) (dBc) note 1		
	n	-45°C	+25°C	+85°C	-45°C	+25°C	+85°C	-45°C	+25°C
-5	-124.00	-123.54	-122.01	-105.92	-110.03	-105.95	-106.89	-101.36	-102.07
-4	-101.00	-96.46	-97.93	-105.20	-110.59	-105.95	-107.73	-97.23	-96.08
-3	-122.66	-124.00	-122.69	-101.18	-104.41	-99.56	-103.55	-97.18	-113.91
-2	-81.76	-80.26	-80.66	-91.46	-92.44	-90.97	-106.21	-96.23	-113.88
-1	-121.40	-119.95	-120.98	-75.10	-74.20	-73.53	-85.54	-85.00	-84.92
0 note 2	-	-	-	-	-	-	-	-	-
+1	-120.35	-121.50	-120.51	-74.98	-73.91	-73.35	-85.91	-84.75	-85.05
+2	-81.74	-80.46	-80.38	-91.70	-90.83	-89.87	-107.45	-94.34	-114.09
+3	-124.27	-122.75	-123.25	-99.16	-100.98	-98.53	-108.67	-96.76	-109.56
+4	-102.12	-97.93	-96.83	-102.37	-104.52	-102.57	-94.99	-92.30	-90.86
+5	-125.38	-123.26	-122.62	-103.31	-105.41	-103.86	-104.58	-101.55	-102.15

Note 1: Comparison frequency 5 MHz

Note 2: All spurs are referenced to carrier signal (n=0).

REFERENCE SPURIOUS ORDER	REFERENCE SPURIOUS @Fcarrier 910MHz+(0.5n*Freference) (dBc) note 3			REFERENCE SPURIOUS @Fcarrier 1670MHz+(n*Freference) (dBc) note 3			REFERENCE SPURIOUS @Fcarrier 3120MHz+(2n*Freference) (dBc) note 3		
	n	-45°C	+25°C	+85°C	-45°C	+25°C	+85°C	-45°C	+25°C
-5	-114.92	-113.35	-108.20	-105.31	-121.47	-108.83	-93.78	-95.21	-93.48
-4	-111.00	-109.32	-101.53	-109.68	-114.65	-110.09	-110.20	-97.20	-109.63
-3	-111.70	-122.88	-109.38	-107.53	-118.66	-112.84	-102.98	-97.93	-100.61
-2	-111.47	-112.23	-102.41	-113.75	-101.30	-99.17	-106.90	-101.56	-100.68
-1	-101.25	-97.27	-97.72	-104.98	-109.55	-105.68	-107.59	-97.38	-96.27
0 note 4	-	-	-	-	-	-	-	-	-
+1	-102.77	-98.42	-97.99	-102.38	-106.31	-102.80	-95.14	-92.33	-90.94
+2	-111.65	-117.97	-105.00	-103.56	-103.07	-97.38	-108.59	-103.21	-102.84
+3	-112.00	-114.45	-109.13	-111.62	-117.57	-116.41	-103.69	-98.91	-102.11
+4	-107.46	-106.73	-102.90	-110.99	-114.06	-111.12	-113.05	-98.64	-112.86
+5	-110.59	-109.59	-108.23	-105.66	-113.97	-114.46	-94.67	-96.00	-94.53

Note 3: Reference frequency 20 MHz

Note 4: All spurs are referenced to carrier signal (n=0).

Notes

- A. Performance and quality attributes and conditions not expressly stated in this specification document are intended to be excluded and do not form a part of this specification document.
- B. Electrical specifications and performance data contained in this specification document are based on Mini-Circuits' applicable established test performance criteria and measurement instructions.
- C. The parts covered by this specification document are subject to Mini-Circuits standard limited warranty and terms and conditions (collectively, "Standard Terms"); Purchasers of this part are entitled to the rights and benefits contained therein. For a full statement of the Standard Terms and the exclusive rights and remedies thereunder, please visit Mini-Circuits' website at www.minicircuits.com/MCLStore/terms.jsp



Typical Performance Curves

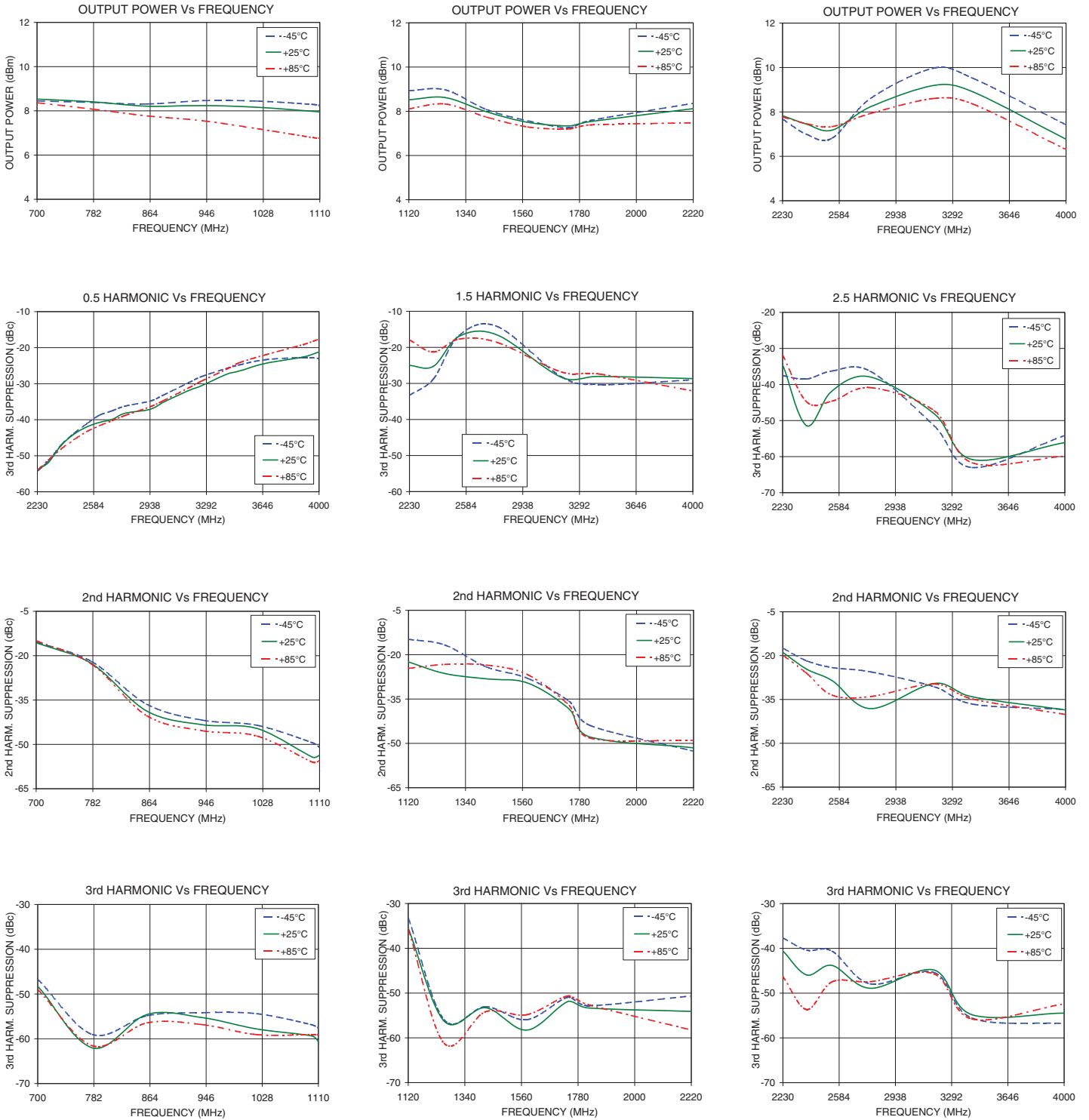

Notes

- A. Performance and quality attributes and conditions not expressly stated in this specification document are intended to be excluded and do not form a part of this specification document.
- B. Electrical specifications and performance data contained in this specification document are based on Mini-Circuits' applicable established test performance criteria and measurement instructions.
- C. The parts covered by this specification document are subject to Mini-Circuits standard limited warranty and terms and conditions (collectively, "Standard Terms"); Purchasers of this part are entitled to the rights and benefits contained therein. For a full statement of the Standard Terms and the exclusive rights and remedies thereunder, please visit Mini-Circuits' website at www.minicircuits.com/MCLStore/terms.jsp



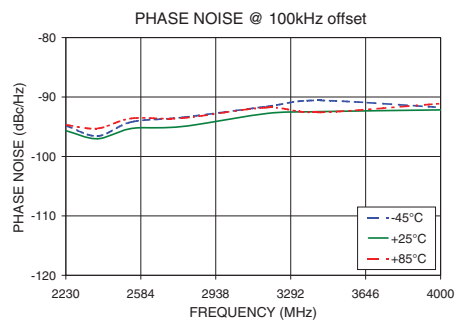
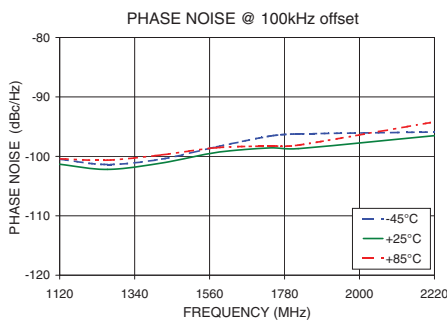
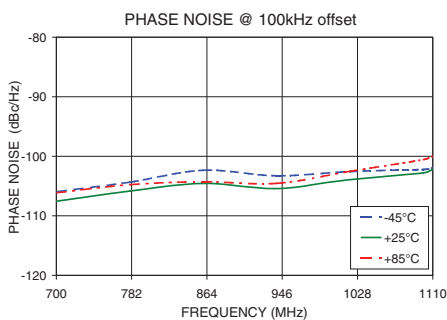
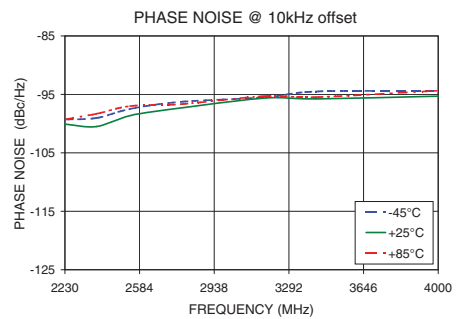
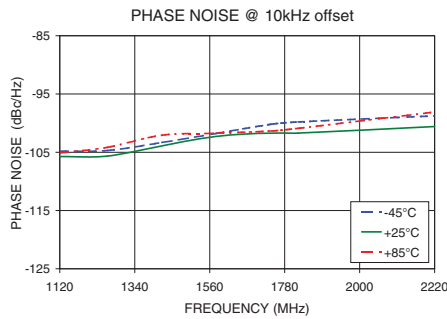
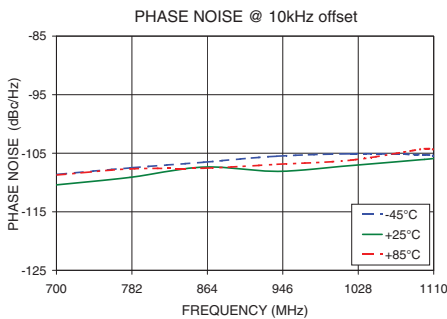
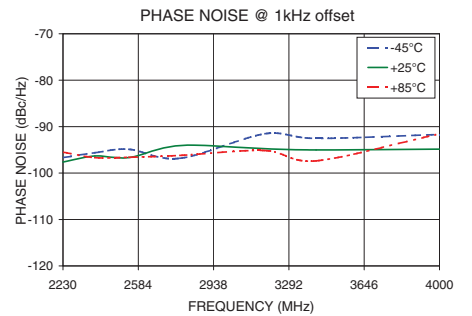
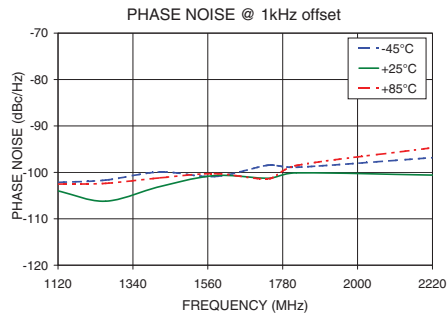
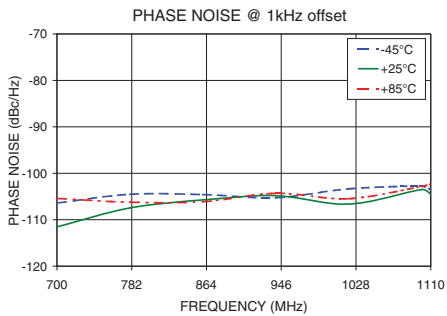
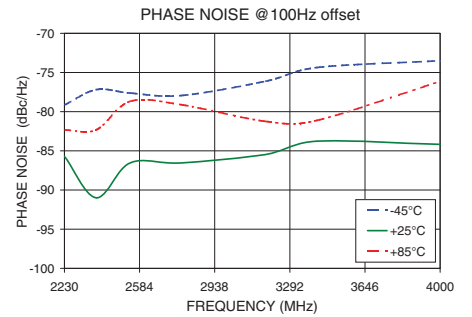
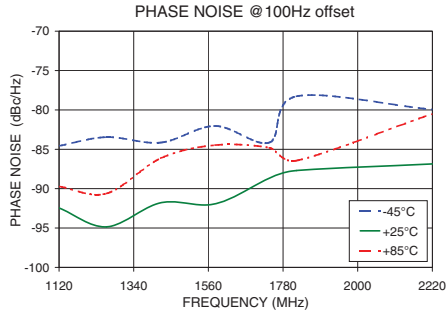
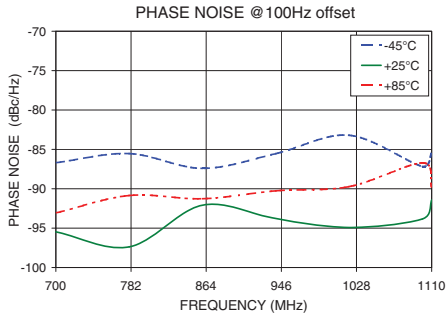

Notes

- A. Performance and quality attributes and conditions not expressly stated in this specification document are intended to be excluded and do not form a part of this specification document.
- B. Electrical specifications and performance data contained in this specification document are based on Mini-Circuits' applicable established test performance criteria and measurement instructions.
- C. The parts covered by this specification document are subject to Mini-Circuits standard limited warranty and terms and conditions (collectively, "Standard Terms"); Purchasers of this part are entitled to the rights and benefits contained therein. For a full statement of the Standard Terms and the exclusive rights and remedies thereunder, please visit Mini-Circuits' website at www.minicircuits.com/MCLStore/terms.jsp



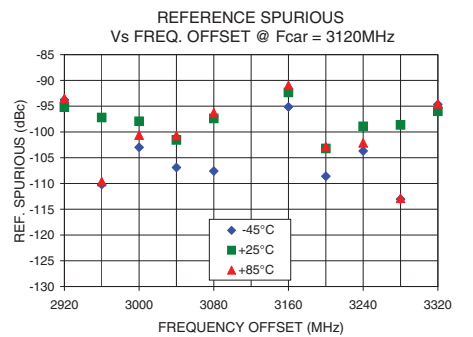
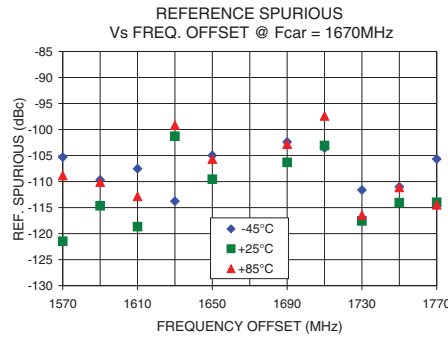
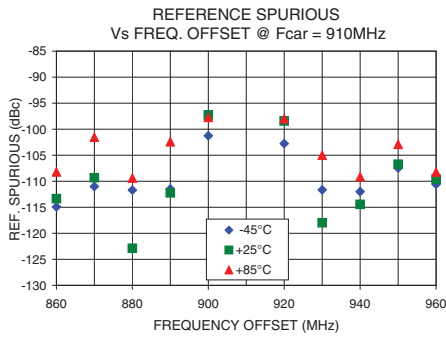
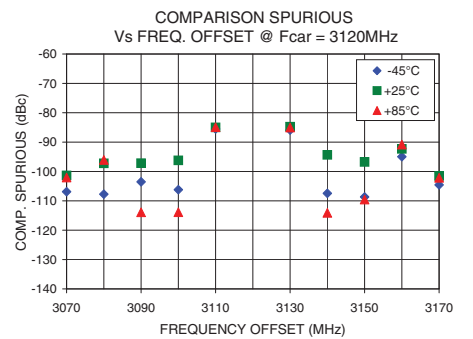
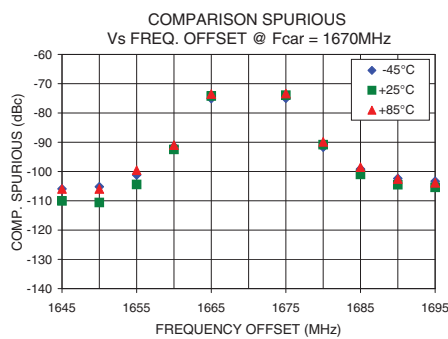
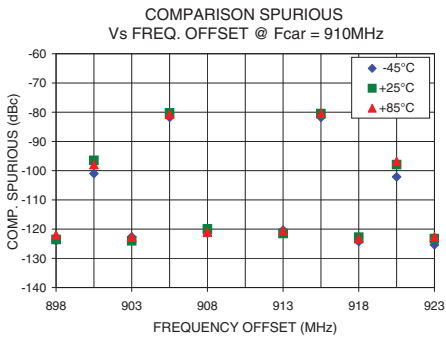
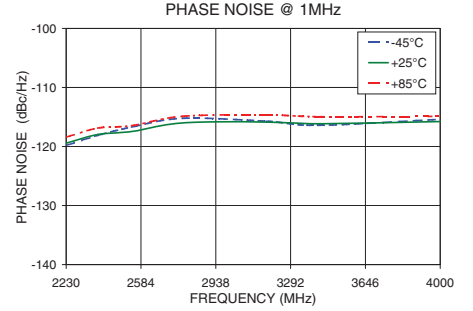
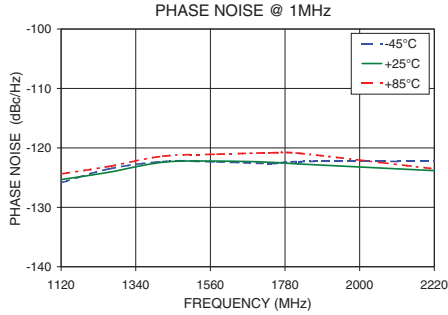
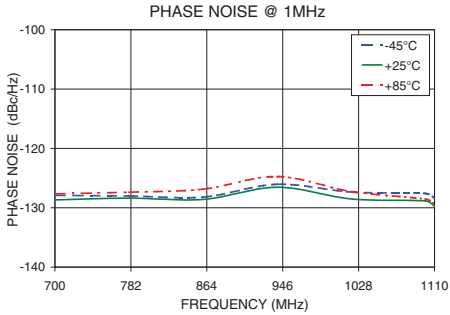

Notes

- A. Performance and quality attributes and conditions not expressly stated in this specification document are intended to be excluded and do not form a part of this specification document.
- B. Electrical specifications and performance data contained in this specification document are based on Mini-Circuit's applicable established test performance criteria and measurement instructions.
- C. The parts covered by this specification document are subject to Mini-Circuit's standard limited warranty and terms and conditions (collectively, "Standard Terms"); Purchasers of this part are entitled to the rights and benefits contained therein. For a full statement of the Standard Terms and the exclusive rights and remedies thereunder, please visit Mini-Circuit's website at www.minicircuits.com/MCLStore/terms.jsp



Pin Configuration

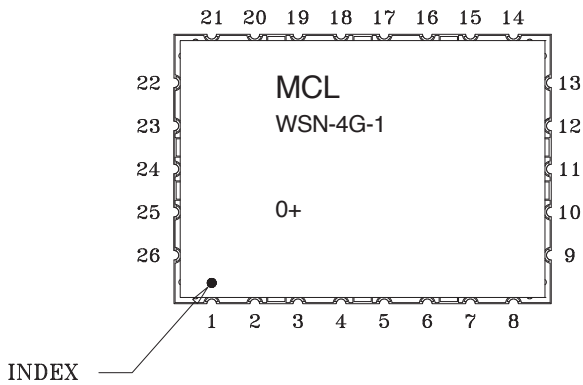

Pin Connection

Pin Number	Function	Pin Number	Function	Pin Number	Function
1	GND	10	VCC VCO	19	GND
2	CLOCK	11	GND	20	GND
3	DATA	12	GND	21	GND
4	LE	13	RF OUT	22	GND
5	LOCK DET	14	GND	23	GND
6	VCC PLL	15	GND	24	GND
7	CTRL.B	16	GND	25	REF IN
8	CTRL.A	17	GND	26	GND
9	GND	18	GND		

Recommended Application Circuit

Note: REF IN and RF OUT ports are internally AC coupled.

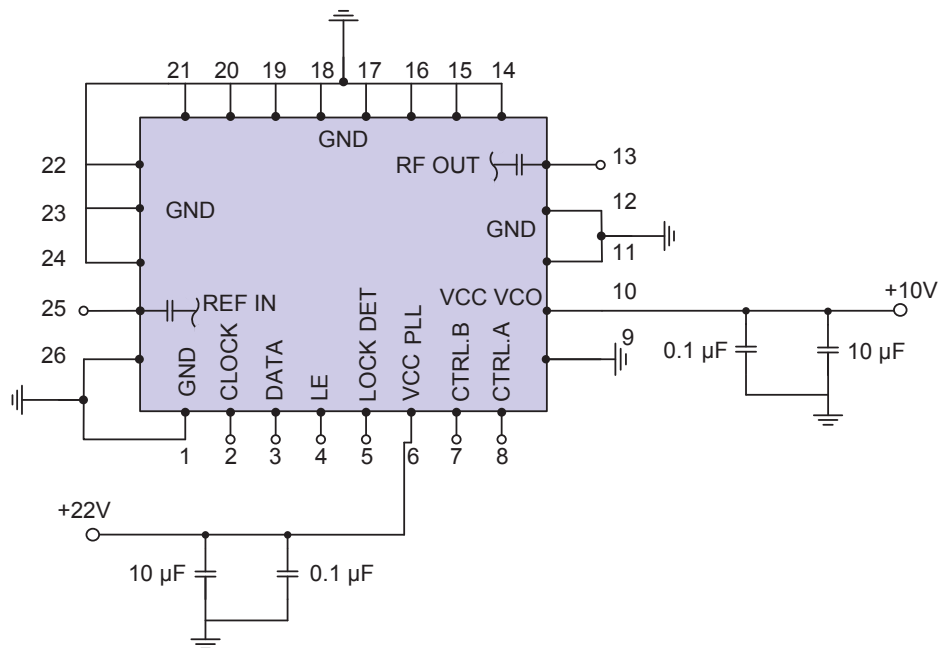

Notes

- A. Performance and quality attributes and conditions not expressly stated in this specification document are intended to be excluded and do not form a part of this specification document.
- B. Electrical specifications and performance data contained in this specification document are based on Mini-Circuits' applicable established test performance criteria and measurement instructions.
- C. The parts covered by this specification document are subject to Mini-Circuits standard limited warranty and terms and conditions (collectively, "Standard Terms"); Purchasers of this part are entitled to the rights and benefits contained therein. For a full statement of the Standard Terms and the exclusive rights and remedies thereunder, please visit Mini-Circuits' website at www.minicircuits.com/MCLStore/terms.jsp



Device Marking

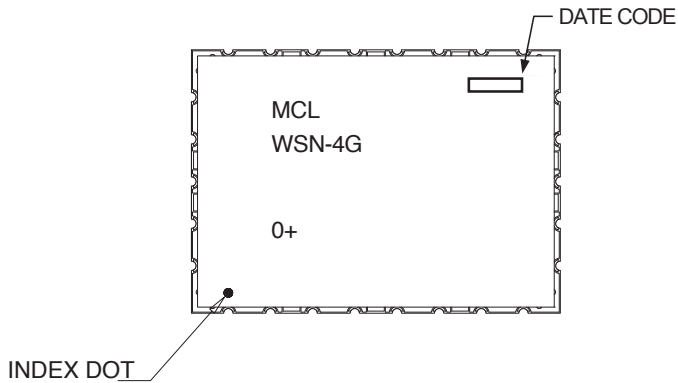

Additional Detailed Technical Information

Additional information is available on our web site. To access this information enter the model number on our web site home page.

Case Style: KN1368

Tape & Reel: TR-F96

Suggested Layout for PCB Design: PL-326

Evaluation Board: TB-572+

Environment Ratings: ENV65T2

Synthesizer evaluation software to set PLL registers manually is available at http://www.minicircuits.com/support/software_download.html

Notes

- A. Performance and quality attributes and conditions not expressly stated in this specification document are intended to be excluded and do not form a part of this specification document.
- B. Electrical specifications and performance data contained in this specification document are based on Mini-Circuit's applicable established test performance criteria and measurement instructions.
- C. The parts covered by this specification document are subject to Mini-Circuits standard limited warranty and terms and conditions (collectively, "Standard Terms"); Purchasers of this part are entitled to the rights and benefits contained therein. For a full statement of the Standard Terms and the exclusive rights and remedies thereunder, please visit Mini-Circuits' website at www.minicircuits.com/MCLStore/terms.jsp

