

Coaxial High Power Amplifier

ZHL-100W-242+

50Ω 100W 2000 to 2400 MHz

Features

- saturated power 100W typ.
- wide bandwidth, usable 1900 to 2450 MHz
- high gain, 50 dB typ.
- good gain flatness, ± 1.0 dB typ.
- unconditionally stable
- self protected against excessive drive, high case temp., reverse polarity and shorting/unshorting
- can withstand short and open circuit at output while delivering 100 watts

Applications

- high power test sets
- burn-in set-ups
- communications
- radar



Generic photo used for illustration purposes only

Model No.	ZHL-100W-242+
Case Style	BT1689
Connectors	IN-SMA, OUT-N-Type

+RoHS Compliant

The +Suffix identifies RoHS Compliance. See our web site for RoHS Compliance methodologies and qualifications

Electrical Specifications at 25°C

Parameter	Condition (MHz)	ZHL-100W-242+			Units
		Min.	Typ.	Max.	
Frequency Range		2000	—	2400	MHz
Gain ¹	2000-2400	45	50	55	dB
Gain Flatness ¹	2000-2400	—	± 1.0	± 1.7	dB
Output Power at 1dB compression	2000-2400	+48	+49.5	—	dBm
Output Power at 3dB compression	2000-2400	+48.5	+50	—	dBm
Noise Figure	2000-2400	—	7.8	10	dB
Output third order intercept point ²	2000-2400	+53	+55	—	dBm
Input VSWR ¹	2000-2400	—	1.65	2.1	:1
Output VSWR ¹	2000-2400	—	1.25	2.0	:1
DC Supply Voltage		—	28 ⁴	30	V
Supply Current ³		—	11	12	A

1. Small signal input power -15 dBm typ.

2. Two tones, 40 dBm/tone, 1 MHz spacing.

3. Power supply should be capable of delivering 14A at start up;

11 A current measurement at 100 W output.

4. Recommended Operating Voltage.

Maximum Ratings

Parameter	Ratings
Operating Temperature	-20°C to 45°C
Storage Temperature	-55°C to 100°C
DC Voltage	30V
Input RF Power (no damage)	+7 dBm

Permanent damage may occur if any of these limits are exceeded.

Outline Drawing for models with heatsink

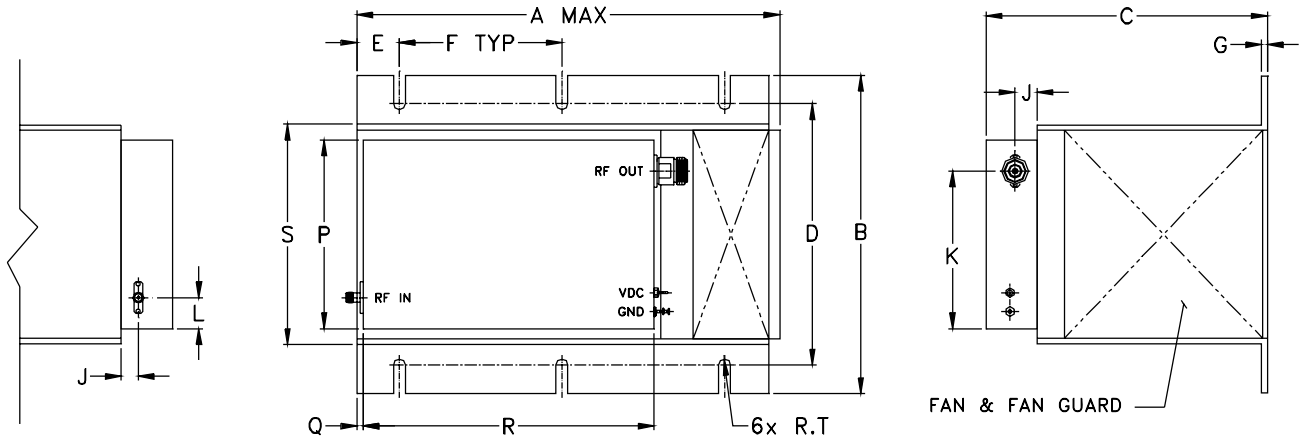

Outline Dimensions ($\frac{\text{inch}}{\text{mm}}$)

A	B	C	D	E	F	G	J	K	L	P	Q	R	S	T	wt
9.85	7.3	6.5	6.00	.98	3.75	.13	.51	3.62	.72	4.33	.2	6.69	5.1	.136	grams
250.19	185.42	165.10	152.40	24.89	95.25	3.30	12.95	91.95	18.29	109.98	5.08	169.93	129.54	3.45	4565

FREQUENCY (MHz)	GAIN (dB)	DIRECTIVITY (dB)	VSWR (:1)		POUT at 1 dB COMPR. (dBm)	NOISE FIGURE (dB)	OIP3 (dBm)
	28V	28V	IN	OUT	28V	28V	28V
2000	49.11	53.64	1.85	1.18	50.97	7.97	55.06
2060	49.62	37.81	1.72	1.23	50.76	7.88	56.72
2100	49.69	42.36	1.65	1.10	50.54	7.78	57.51
2160	49.67	35.50	1.60	1.06	50.24	7.72	56.86
2200	49.91	39.65	1.61	1.33	50.23	7.74	56.99
2260	50.85	34.67	1.64	1.29	50.06	7.71	57.51
2300	51.15	35.36	1.64	1.31	50.09	7.68	56.93
2360	50.74	34.30	1.58	1.18	50.03	7.69	55.91
2400	49.04	38.65	1.47	1.06	50.10	7.79	56.00

