

Voltage Controlled Oscillator

ZX95-988+

5V Tuning for PLL IC's 941 to 988 MHz

Features

- linear tuning characteristics
- low phase noise
- low pushing
- low pulling
- protected by US patent 6,790,049



CASE STYLE: GB956

Connectors	Model
SMA	ZX95-988-S+

Applications

- r & d
- lab
- instrumentation
- wireless communications
- cellular infrastructure

+RoHS Compliant
The +Suffix identifies RoHS Compliance. See our web site for RoHS Compliance methodologies and qualifications

Electrical Specifications

MODEL NO.	FREQ. (MHz)		POWER OUTPUT (dBm)	PHASE NOISE dBc/Hz SSB at offset frequencies, kHz				TUNING					NON HARMONIC SPURIOUS (dBc)	HARMONICS (dBc)		PULLING pk-pk @12 dB (MHz)	PUSHING (MHz/V)	DC OPERATING POWER				
	Min.	Max.		Typ.	1	10	100	1000	VOLTAGE RANGE (V)		PORT CAP (pF)	3 dB MODULATION BANDWIDTH (MHz)		Typ.	Typ.			Max.	Typ.	Max.	Vcc (volts)	Current (mA)
									Min.	Max.												
ZX95-988+	941	988	+0.5	-85	-111	-132	-152	0.5	4.5	23-29	44	40	-90	-21	-13	0.8	0.2	5	20			

Maximum Ratings

Operating Temperature	-55°C to 85°C
Storage Temperature	-55°C to 100°C
Absolute Max. Supply Voltage (Vcc)	7V
Absolute Max. Tuning Voltage (Vtune)	7V
All specifications	50 ohm system

Permanent damage may occur if any of these limits are exceeded.



NOTE: When soldering the DC connections, caution must be used to avoid overheating the DC terminals. See Application Note AN-40-10.

Outline Drawing

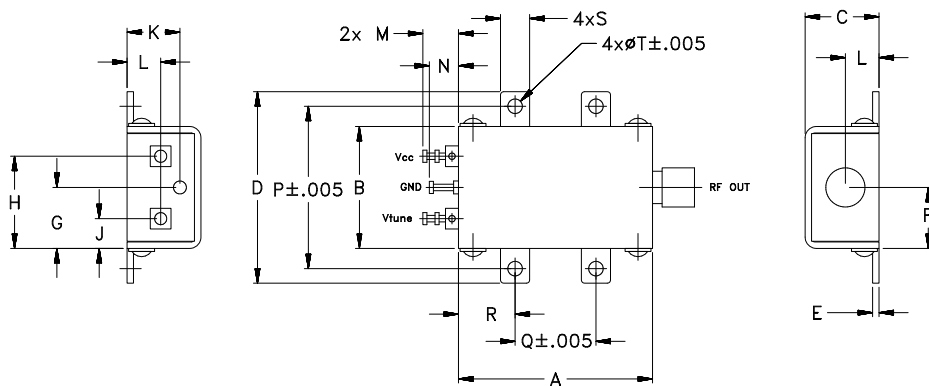

Outline Dimensions (inch/mm)

A	B	C	D	E	F	G	H	J	K	L	M	N	P	Q	R	S	T	wt.
1.20	.75	.46	1.18	.04	.38	.38	.57	.18	.33	.21	.22	.18	1.00	.50	.35	.18	.106	grams
30.48	19.05	11.68	29.97	1.02	9.65	9.65	14.48	4.57	8.38	5.33	5.59	4.57	25.40	12.70	8.89	4.57	2.69	35.0

Notes

- A. Performance and quality attributes and conditions not expressly stated in this specification document are intended to be excluded and do not form a part of this specification document.
- B. Electrical specifications and performance data contained in this specification document are based on Mini-Circuit's applicable established test performance criteria and measurement instructions.
- C. The parts covered by this specification document are subject to Mini-Circuits standard limited warranty and terms and conditions (collectively, "Standard Terms"); Purchasers of this part are entitled to the rights and benefits contained therein. For a full statement of the Standard Terms and the exclusive rights and remedies thereunder, please visit Mini-Circuits' website at www.minicircuits.com/MCLStore/terms.jsp



Performance Data & Curves*

ZX95-988+

V TUNE	TUNE SENS (MHz/V)	FREQUENCY (MHz)			POWER OUTPUT (dBm)			Icc (mA)	HARMONICS (dBc)			FREQ. PUSH (MHz/V)	FREQ. PULL (MHz)	PHASE NOISE (dBc/Hz) at offsets				FREQ OFFSET (KHz)	PHASE NOISE at 965 MHz (dBc/Hz)
		-55°C	+25°C	+85°C	-55°C	+25°C	+85°C		F2	F3	F4			1kHz	10kHz	100kHz	1MHz		
0.00	46.10	904.1	896.7	890.4	-1.04	-0.39	-0.11	13.24	-28.3	-23.5	-45.0	1.65	1.45	-78.9	-105.9	-127.8	-147.8	1.0	-85.70
0.25	38.95	914.7	908.2	902.8	-0.84	-0.16	0.16	13.33	-26.2	-24.3	-43.5	1.10	1.33	-81.0	-107.4	-129.5	-148.8	2.0	-93.59
0.50	34.60	923.9	918.0	913.0	-0.69	0.00	0.33	13.40	-24.8	-24.6	-42.7	0.79	1.28	-82.0	-108.4	-130.4	-149.8	3.5	-101.25
0.75	31.66	932.2	926.6	922.0	-0.56	0.12	0.45	13.46	-24.0	-24.5	-41.5	0.59	1.22	-83.3	-109.6	-130.7	-151.0	6.0	-105.75
1.00	29.52	939.9	934.5	930.1	-0.46	0.23	0.55	13.51	-23.4	-24.8	-41.5	0.44	1.14	-84.4	-109.9	-131.2	-151.6	8.5	-109.59
1.25	27.94	947.1	941.9	937.7	-0.36	0.32	0.64	13.57	-22.9	-25.2	-40.9	0.33	1.03	-84.2	-110.2	-131.9	-151.7	10.0	-110.86
1.50	26.71	953.9	948.9	944.8	-0.27	0.41	0.72	13.61	-22.3	-25.6	-40.8	0.24	0.91	-83.8	-110.8	-132.1	-151.6	20.8	-118.28
1.75	25.77	960.5	955.6	951.5	-0.20	0.48	0.79	13.65	-22.0	-25.8	-40.1	0.16	0.75	-83.8	-111.0	-132.3	-152.8	35.5	-123.55
2.00	25.05	966.9	962.0	958.0	-0.13	0.55	0.85	13.69	-21.8	-25.9	-40.3	0.10	0.58	-84.2	-110.7	-132.6	-152.5	60.7	-127.31
2.25	24.49	973.1	968.3	964.3	-0.07	0.61	0.91	13.71	-21.2	-26.4	-40.2	0.04	0.39	-85.8	-111.0	-133.0	-153.0	86.7	-131.06
2.50	24.04	979.2	974.4	970.5	-0.03	0.67	0.97	13.74	-20.7	-27.0	-40.2	0.01	0.25	-84.9	-111.3	-133.0	-152.4	100.0	-132.35
2.75	23.71	985.1	980.4	976.5	0.01	0.71	1.01	13.76	-20.4	-27.6	-39.9	0.07	0.30	-86.8	-111.5	-132.9	-152.9	148.1	-135.92
3.00	23.41	991.0	986.3	982.5	0.05	0.75	1.04	13.77	-20.1	-28.1	-40.5	0.13	0.52	-85.5	-111.3	-132.9	-152.9	211.6	-139.17
3.25	23.11	996.8	992.2	988.3	0.09	0.77	1.06	13.79	-20.0	-28.8	-41.3	0.20	0.71	-85.7	-111.7	-133.1	-152.8	361.5	-143.65
3.50	22.86	1002.6	998.0	994.2	0.12	0.77	1.05	13.81	-20.3	-29.2	-41.2	0.28	0.87	-85.3	-111.8	-132.8	-152.8	432.2	-144.67
3.75	22.63	1008.2	1003.7	999.9	0.08	0.74	1.03	13.82	-20.3	-29.5	-41.0	0.36	0.99	-85.8	-111.7	-131.3	-154.1	507.5	-146.66
4.00	22.46	1013.8	1009.3	1005.6	0.02	0.68	0.98	13.82	-20.2	-29.2	-40.5	0.43	1.07	-86.3	-111.8	-133.4	-153.3	606.7	-148.04
4.25	22.33	1019.4	1015.0	1011.2	-0.01	0.62	0.92	13.83	-20.1	-28.9	-40.7	0.49	1.12	-86.5	-111.8	-133.5	-153.0	851.6	-151.02
4.50	22.20	1025.0	1020.5	1016.8	-0.07	0.58	0.88	13.84	-20.0	-28.8	-40.9	0.56	1.13	-86.2	-111.5	-133.3	-153.6	1000.0	-152.25

*at 25°C unless mentioned otherwise

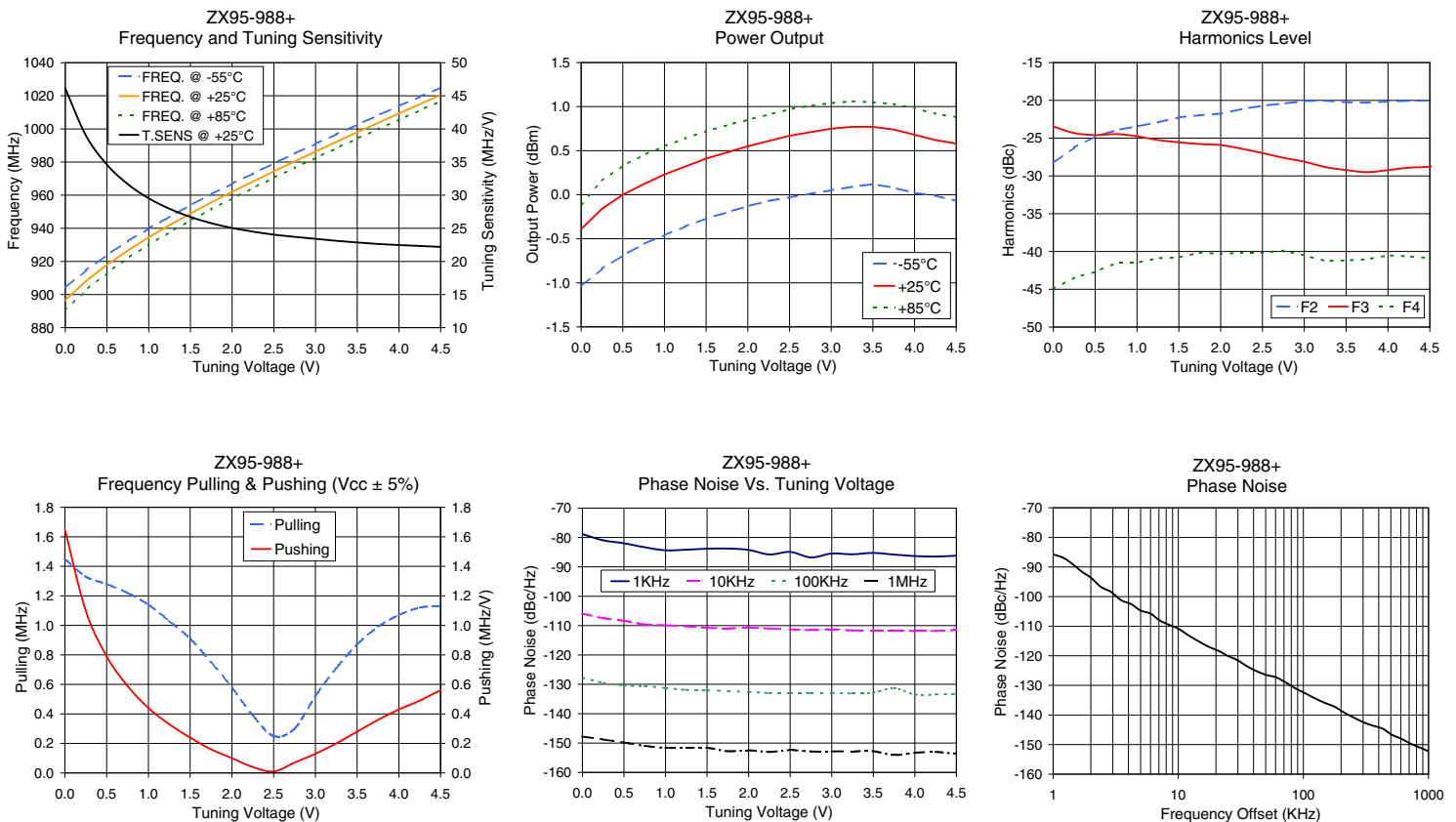

Notes

- A. Performance and quality attributes and conditions not expressly stated in this specification document are intended to be excluded and do not form a part of this specification document.
- B. Electrical specifications and performance data contained in this specification document are based on Mini-Circuit's applicable established test performance criteria and measurement instructions.
- C. The parts covered by this specification document are subject to Mini-Circuits standard limited warranty and terms and conditions (collectively, "Standard Terms"); Purchasers of this part are entitled to the rights and benefits contained therein. For a full statement of the Standard Terms and the exclusive rights and remedies thereunder, please visit Mini-Circuits' website at www.minicircuits.com/MCLStore/terms.jsp

