

# Coaxial Switch

# NON-CATALOG

# ZYSW-2-50DR

50Ω SPDT, TTL Driver, Reflective DC<sup>2</sup> to 5 GHz



CASE STYLE: ZZ121

Connectors	Model
SMA	ZYSW-2-50DR
BRACKET (OPTION "B")	

## Maximum Ratings

Operating Temperature	-20°C to 85°C
Storage Temperature	-55°C to 100°C
Input Power	
DC-2000MHz	+22dBm
2000-5000MHz	+24dBm
Permanent damage may occur if any of these limits are exceeded.	

## Coaxial/Pin Connections

RF IN	3
RF OUT 1	2
RF OUT 2	1
TTL-IN	4
+5V	+5VDC
-5V	-5VDC

## Features

- wideband, DC to 5 GHz
- fast rise/fall time, 6ns typ.
- low video break thru, 30 mV P-P typ.

## Applications

- antenna switching
- instrumentation
- cellular/PCN
- transmitters/receivers
- satellite communications

## Electrical Specifications

FREQ. <sup>2</sup> (GHz)	INSERTION LOSS (dB)						1dB COMPR. (dBm)						IN-OUT ISOLATION (dB)						
	DC-500 MHz		500-2000 MHz		2000-5000 MHz		DC-500 MHz		500-2000 MHz		2000-5000 MHz		DC-500 MHz		500-2000 MHz		2000-5000 MHz		
	f <sub>i</sub>	f <sub>u</sub>	Typ.	Max.	Typ.	Max.	Typ.	Max.	Typ.	Min.	Typ.	Min.	Typ.	Min.	Typ.	Min.	Typ.	Min.	
DC	5	0.9	1.5	1.3	1.7	2.1	—	20	15	23	19	21	18	44	38	38	28	20	—

## Outline Drawing

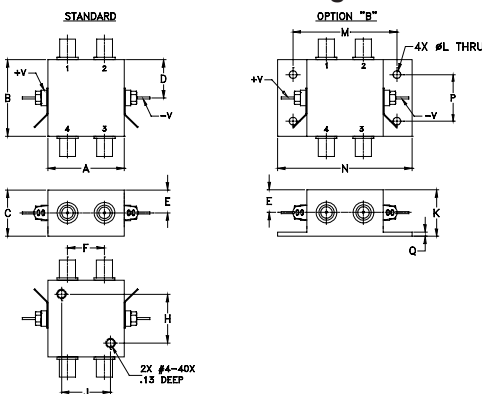

## Outline Dimensions (inch/mm)

A	B	C	D	E	F	G	H
1.25	1.25	0.75	0.63	0.38	0.61	--	0.800
31.75	31.75	19.05	16.00	9.65	15.49	--	20.32
J	K	L	M	N	P	Q	wt
0.800	0.76	0.125	1.688	2.18	0.75	0.07	grams
20.32	19.30	3.18	42.88	55.37	19.05	1.78	85

## Additional Specifications

Control Voltage	0/5.5, max.	VSWR:(1)	1.4 typ., 2.0 max. DC to 3 GHz
Low Threshold, max.	0.8		2.5 max. 3 to 5 GHz
High Threshold, min.	2.0		
Control Current, mA	High V: 2 typ., 5 max. Low V: 0.2 max.	Rise/Fall time (10%-90%), ns	6 typ., 12 max.
Positive Supply, V	+5+0.5/-0.1	Switching time, 50% of Control to 90% RF (Turn-on), ns	20 typ., 40 max.
Negative Supply, V	-5-0.5/+0.1	10% RF (Turn-off), ns	
Positive Supply Current, mA	20 max.	**Video Leakage, mVp-p 0/-5V Control	30 typ.
Negative Supply Current, mA	20 max.		

1. OFF state at RF output is low impedance
- \*\* Video leakage or break through is defined as leakage of TTL switching signal to RF output ports.
2. All RF connections must be DC blocked or held at 0V DC

Control Port	RF outputs	
	1	2
Low	On	Off
High	Off	On

## Electrical Schematic

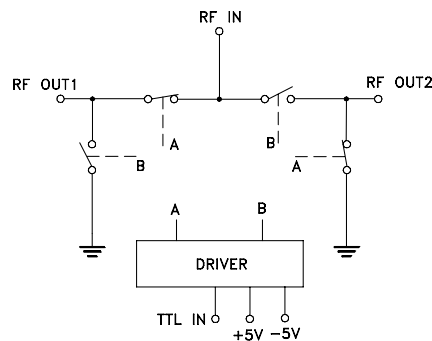

## Notes

- Performance and quality attributes and conditions not expressly stated in this specification document are intended to be excluded and do not form a part of this specification document.
- Electrical specifications and performance data contained in this specification document are based on Mini-Circuit's applicable established test performance criteria and measurement instructions.
- The parts covered by this specification document are subject to Mini-Circuits standard limited warranty and terms and conditions (collectively, "Standard Terms"); Purchasers of this part are entitled to the rights and benefits contained therein. For a full statement of the Standard Terms and the exclusive rights and remedies thereunder, please visit Mini-Circuits' website at [www.minicircuits.com/MCLStore/terms.jsp](http://www.minicircuits.com/MCLStore/terms.jsp)



## Typical Performance Data

FREQ. (MHz)	ON				OFF				VSWR		
	TTL Low @ 0V		INSERTION LOSS (dB)		TTL High @ 5V		ISOLATION (dB)		IN	OUT	
	IN-OUT 1		AMP. UNBAL.		IN-OUT 1		DELTA			ON	OFF
	$\bar{x}$	$\sigma$	$\bar{x}$	$\sigma$	$\bar{x}$	$\sigma$	$\bar{x}$	$\sigma$	$\bar{x}$	$\bar{x}$	$\bar{x}$
3.00	0.93	0.03	0.01	0.00	82.19	2.73	4.56	2.14	1.20	1.21	5.09
5.00	0.93	0.03	0.01	0.01	81.63	2.81	2.23	1.14	1.21	1.21	5.07
10.00	0.93	0.02	0.01	0.01	75.09	1.32	1.62	0.75	1.21	1.21	5.08
20.00	0.98	0.03	0.05	0.04	69.97	0.76	1.59	1.48	1.21	1.21	5.06
50.00	0.94	0.03	0.01	0.01	63.18	0.95	1.77	0.64	1.20	1.20	5.04
100.00	0.96	0.03	0.01	0.00	57.83	0.41	0.52	0.21	1.20	1.20	5.00
200.00	0.98	0.03	0.01	0.00	52.68	0.23	0.35	0.28	1.20	1.20	4.97
500.00	1.03	0.03	0.00	0.00	45.93	0.26	0.34	0.16	1.23	1.24	4.90
1000.00	1.11	0.03	0.01	0.01	40.28	0.28	0.34	0.14	1.29	1.29	5.01
1150.64	1.11	0.02	0.01	0.01	38.91	0.25	0.37	0.13	1.31	1.31	5.07
1724.45	1.24	0.01	0.03	0.02	34.88	0.27	0.32	0.09	1.33	1.33	5.43
2441.73	1.11	0.01	0.01	0.01	32.17	0.39	0.21	0.13	1.26	1.26	6.07
2561.27	1.17	0.03	0.02	0.02	31.99	0.39	0.14	0.12	1.24	1.23	6.23
2848.18	1.18	0.02	0.01	0.01	31.20	0.40	0.13	0.07	1.20	1.19	5.96
3135.09	1.19	0.09	0.04	0.04	30.98	0.42	0.15	0.17	1.14	1.13	6.12
3708.91	1.22	0.03	0.06	0.02	30.08	0.46	0.38	0.38	1.16	1.13	6.11
4282.73	1.38	0.10	0.11	0.02	28.98	0.46	0.82	0.28	1.33	1.32	6.05
4713.09	1.45	0.04	0.05	0.04	29.12	0.35	0.88	0.29	1.37	1.34	5.07
4856.55	1.51	0.04	0.06	0.04	28.90	0.33	0.84	0.25	1.36	1.39	5.02
5000.00	1.54	0.04	0.06	0.04	28.56	0.30	0.87	0.28	1.35	1.40	4.92

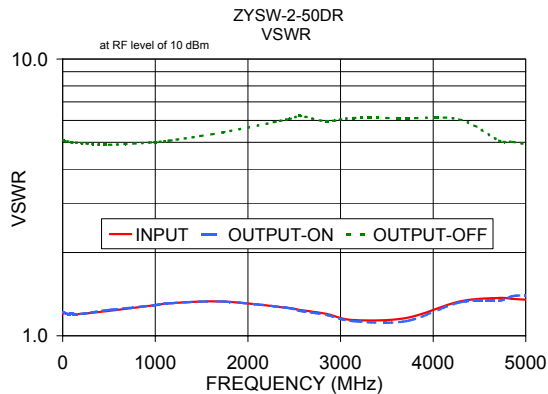
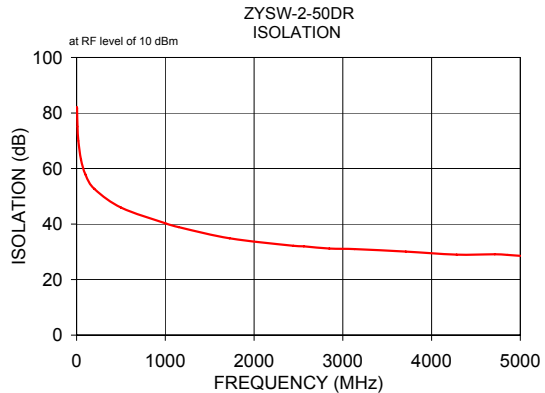
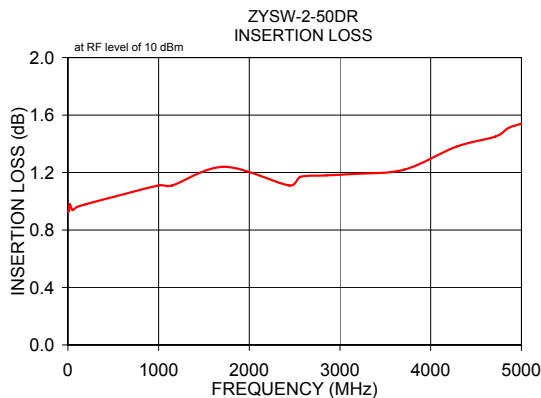

### Notes

- A. Performance and quality attributes and conditions not expressly stated in this specification document are intended to be excluded and do not form a part of this specification document.
- B. Electrical specifications and performance data contained in this specification document are based on Mini-Circuit's applicable established test performance criteria and measurement instructions.
- C. The parts covered by this specification document are subject to Mini-Circuits standard limited warranty and terms and conditions (collectively, "Standard Terms"); Purchasers of this part are entitled to the rights and benefits contained therein. For a full statement of the Standard Terms and the exclusive rights and remedies thereunder, please visit Mini-Circuits' website at [www.minicircuits.com/MCLStore/terms.jsp](http://www.minicircuits.com/MCLStore/terms.jsp)