



MMIC SURFACE MOUNT

Power Splitter/Combiner

GP2X+

2 Way-0° 50Ω 2900 to 6200 MHz

FEATURES

- Wide Bandwidth, 2900 to 6200 MHz
- Excellent Amplitude Unbalance, Typ. 0.04 dB
- Good Phase Unbalance, Typ. 4 deg.
- Small Size, 0.118" x 0.118" x 0.035"
- High ESD Level
- Aqueous Washable

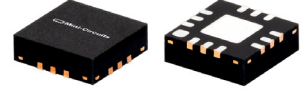

Generic photo used for illustration purposes only

CASE STYLE: DQ1225

+RoHS Compliant

The +Suffix identifies RoHS Compliance. See our website for methodologies and qualifications

APPLICATIONS

- ISM
- Instrumentation
- Radar
- WLAN
- Satellite Communications

ELECTRICAL SPECIFICATIONS AT +25°C

Parameter	Frequency (MHz)	Min.	Typ.	Max.	Units
Frequency Range		2900		6200	MHz
Insertion Loss* (Above 3.0 dB)	2900-6200		0.6	1.5	dB
Isolation	2900-6200	15	24		dB
Amplitude Unbalance	2900-6200		0.05	0.3	dB
Phase Unbalance	2900-6200		4.0	9.0	deg.
VSWR (Port S)	2900-6200		1.2		:1
VSWR (Ports 1,2)	2900-6200		1.2		

* De-embedded from demo board loss.

ABSOLUTE MAXIMUM RATINGS

Parameter	Ratings
Operating Temperature	-40°C to +85°C
Storage Temperature	-65°C to +150°C
Power Input (as a Splitter)	1.5 W max.
Internal Dissipation	0.75 W max.

Permanent damage may occur if any of these limits are exceeded.

ELECTRICAL SCHEMATIC





MMIC SURFACE MOUNT

Power Splitter/Combiner

GP2X+

Mini-Circuits

2 Way-0° 50Ω 2900 to 6200 MHz

PAD CONNECTIONS

SUM PORT	2
PORT 1	7
PORT 2	9
GROUND	1,3,4,5,6,8,10,11,12, Paddle

DEMO BOARD MCL P/N: TB-453-GPX+ SUGGESTED PCB LAYOUT (PL-282)

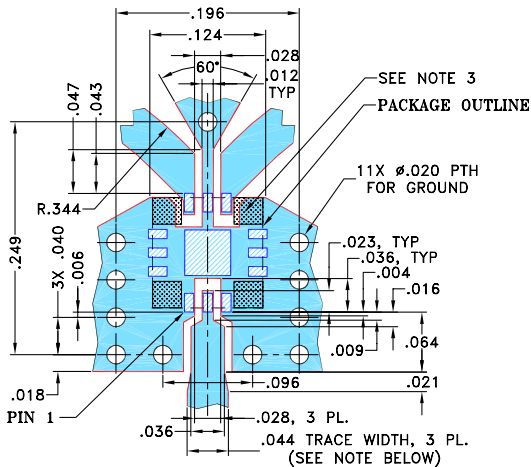

NOTES:

1. TRACE WIDTH IS SHOWN FOR ROGERS R04350B WITH DIELECTRIC THICKNESS .020" ± .0015"; COPPER: 1/2 OZ. EACH SIDE. FOR OTHER MATERIALS TRACE WIDTH AND GAP MAY NEED TO BE MODIFIED.
2. BOTTOM SIDE OF THE PCB IS CONTINUOUS GROUND PLANE.
3. SIGNAL TRACES ARE NOT ALLOWED INSIDE HATCHED AREAS (APPROX. .030 X .030) AT 4 PLACES AS SHOWN.

- DENOTES PCB COPPER LAYOUT WITH SMOBC (SOLDER MASK OVER BARE COPPER)
- DENOTES COPPER LAND PATTERN FREE OF SOLDER MASK

PRODUCT MARKING

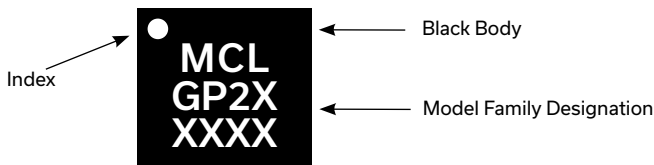

Marking may contain other features or characters for internal lot control.

OUTLINE DRAWING

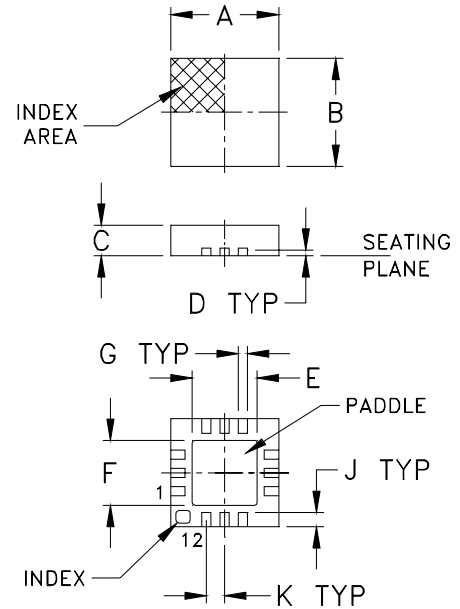

PCB Land Pattern

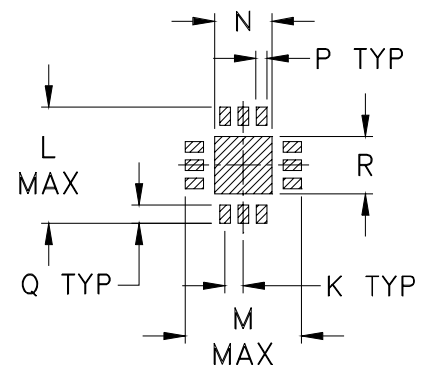

Suggested Layout,
Tolerance to be within ±.002

OUTLINE DIMENSIONS (Inch/mm)

A	B	C	D	E	F	G	H	J
.118	.118	.035	.008	.057	.057	.009	---	.016
3.00	3.00	0.89	0.20	1.45	1.45	0.23	---	0.41
K	L	M	N	P	Q	R		wt
.020	.127	.127	.049	.010	.020	.049		grams
0.51	3.23	3.23	1.24	0.25	0.51	1.24		0.02

TAPE & REEL INFORMATION: F66

Mini-Circuits



MMIC SURFACE MOUNT

Power Splitter/Combiner

GP2X+

2 Way-0° 50Ω 2900 to 6200 MHz

TYPICAL PERFORMANCE DATA AND CHARTS

Frequency (MHz)	Total Loss ¹ (dB)		Amplitude Unbalance (dB)	Isolation (dB)	Phase Unbalance (deg.)	VSWR S	VSWR 1	VSWR 2
	S-1	S-2						
2900	3.78	3.84	0.06	22.02	2.44	1.08	1.14	1.11
3360	3.64	3.68	0.04	21.14	2.92	1.33	1.16	1.13
3540	3.61	3.64	0.03	20.67	3.08	1.36	1.15	1.11
3720	3.57	3.59	0.03	20.82	3.20	1.34	1.14	1.08
3900	3.52	3.55	0.02	21.57	3.30	1.28	1.12	1.04
4080	3.48	3.52	0.03	22.89	3.42	1.20	1.09	1.01
4270	3.46	3.49	0.04	25.19	3.58	1.12	1.05	1.06
4450	3.44	3.49	0.04	29.16	3.77	1.09	1.01	1.11
4990	3.51	3.53	0.02	28.55	4.38	1.29	1.13	1.22
5170	3.55	3.56	0.01	24.69	4.58	1.36	1.16	1.22
5540	3.61	3.62	0.01	20.83	4.94	1.45	1.18	1.18
5720	3.62	3.64	0.03	19.75	5.14	1.45	1.17	1.13
5900	3.61	3.66	0.05	18.68	5.49	1.45	1.16	1.09
6080	3.60	3.65	0.05	17.77	5.73	1.43	1.13	1.05
6260	3.59	3.65	0.05	17.10	6.01	1.40	1.10	1.05

1. Total Loss=Insertion Loss + 3 dB splitter loss.

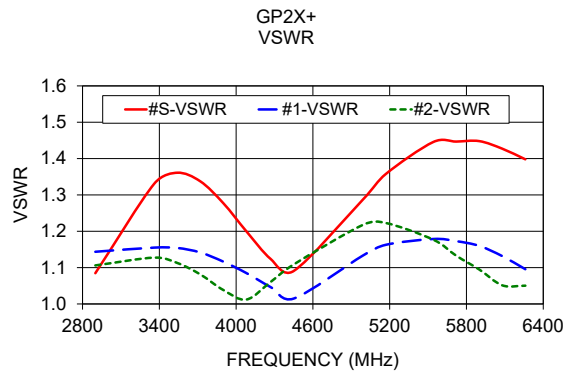
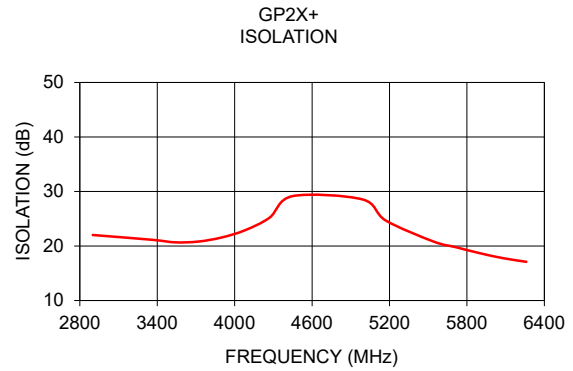
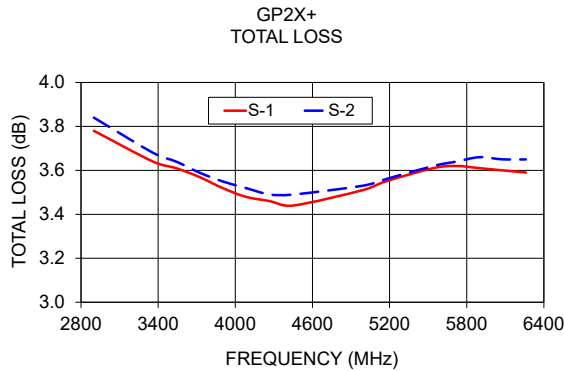

ESD RATING

Human Body Model (HBM): Class 1A (250 V to < 500 V) in accordance with ANSI/ESD STM 5.1 - 2001

Machine Model (MM): Class M2 (100 V to < 250 V) in accordance with ANSI/ESD STM 5.2 - 1999

NOTES

- A. Performance and quality attributes and conditions not expressly stated in this specification document are intended to be excluded and do not form a part of this specification document.
- B. Electrical specifications and performance data contained in this specification document are based on Mini-Circuit's applicable established test performance criteria and measurement instructions.
- C. The parts covered by this specification document are subject to Mini-Circuits standard limited warranty and terms and conditions (collectively, "Standard Terms"); Purchasers of this part are entitled to the rights and benefits contained therein. For a full statement of the standard terms and the exclusive rights and remedies thereunder, please visit Mini-Circuits' website at www.minicircuits.com/terms/viewterm.html



2 Way-0° Power Splitter/Combiner

GP2X+

Typical Performance Data

FREQUENCY (MHz)	TOTAL LOSS ¹ (dB)		AMPLITUDE UNBALANCE (dB)	ISOLATION (dB) 1-2	PHASE UNBALANCE (Deg)	FREQUENCY (MHz)	VSWR (:1)		
	S-1	S-2					S	1	2
2900.00	3.78	3.84	0.06	22.02	2.44	2900.00	1.08	1.14	1.11
3000.00	3.71	3.77	0.06	23.54	2.53	3000.00	1.07	1.13	1.10
3180.00	3.66	3.71	0.05	22.58	2.72	3180.00	1.23	1.14	1.12
3360.00	3.64	3.68	0.04	21.14	2.92	3360.00	1.33	1.16	1.13
3540.00	3.61	3.64	0.03	20.67	3.08	3540.00	1.36	1.15	1.11
3720.00	3.57	3.59	0.03	20.82	3.20	3720.00	1.34	1.14	1.08
3900.00	3.52	3.55	0.02	21.57	3.30	3900.00	1.28	1.12	1.04
4080.00	3.48	3.52	0.03	22.89	3.42	4080.00	1.20	1.09	1.01
4270.00	3.46	3.49	0.04	25.19	3.58	4270.00	1.12	1.05	1.06
4450.00	3.44	3.49	0.04	29.16	3.77	4450.00	1.09	1.01	1.11
4630.00	3.45	3.49	0.04	38.44	3.97	4630.00	1.13	1.05	1.15
4810.00	3.47	3.51	0.03	37.75	4.17	4810.00	1.21	1.09	1.19
4990.00	3.51	3.53	0.02	28.55	4.38	4990.00	1.29	1.13	1.22
5170.00	3.55	3.56	0.01	24.69	4.58	5170.00	1.36	1.16	1.22
5360.00	3.58	3.59	0.01	22.40	4.75	5360.00	1.41	1.18	1.21
5540.00	3.61	3.62	0.01	20.83	4.94	5540.00	1.45	1.18	1.18
5720.00	3.62	3.64	0.03	19.75	5.14	5720.00	1.45	1.17	1.13
5900.00	3.61	3.66	0.05	18.68	5.49	5900.00	1.45	1.16	1.09
6080.00	3.60	3.65	0.05	17.77	5.73	6080.00	1.43	1.13	1.05
6260.00	3.59	3.65	0.05	17.10	6.01	6260.00	1.40	1.10	1.05

¹Total Loss = Insertion Loss + 3dB Splitter Loss



P.O. Box 350166, Brooklyn, New York 11235-0003 (718) 934-4500 • Fax (718) 332-4661 For detailed performance specs & shopping online see Mini-Circuits web site
 The Design Engineers Search Engine Provides ACTUAL Data Instantly From MINI-CIRCUITS At: www.minicircuits.com



IF/RF MICROWAVE COMPONENTS

REV. X2
 GP2X+
 6/21/2010
 Page 1 of 1

2 Way-0° Power Splitter/Combiner

GP2X+

Typical Performance Curves

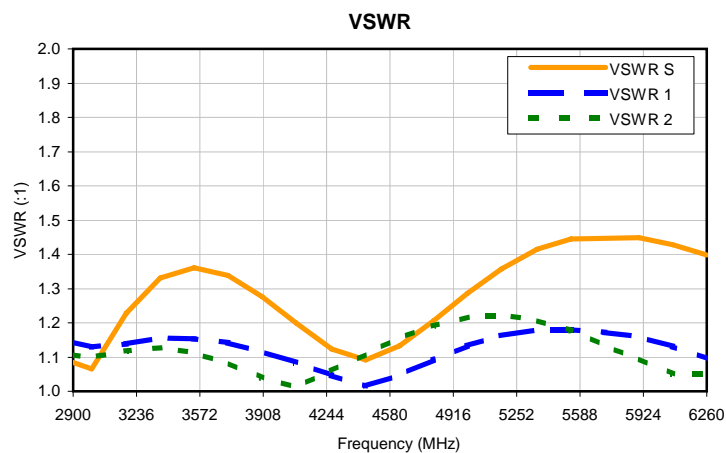
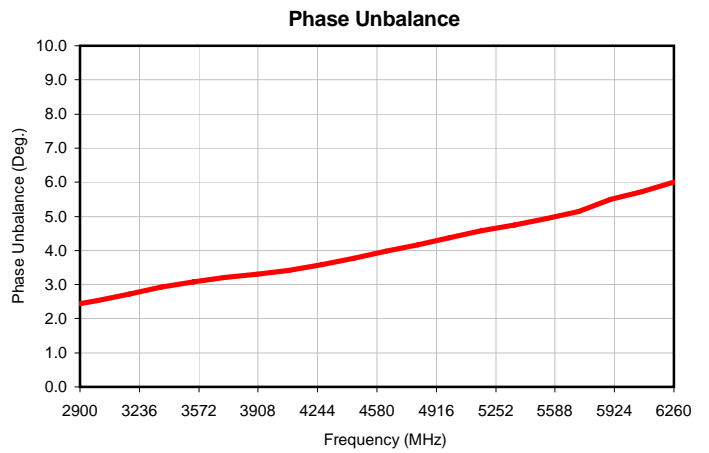
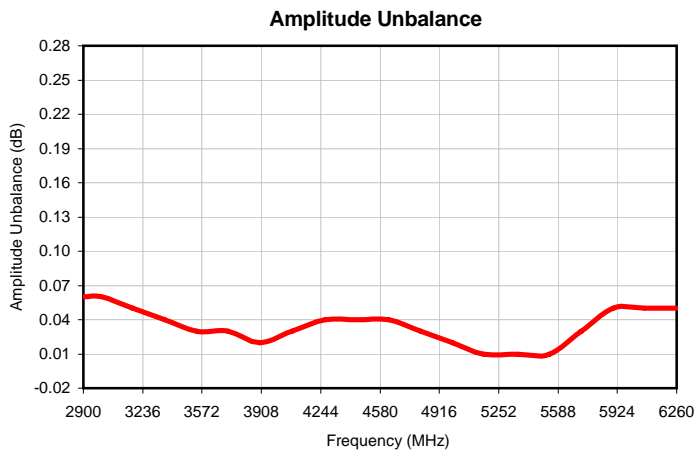
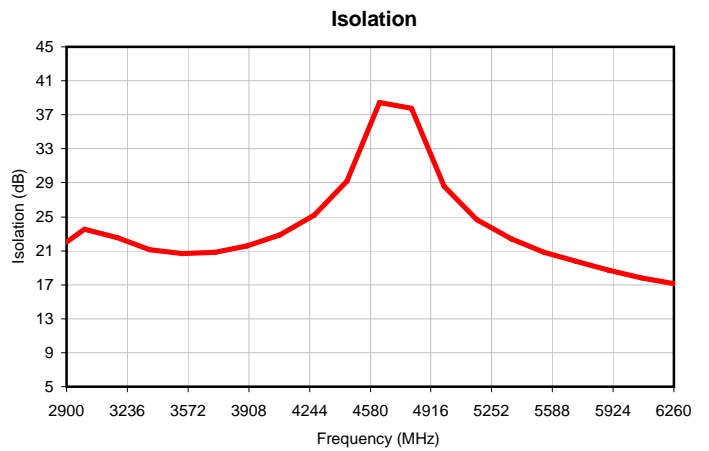
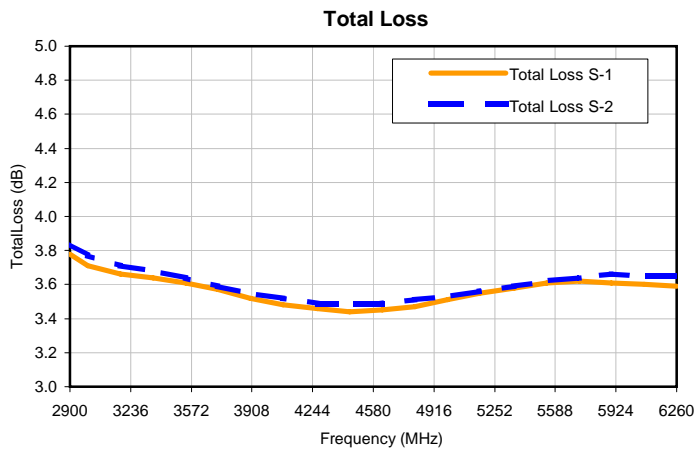

P.O. Box 350166, Brooklyn, New York 11235-0003 (718) 934-4500 • Fax (718) 332-4661 For detailed performance specs & shopping online see Mini-Circuits web site
The Design Engineers Search Engine Provides ACTUAL Data Instantly From MINI-CIRCUITS At: www.minicircuits.com



IF/RF MICROWAVE COMPONENTS

REV. X2
GP2X+
6/21/2010
Page 1 of 1

Outline Dimensions

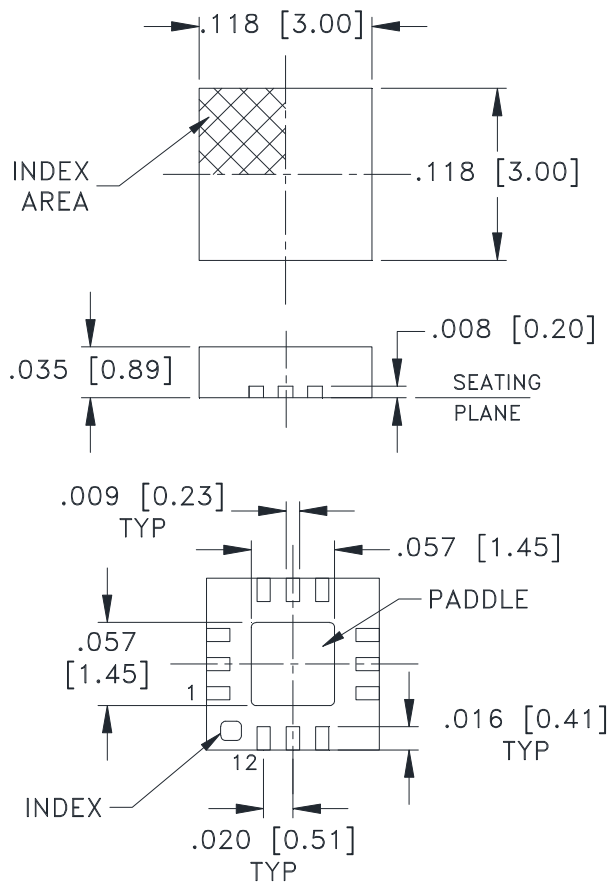

PCB Land Pattern

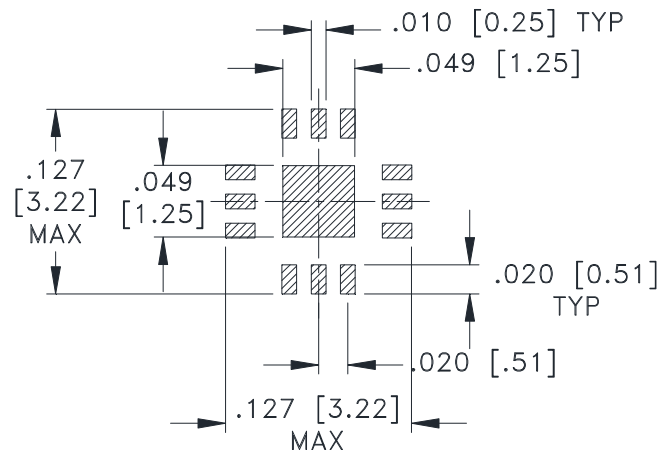

SUGGESTED LAYOUT,
TOLERANCE TO BE WITHIN $\pm .002$

Weight: .02 Grams

Dimensions are in inches (mm). Tolerances: 2Pl. $\pm .01$; 3 Pl. $\pm .004$

Notes:

1. Case material: Plastic.
2. Termination finish:
 - For RoHS Case Styles: Tin-Silver alloy plate over Nickel barrier or Matte-Tin. All models, (+) suffix. See Data sheet.
 - For RoHS-5 Case Styles: Tin-Lead plate. All models, no (+) suffix.

Mini-Circuits®

Distribution Centers NORTH AMERICA 800-654-7949 • 417-335-5935 • Fax 417-335-5945 • EUROPE 44-1252-832600 • Fax 44-1252-837010

Mini-Circuits ISO 9001 & ISO 14001 Certified

INTERNET <http://www.minicircuits.com>

P.O. Box 350166, Brooklyn, New York 11235-0003 (718) 934-4500 Fax (718) 332-4661

Tape & Reel Packaging TR-F66

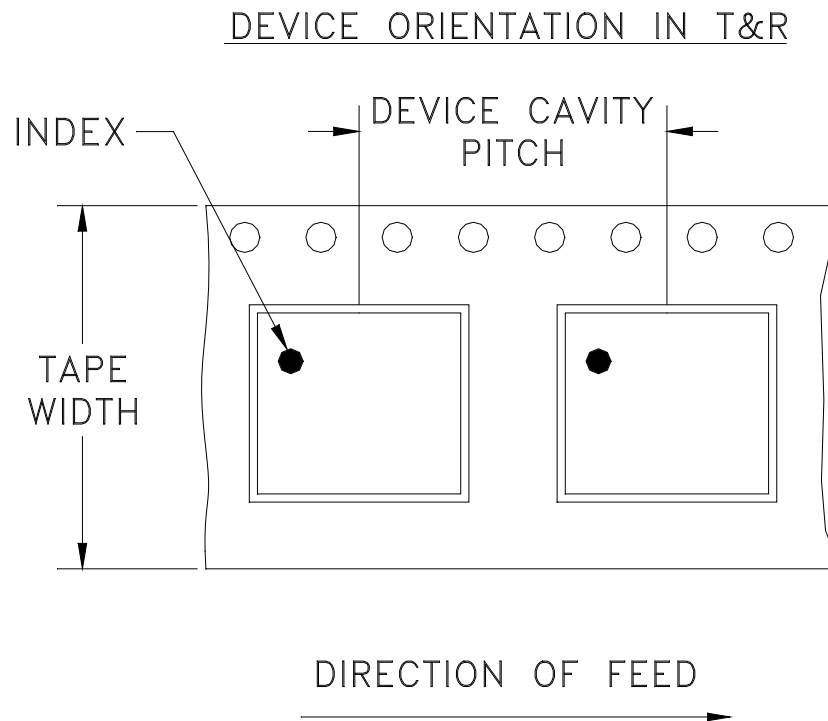

Tape Width, mm	Device Cavity Pitch, mm	Reel Size, inches	Devices per Reel see note	
8	4	7	Small quantity standard	20
				50
				100
				200
				500
		7	Standard	1000, 2000, 3000

Note: Please consult individual model data sheet to determine device per reel availability.

Mini-Circuits carrier tape materials provide protection from ESD (Electro-Static Discharge) during handling and transportation. Tapes are static dissipative and comply with industry standards EIA-481/EIA-541.

Go to: www.minicircuits.com/pages/pdfs/tape.pdf

Mini-Circuits®

INTERNET <http://www.minicircuits.com>

P.O. Box 350166, Brooklyn, New York 11235-0003 (718) 934-4500 Fax (718) 332-4661

Distribution Centers NORTH AMERICA 800-654-7949 • 417-335-5935 • Fax 417-335-5945 • EUROPE 44-1252-832600 • Fax 44-1252-837010

Mini-Circuits ISO 9001 & ISO 14001 Certified

THIRD ANGLE PROJECTION

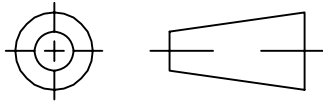

REVISIONS

REV	ECN No.	DESCRIPTION	DATE	DR	AUTH
OR	M114550	NEW RELEASE	11/15/07	AV	WP

SUGGESTED MOUNTING CONFIGURATION FOR DQ1225 CASE STYLE, "12SP02" PIN CODE

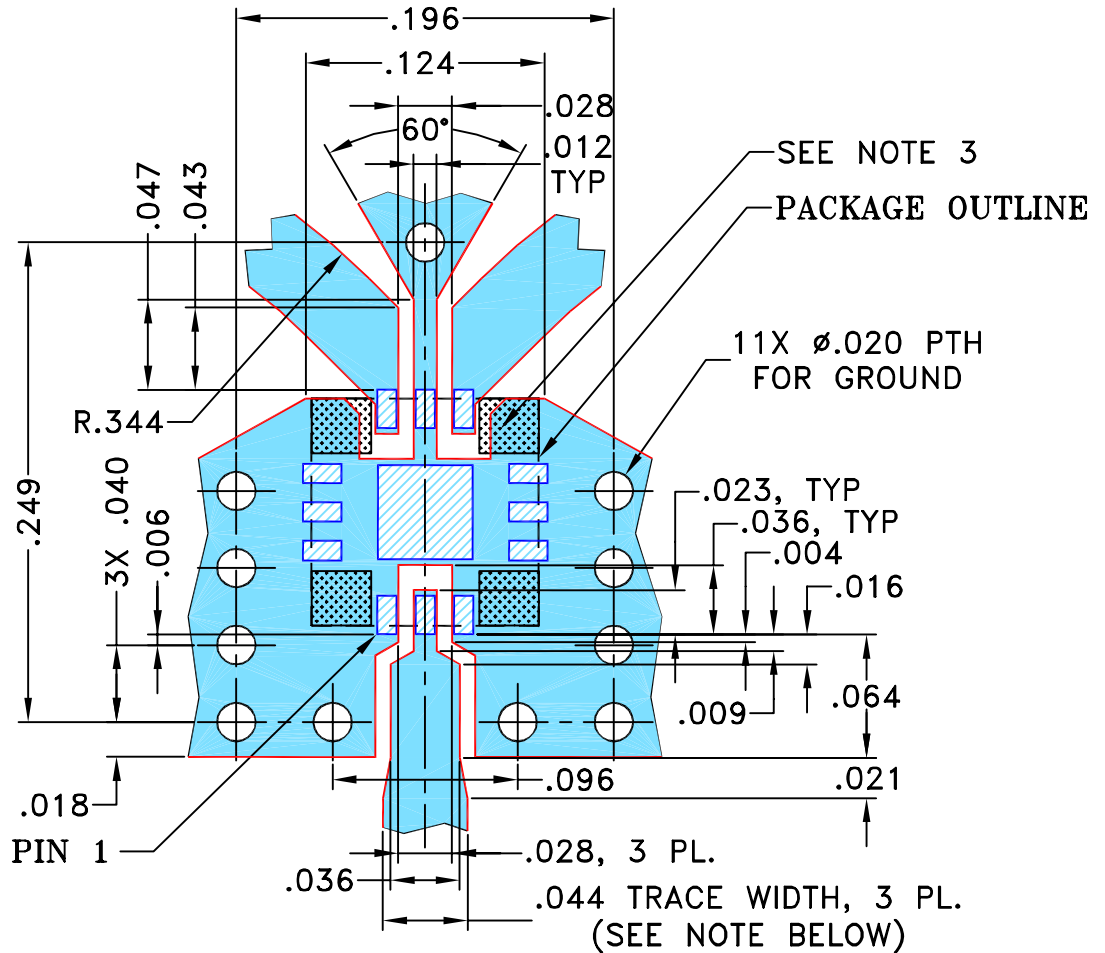

NOTES:

1. TRACE WIDTH IS SHOWN FOR ROGERS R04350B WITH DIELECTRIC THICKNESS .020" ± .0015"; COPPER: 1/2 OZ. EACH SIDE. FOR OTHER MATERIALS TRACE WIDTH AND GAP MAY NEED TO BE MODIFIED.
2. BOTTOM SIDE OF THE PCB IS CONTINUOUS GROUND PLANE.
3. SIGNAL TRACES ARE NOT ALLOWED INSIDE HATCHED AREAS (APPROX. .030 X .030) AT 4 PLACES AS SHOWN.



DENOTES PCB COPPER LAYOUT WITH SMOBC (SOLDER MASK OVER BARE COPPER)



DENOTES COPPER LAND PATTERN FREE OF SOLDER MASK

UNLESS OTHERWISE SPECIFIED	INITIALS	DATE
DRAWN	AV	11/13/07
CHECKED	MMG	11/15/07
APPROVED	WP	11/15/07

Mini-Circuits®
 THIS DOCUMENT AND ITS CONTENTS ARE THE PROPERTY OF MINI-CIRCUITS. EXCEPT FOR USE EXPRESSLY GRANTED, IN WRITING, TO ITS VENDORS, VENDEE AND THE UNITED STATES GOVERNMENT, MINI-CIRCUITS RESERVES ALL PROPRIETARY DESIGN, USE, MANUFACTURING AND REPRODUCTION RIGHTS THERETO. THESE CONTENTS SHALL NOT BE USED, DUPLICATED OR DISCLOSED TO ANY OUTSIDE PARTY, IN WHOLE OR IN PART, WITHOUT WRITTEN PERMISSION OF MINI-CIRCUITS.
 ASHEETA1.DWG REV:A DATE:01/12/95

Mini-Circuits® 13 Neptune Avenue Brooklyn NY 11235

PL, 12SP02, DQ1225, GP2, TB-453+

SIZE	CODE IDENT	DRAWING NO:	REV:
A	15542	98-PL-282	OR
FILE:	98PL282	SCALE:	10:1
SHEET:	1	OF	1

Evaluation Board and Circuit

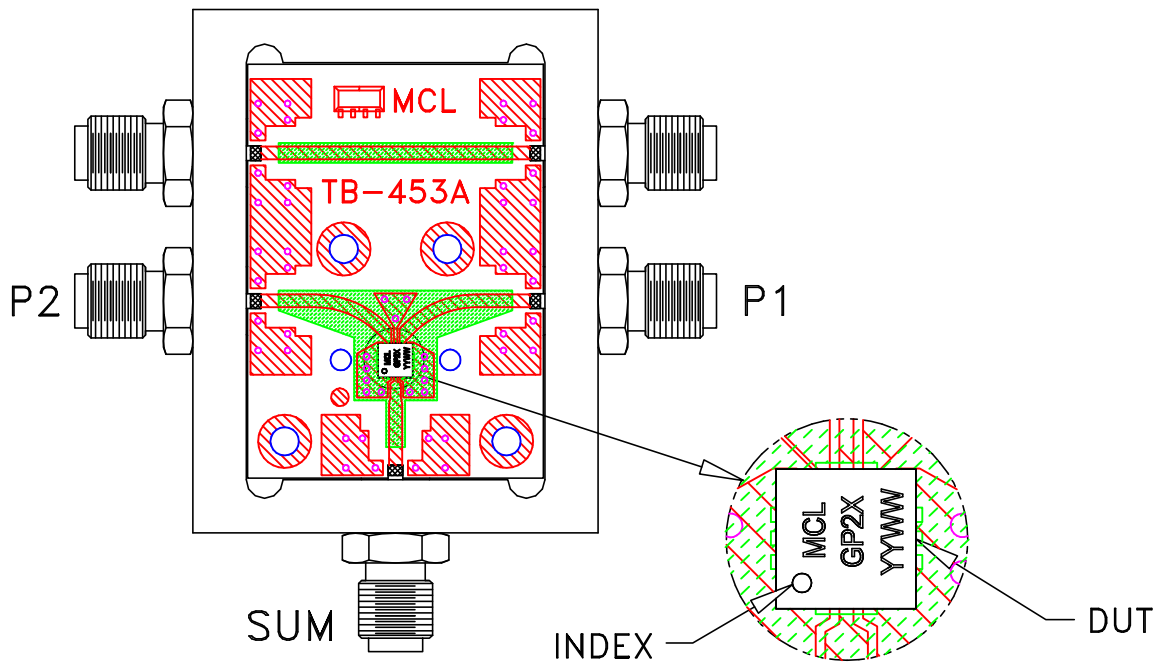

TB-453-GP2X+

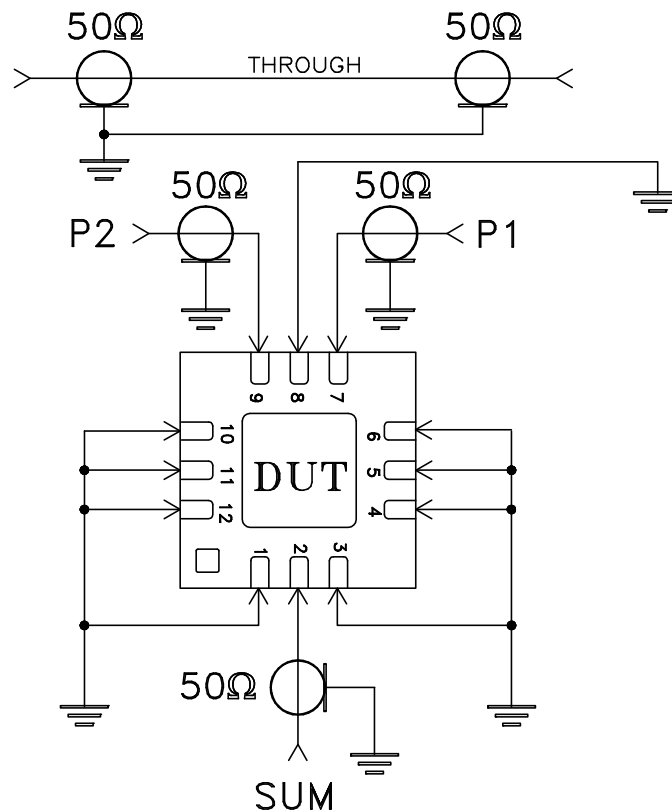

Schematic Diagram

Notes:

1. SMA Female connectors.
2. PCB Material: Rogers R04350 or equivalent, Dielectric Constant=3.5, Thickness=.020 inch.

 Mini-Circuits®

All Mini-Circuits products are manufactured under exacting quality assurance and control standards, and are capable of meeting published specifications after being subjected to any or all of the following physical and environmental test.

Specification	Test/Inspection Condition	Reference/Spec
Operating Temperature	-40° to 85° C Ambient Environment	Individual Model Data Sheet
Storage Temperature	-65° to 150° C Ambient Environment	Individual Model Data Sheet
Autoclave	15 psig, 100% RH, 121°C, 96 hours	JESD22-A102-C, Condition C
Temperature Cycling	-65° to 150°C, 100 cycles	JESD22-A104
Temperature Humidity	85°C/ 85% RH, 168 hours	JESD22-113
Solder Reflow Heat	Sn-Pb Eutetic Process: 240°C peak Pb-Free Process: 260°C peak	J-STD-020, Table 4-1, 4-2 and 5-2; Figure 5-1
Moisture Sensitivity: Level 1	Bake at 125°C for 24 hours Soak at 85°C/85% RH for 168 hours, Reflow 3 cycles at 240°C peak (Non-RoHS) or 260°C (RoHS)	J-STD-020
Solderability	10X magnification, 95% coverage	JESD22-B102, Method 1: Dip and Look Test
Mechanical Shock	50g, 11 ms, 1/2-sine, 18 shocks: 3 each direction, each of 3 axes	MIL-STD-202, Method 213, Condition A
Vibration (High Frequency)	20g peak, 10-2000 Hz, 12 times in each of three perpendicular directions (total 36)	MIL-STD-202, Method 204, Condition D