

Surface Mount Frequency Mixer

ADE-1+

Level 7 (LO Power +7 dBm) 0.5 to 500 MHz



Generic photo used for illustration purposes only

CASE STYLE: CD636

+RoHS Compliant

The +Suffix identifies RoHS Compliance. See our web site for RoHS Compliance methodologies and qualifications



Available Tape and Reel at no extra cost

Reel Size	Devices/Reel
7"	20, 50, 100, 200
13"	500, 1000

Maximum Ratings

Operating Temperature	-40°C to 85°C
Storage Temperature	-55°C to 100°C
RF Power	50mW
IF Current	40mA

Permanent damage may occur if any of these limits are exceeded. These electrical ratings are not intended for continuous normal operation.

Pin Connections

LO	6
RF	3
IF	2
GROUND	1,4,5

Outline Drawing

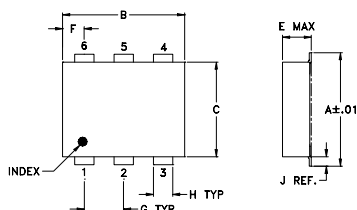

PCB Land Pattern

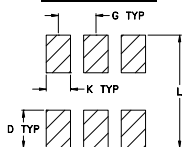

Suggested Layout.
Tolerance to be within ±.002

Outline Dimensions (inch/mm)

A	B	C	D	E	F	G
.272	.310	.220	.100	.162	.055	.100
6.91	7.87	5.59	2.54	4.11	1.40	2.54
H	J	K	L		wt	
.030	.026	.065	.300		grams	
0.76	0.66	1.65	7.62		0.25	

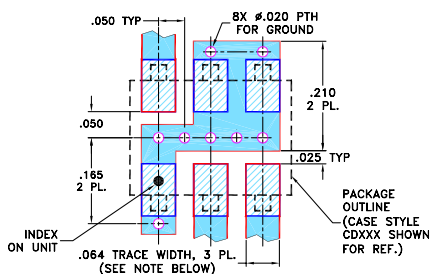

- NOTES: 1. TRACE WIDTH IS SHOWN FOR ROGERS RO4350B WITH DIELECTRIC THICKNESS .030" ± .002"; COPPER: 1/2 OZ. EACH SIDE. FOR OTHER MATERIALS TRACE WIDTH MAY NEED TO BE MODIFIED.
2. BOTTOM SIDE OF THE PCB IS CONTINUOUS GROUND PLANE.

- DENOTES PCB COPPER LAYOUT WITH SMOBC (SOLDER MASK OVER BARE COPPER)
■ DENOTES COPPER LAND PATTERN FREE OF SOLDER MASK

Notes

- A. Performance and quality attributes and conditions not expressly stated in this specification document are intended to be excluded and do not form a part of this specification document.
B. Electrical specifications and performance data contained in this specification document are based on Mini-Circuit's applicable established test performance criteria and measurement instructions.
C. The parts covered by this specification document are subject to Mini-Circuits standard limited warranty and terms and conditions (collectively, "Standard Terms"); Purchasers of this part are entitled to the rights and benefits contained therein. For a full statement of the Standard Terms and the exclusive rights and remedies thereunder, please visit Mini-Circuits' website at www.minicircuits.com/MCLStore/terms.jsp

Features

- low conversion loss, 5.0 dB typ.
- excellent L-R isolation, 55 dB typ.
- excellent IP3, 15 dBm typ.
- low profile package
- aqueous washable
- protected by US patent 6,133,525

Applications

- VHF/UHF

Electrical Specifications

FREQUENCY (MHz)	CONVERSION LOSS (dB)	LO-RF ISOLATION (dB)			LO-IF ISOLATION (dB)			IP3 at center band (dBm)										
		L	M	U	L	M	U											
LO/RF $f_L - f_U$	Mid-Band m Total Range Max.	Typ.	Min.	Typ.	Min.	Typ.	Min.	Typ.										
0.5-500	DC-500	5.0	0.10	6.5	7.8	70	50	55	35	45	30	65	45	40	25	30	20	15

1 dB COMP.: +1 dBm typ.

L = low range [f_L to $10 f_L$]
M = mid band [$2 f_L$ to $f_U/2$]
U = upper range [$f_U/2$ to f_U]

Typical Performance Data

Frequency (MHz)		Conversion Loss (dB)	Isolation L-R (dB)	Isolation L-I (dB)	VSWR RF Port (:1)	VSWR LO Port (:1)
RF	LO	LO +7dBm	LO +7dBm	LO +7dBm	LO +7dBm	LO +7dBm
0.50	30.50	5.68	67.49	56.67	1.46	2.51
0.80	30.80	5.55	67.50	56.83	1.32	2.56
1.00	31.00	5.35	67.51	56.67	1.29	2.56
5.00	35.00	5.06	66.17	55.50	1.19	2.51
10.00	40.00	4.95	65.17	54.17	1.18	2.51
20.00	50.00	5.02	63.50	52.17	1.17	2.56
40.00	70.00	4.89	61.00	48.83	1.14	2.51
63.25	93.25	4.93	58.84	46.33	1.11	2.51
94.82	124.82	4.99	58.00	44.34	1.08	2.56
100.00	130.00	5.08	58.00	43.84	1.08	2.56
126.39	156.39	4.96	56.67	42.17	1.08	2.56
157.97	187.97	5.11	54.16	41.16	1.10	2.51
221.12	251.12	5.15	51.84	40.00	1.05	2.67
250.00	280.00	5.10	53.00	38.67	1.03	2.61
284.26	314.26	5.20	48.33	36.50	1.04	2.67
347.41	377.41	5.43	47.66	33.34	1.10	2.56
378.98	408.98	5.33	47.00	30.67	1.15	2.80
410.56	440.56	5.54	45.50	29.17	1.17	2.80
470.00	500.00	5.81	44.67	28.16	1.14	3.01
500.00	530.00	5.91	43.82	28.50	1.23	3.09

Electrical Schematic

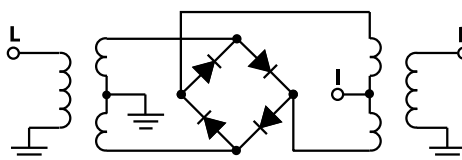

Mini-Circuits®

www.minicircuits.com P.O. Box 350166, Brooklyn, NY 11235-0003 (718) 934-4500 sales@minicircuits.com

REV. G
M158496
ADE-1+
ED-7605/1
DJ/TD/CP/AM
200421
Page 1 of 2

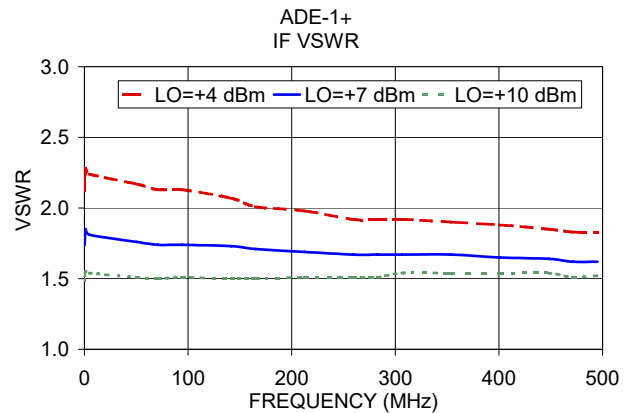
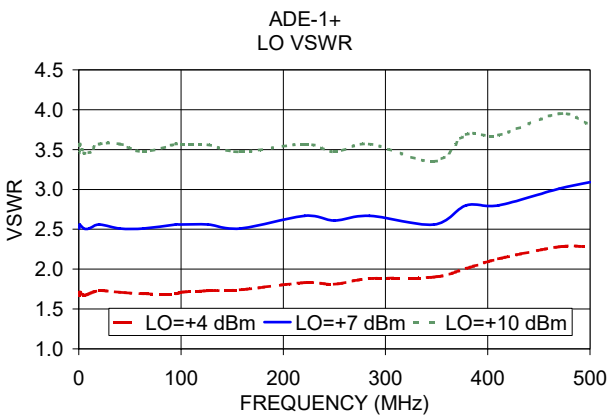
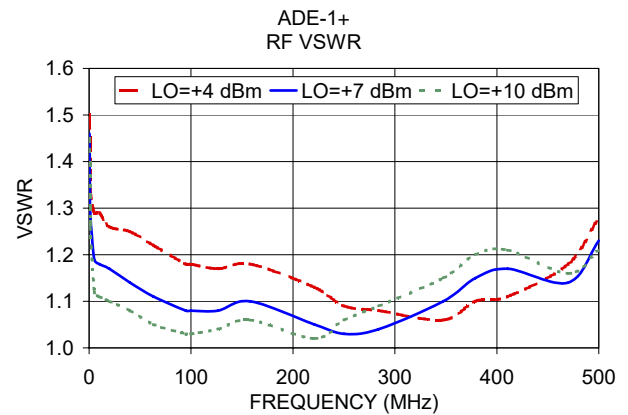
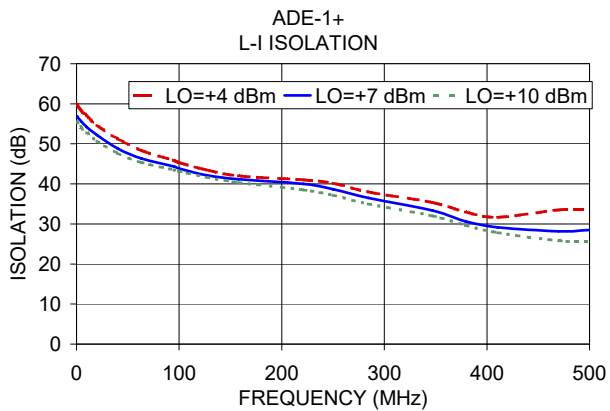
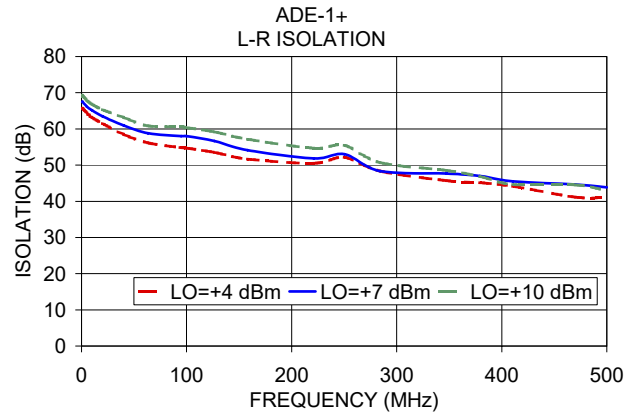
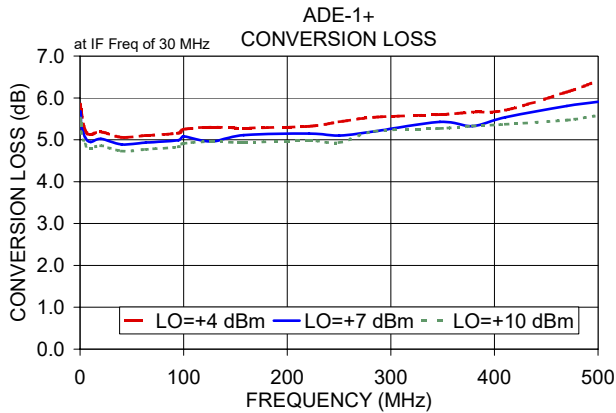

Notes

- A. Performance and quality attributes and conditions not expressly stated in this specification document are intended to be excluded and do not form a part of this specification document.
- B. Electrical specifications and performance data contained in this specification document are based on Mini-Circuit's applicable established test performance criteria and measurement instructions.
- C. The parts covered by this specification document are subject to Mini-Circuits standard limited warranty and terms and conditions (collectively, "Standard Terms"); Purchasers of this part are entitled to the rights and benefits contained therein. For a full statement of the Standard Terms and the exclusive rights and remedies thereunder, please visit Mini-Circuits' website at www.minicircuits.com/MCLStore/terms.jsp



Frequency Mixer

ADE-1+

Typical Performance Data

RF (IN) (MHz)	LO (MHz)	CONVERSION LOSS IF FIXED @IF(OUT)=30MHz (dB)			RF (IN) (MHz)	LO (MHz)	IP3 INPUT (dBm)			RF (IN) (MHz)	LO (MHz)	COMPRESSION @RF IN=+1dBm (dB)		
		@LO (dBm)					@LO (dBm)					@LO (dBm)		
		+4	+7	+10			+4	+7	+10			+4	+7	+10
0.5	30.5	5.85	5.68	5.52	10.1	40.1	16.73	26.25	26.32	10.1	40.1	1.36	1.06	0.83
0.8	30.8	5.71	5.55	5.38	30.1	60.1	21.76	23.53	22.13	30.1	60.1	1.38	1.05	0.82
1.0	31.0	5.69	5.35	5.18	50.1	80.1	21.16	18.27	26.58	50.1	80.1	1.05	1.04	0.83
5.0	35.0	5.22	5.06	4.89	70.1	100.1	21.80	21.99	20.94	70.1	100.1	1.37	0.94	0.77
10.1	40.1	5.12	4.95	4.79	90.1	120.1	23.95	19.81	18.98	90.1	120.1	1.26	0.92	0.75
30.1	60.1	5.18	4.85	4.79	110.1	140.1	18.24	18.96	17.77	110.1	140.1	1.20	0.91	0.69
50.1	80.1	5.21	4.91	4.84	130.1	160.1	20.30	17.78	16.74	130.1	160.1	1.22	0.91	0.73
70.1	100.1	5.17	4.99	4.87	150.1	180.1	26.34	16.58	13.59	150.1	180.1	1.19	0.93	0.71
90.1	120.1	5.23	5.01	4.88	170.1	200.1	23.92	17.31	15.80	170.1	200.1	1.14	0.88	0.70
110.1	140.1	5.26	5.02	4.89	190.1	220.1	14.04	13.07	14.55	190.1	220.1	1.10	0.85	0.71
130.1	160.1	5.25	5.05	4.93	210.1	240.1	13.29	11.75	12.26	210.1	240.1	1.11	0.87	0.69
150.1	180.1	5.32	5.11	4.97	230.1	260.1	15.78	13.53	15.23	230.1	260.1	1.13	0.88	0.72
170.1	200.1	5.35	5.13	4.99	250.1	280.1	14.16	14.41	18.30	250.1	280.1	1.09	0.88	0.71
190.1	220.1	5.36	5.13	5.00	270.1	300.1	12.70	12.80	17.27	270.1	300.1	1.06	0.85	0.71
210.1	240.1	5.36	5.14	5.02	290.1	320.1	12.67	12.69	14.04	290.1	320.1	1.10	0.86	0.71
230.1	260.1	5.43	5.19	5.03	310.1	340.1	12.68	12.46	13.70	310.1	340.1	1.16	0.89	0.75
250.1	280.1	5.53	5.23	5.04	330.1	360.1	12.88	12.68	14.37	330.1	360.1	1.26	1.00	0.83
290.1	320.1	5.61	5.38	5.20	350.1	380.1	13.41	12.14	14.28	350.1	380.1	1.38	1.08	0.88
310.1	340.1	5.62	5.41	5.26	370.1	400.1	13.68	14.71	15.83	370.1	400.1	1.52	1.15	0.93
330.1	360.1	5.65	5.41	5.25	390.1	420.1	12.91	14.81	16.86	390.1	420.1	1.63	1.25	0.98
350.1	380.1	5.66	5.38	5.21	410.1	440.1	9.47	14.16	17.89	410.1	440.1	1.72	1.37	1.09
370.1	400.1	5.67	5.37	5.21	430.1	460.1	6.29	9.96	16.09	430.1	460.1	1.85	1.53	1.26
390.1	420.1	5.76	5.41	5.27	450.1	480.1	5.00	7.35	12.63	450.1	480.1	1.86	1.57	1.33
410.1	440.1	5.97	5.58	5.38	470.1	500.1	4.08	5.93	9.15	470.1	500.1	1.89	1.63	1.46
450.1	480.1	6.36	5.92	5.56	510.1	540.1	4.11	5.19	6.96	510.1	540.1	1.97	1.75	1.62
470.1	500.1	6.47	6.05	5.64	530.1	560.1	4.02	5.10	6.89	530.1	560.1	1.95	1.80	1.66
510.1	540.1	6.82	6.37	5.96	570.1	600.1	5.65	7.76	12.50	570.1	600.1	1.97	1.83	1.64
530.1	560.1	6.95	6.49	6.06	590.1	620.1	7.01	9.84	19.98	590.1	620.1	1.95	1.77	1.60
570.1	600.1	7.04	6.45	5.98	630.1	660.1	9.81	15.42	13.56	630.1	660.1	1.98	1.63	1.48
590.1	620.1	7.01	6.43	5.95	650.1	680.1	10.47	13.29	14.57	650.1	680.1	1.91	1.59	1.39
650.1	680.1	7.01	6.47	6.14	690.1	720.1	10.54	12.28	13.62	690.1	720.1	1.84	1.49	1.27
690.1	720.1	7.23	6.76	6.51	710.1	740.1	10.17	11.76	12.15	710.1	740.1	1.71	1.42	1.22
750.1	780.1	7.61	7.21	7.00	750.1	780.1	10.12	10.44	10.90	750.1	780.1	1.60	1.32	1.15
770.1	800.1	7.80	7.43	7.26	770.1	800.1	9.91	9.71	10.12	770.1	800.1	1.51	1.22	1.03
810.1	840.1	8.29	8.00	7.90	810.1	840.1	9.47	9.66	10.46	810.1	840.1	1.40	1.03	0.83
830.1	860.1	8.61	8.32	8.24	830.1	860.1	9.38	9.80	12.02	830.1	860.1	1.34	0.93	0.74
870.1	900.1	9.42	9.10	8.99	870.1	900.1	10.57	13.11	14.50	870.1	900.1	1.27	0.85	0.68
890.1	920.1	9.86	9.48	9.35	890.1	920.1	10.15	13.15	14.50	890.1	920.1	1.27	0.84	0.68
930.1	960.1	10.71	10.25	10.07	930.1	960.1	10.32	13.90	14.16	930.1	960.1	1.28	0.83	0.72
950.1	980.1	11.18	10.70	10.51	950.1	980.1	10.84	14.37	15.76	950.1	980.1	1.31	0.84	0.74

REV. X2
ADE-1+
100817
Page 1 of 5



IF/RF MICROWAVE COMPONENTS • ISO 9001 ISO 14001 AS 9100 CERTIFIED • RoHS compliant
P.O. Box 350166, Brooklyn, New York 11235-0006 (718) 934-4500 Fax (718) 332-4661



The Design Engineers Search Engine finds the model you need, Instantly • For detailed performance specs & shopping online see



Frequency Mixer

ADE-1+

Typical Performance Data

IF (OUT) (MHz)	LO (MHz)	CONVERSION LOSS VS. IF FREQUENCY @RF(IN)=250.1MHz (dB)	IF (OUT) (MHz)	LO (MHz)	CONVERSION LOSS VS. IF FREQUENCY @RF(IN)=10.1MHz (dB)	IF (OUT) (MHz)	LO (MHz)	CONVERSION LOSS VS. IF FREQUENCY @RF(IN)=500.1MHz (dB)
		@LO (dBm)			@LO (dBm)			@LO (dBm)
		+7			+7			+7
240.0	10.1	5.29	10.0	20.1	4.84	490.0	10.1	5.96
234.1	16.0	5.28	22.3	32.4	4.85	477.7	22.4	5.89
228.2	21.9	5.19	34.6	44.7	4.86	465.4	34.7	5.84
222.3	27.8	5.19	46.9	57.0	4.87	453.1	47.0	5.85
216.4	33.7	5.17	59.2	69.3	4.80	440.8	59.3	5.90
210.5	39.6	5.14	71.5	81.6	4.78	428.5	71.6	5.85
204.6	45.5	5.16	83.8	93.9	4.79	416.2	83.9	5.84
198.7	51.4	5.10	96.2	106.3	4.80	403.8	96.3	5.81
192.8	57.3	5.12	108.5	118.6	4.79	391.5	108.6	5.79
186.9	63.2	5.09	120.8	130.9	4.79	379.2	120.9	5.81
181.0	69.1	5.11	133.1	143.2	4.81	366.9	133.2	5.85
175.1	75.0	5.13	145.4	155.5	4.87	354.6	145.5	5.82
169.2	80.9	5.12	157.7	167.8	4.89	342.3	157.8	5.82
163.3	86.8	5.13	170.0	180.1	4.92	330.0	170.1	5.84
157.4	92.7	5.14	182.3	192.4	4.91	317.7	182.4	5.86
151.5	98.6	5.12	194.6	204.7	4.92	305.4	194.7	5.87
145.6	104.5	5.13	206.9	217.0	4.94	293.1	207.0	5.84
139.7	110.4	5.13	219.2	229.3	4.96	280.8	219.3	5.83
133.8	116.3	5.12	231.5	241.6	4.97	268.5	231.6	5.87
127.9	122.2	5.09	243.8	253.9	4.95	256.2	243.9	5.89
122.1	128.0	5.09	256.2	266.3	4.98	243.8	256.3	5.91
116.2	133.9	5.11	268.5	278.6	4.99	231.5	268.6	5.90
110.3	139.8	5.11	280.8	290.9	5.03	219.2	280.9	5.86
104.4	145.7	5.12	293.1	303.2	5.11	206.9	293.2	5.89
98.5	151.6	5.12	305.4	315.5	5.13	194.6	305.5	5.87
92.6	157.5	5.12	317.7	327.8	5.20	182.3	317.8	5.85
86.7	163.4	5.12	330.0	340.1	5.19	170.0	330.1	5.87
80.8	169.3	5.14	342.3	352.4	5.16	157.7	342.4	5.86
74.9	175.2	5.13	354.6	364.7	5.18	145.4	354.7	5.85
69.0	181.1	5.14	366.9	377.0	5.15	133.1	367.0	5.81
63.1	187.0	5.12	379.2	389.3	5.08	120.8	379.3	5.74
57.2	192.9	5.12	391.5	401.6	5.03	108.5	391.6	5.69
51.3	198.8	5.13	403.8	413.9	5.00	96.2	403.9	5.68
45.4	204.7	5.14	416.2	426.3	5.01	83.8	416.3	5.64
39.5	210.6	5.16	428.5	438.6	5.06	71.5	428.6	5.65
33.6	216.5	5.16	440.8	450.9	5.13	59.2	440.9	5.71
27.7	222.4	5.16	453.1	463.2	5.16	46.9	453.2	5.79
21.8	228.3	5.18	465.4	475.5	5.17	34.6	465.5	5.91
15.9	234.2	5.19	477.7	487.8	5.17	22.3	477.8	6.01
10.0	240.1	5.24	490.0	500.1	5.18	10.0	490.1	6.18

REV. X2
ADE-1+
100817
Page 2 of 5



IF/RF MICROWAVE COMPONENTS • ISO 9001 ISO 14001 AS 9100 CERTIFIED • RoHS compliant
P.O. Box 350166, Brooklyn, New York 11235-0006 (718) 934-4500 Fax (718) 332-4661



The Design Engineers Search Engine finds the model you need, Instantly • For detailed performance specs & shopping online see



Typical Performance Data

LO (MHz)	LO-RF ISOLATION (dB)			LO-IF ISOLATION (dB)		
	@LO (dBm)			@LO (dBm)		
	+4	+7	+10	+4	+7	+10
0.5	65.51	67.49	69.34	59.66	56.67	55.50
0.8	65.50	67.50	69.00	59.84	56.83	55.34
1.0	65.66	67.51	69.17	59.50	56.67	55.34
5.0	64.33	66.17	67.84	58.16	55.50	54.00
10.1	63.17	65.14	66.84	57.00	54.17	52.84
30.1	61.42	63.14	64.71	65.38	64.59	62.11
50.1	58.65	60.39	62.34	59.34	59.76	57.83
70.1	56.11	57.91	59.58	56.65	55.35	54.10
90.1	53.98	56.09	58.02	53.97	52.69	51.87
110.1	52.88	55.03	56.90	50.91	50.03	50.24
130.1	52.09	54.50	56.58	48.87	48.71	48.77
150.1	50.80	52.93	54.71	47.19	47.41	47.53
190.1	49.41	51.80	53.79	44.78	45.30	45.95
210.1	48.36	50.38	52.36	43.51	44.10	44.68
230.1	48.29	50.36	52.21	42.87	43.57	43.62
250.1	47.82	49.68	51.30	42.46	43.68	43.63
270.1	48.84	51.24	53.31	41.45	42.36	42.46
290.1	48.69	51.34	53.26	41.23	41.79	41.55
310.1	47.04	49.81	52.26	41.01	40.88	39.93
350.1	44.50	46.74	48.75	38.80	38.74	38.02
370.1	42.38	44.30	46.04	38.62	37.60	36.30
390.1	41.57	43.82	46.36	37.38	36.18	34.66
410.1	41.10	43.35	45.28	35.79	33.84	32.49
450.1	39.95	42.32	44.15	35.42	32.30	30.45
470.1	39.60	41.70	43.46	35.74	31.87	29.42
510.1	40.78	42.73	43.99	35.23	31.77	28.27
530.1	41.49	43.75	44.90	34.92	31.75	28.55
570.1	41.22	42.71	42.14	34.41	30.83	27.54
590.1	39.71	39.77	39.06	33.70	29.53	26.11
650.1	38.21	37.15	36.10	31.60	26.22	23.32
690.1	37.60	36.10	34.81	28.18	24.05	21.46
710.1	37.96	35.31	33.26	26.46	22.79	20.47
750.1	37.68	33.37	30.96	23.63	20.79	18.90
770.1	36.35	32.11	29.59	22.14	19.86	17.97
810.1	32.57	28.90	26.57	19.87	18.28	16.62
830.1	31.16	27.56	25.35	18.99	17.63	16.14
870.1	27.76	25.07	23.04	17.44	16.66	15.34
890.1	25.98	23.66	21.76	16.55	16.15	14.92
930.1	23.96	22.03	20.33	15.35	15.39	14.49
950.1	22.97	21.12	19.60	14.81	15.00	14.25

RF (IN) (MHz)	LO (MHz)	RF-IF ISOLATION (dB)		
		@LO (dBm)		
		+4	+7	+10
10.1	40.1	42.08	42.42	45.59
30.1	60.1	35.36	34.69	35.75
50.1	80.1	31.34	30.85	31.08
70.1	100.1	28.45	28.69	28.81
90.1	120.1	26.75	26.93	27.14
110.1	140.1	25.48	25.70	25.78
130.1	160.1	24.46	24.60	24.70
150.1	180.1	23.62	23.78	24.01
170.1	200.1	23.33	23.60	23.73
190.1	220.1	22.98	23.39	23.57
210.1	240.1	22.65	23.00	23.31
230.1	260.1	22.61	23.05	23.43
250.1	280.1	22.68	23.12	23.48
270.1	300.1	22.90	23.21	23.61
290.1	320.1	23.58	23.89	24.22
310.1	340.1	24.11	24.66	25.09
330.1	360.1	24.61	25.46	26.32
350.1	380.1	24.02	25.13	26.06
370.1	400.1	23.26	24.28	25.00
390.1	420.1	22.01	22.76	23.19
410.1	440.1	20.46	20.79	21.01
430.1	460.1	19.51	19.67	19.68
450.1	480.1	18.73	18.81	18.72
470.1	500.1	18.26	18.29	18.25
510.1	540.1	18.10	18.19	18.45
530.1	560.1	18.24	18.42	18.81
570.1	600.1	18.87	19.06	19.24
590.1	620.1	18.80	18.69	18.53
630.1	660.1	17.89	17.35	16.91
650.1	680.1	17.17	16.71	16.47
690.1	720.1	15.89	15.63	15.38
710.1	740.1	15.29	14.98	14.69
750.1	780.1	14.03	13.69	13.26
770.1	800.1	13.19	12.87	12.41
810.1	840.1	11.59	11.26	10.75
830.1	860.1	10.83	10.44	9.94
870.1	900.1	9.46	8.95	8.48
890.1	920.1	8.78	8.34	7.83
930.1	960.1	7.76	7.29	6.89
950.1	980.1	7.26	6.79	6.44

Frequency Mixer

ADE-1+

Typical Performance Data

RF (IN) (MHz)	LO (MHz)	RF VSWR (:1)		
		@LO (dBm)		
		+4	+7	+10
0.5	30.5	1.50	1.46	1.45
0.8	30.8	1.38	1.32	1.30
1.0	31.0	1.34	1.29	1.26
5.0	35.0	1.29	1.19	1.12
10.1	40.1	1.29	1.18	1.11
30.1	60.1	1.23	1.15	1.06
50.1	80.1	1.23	1.13	1.07
70.1	100.1	1.19	1.11	1.06
90.1	120.1	1.20	1.10	1.05
110.1	140.1	1.17	1.08	1.03
150.1	180.1	1.17	1.09	1.04
170.1	200.1	1.15	1.06	1.03
190.1	220.1	1.13	1.06	1.04
210.1	240.1	1.12	1.04	1.03
250.1	280.1	1.11	1.05	1.07
270.1	300.1	1.12	1.06	1.08
290.1	320.1	1.11	1.08	1.10
310.1	340.1	1.09	1.09	1.12
350.1	380.1	1.09	1.15	1.20
370.1	400.1	1.10	1.17	1.22
390.1	420.1	1.10	1.17	1.21
410.1	440.1	1.09	1.13	1.18
450.1	480.1	1.17	1.12	1.14
470.1	500.1	1.23	1.17	1.17
510.1	540.1	1.42	1.37	1.33
530.1	560.1	1.54	1.48	1.43
570.1	600.1	1.79	1.71	1.66
590.1	620.1	1.89	1.83	1.78
630.1	660.1	2.16	2.10	2.07
650.1	680.1	2.32	2.26	2.22
690.1	720.1	2.65	2.60	2.55
710.1	740.1	2.80	2.73	2.68
750.1	780.1	2.96	2.88	2.81
770.1	800.1	3.04	2.94	2.86
810.1	840.1	3.18	3.06	2.96
830.1	860.1	3.25	3.11	3.00
870.1	900.1	3.33	3.15	3.03
890.1	920.1	3.35	3.15	3.02
930.1	960.1	3.35	3.12	3.00
950.1	980.1	3.31	3.09	2.96

LO (MHz)	LO VSWR (:1)		
	@LO (dBm)		
	+4	+7	+10
0.5	1.69	2.51	3.46
0.8	1.67	2.56	3.57
1.0	1.71	2.56	3.57
5.0	1.67	2.51	3.46
10.1	1.69	2.51	3.46
30.1	1.77	2.64	3.77
50.1	1.75	2.60	3.68
70.1	1.67	2.41	3.37
90.1	1.66	2.37	3.30
110.1	1.69	2.46	3.47
150.1	1.75	2.54	3.52
170.1	1.72	2.46	3.39
190.1	1.73	2.47	3.40
210.1	1.81	2.58	3.56
250.1	1.85	2.62	3.58
270.1	1.87	2.60	3.52
290.1	1.90	2.66	3.60
310.1	1.97	2.77	3.76
350.1	2.02	2.78	3.74
370.1	2.03	2.77	3.70
390.1	2.10	2.84	3.79
410.1	2.21	2.96	3.94
450.1	2.35	3.11	4.04
470.1	2.40	3.18	4.12
510.1	2.54	3.39	4.40
530.1	2.57	3.40	4.41
570.1	2.61	3.42	4.41
590.1	2.66	3.48	4.47
630.1	2.71	3.47	4.42
650.1	2.71	3.45	4.39
690.1	2.80	3.56	4.53
710.1	2.88	3.62	4.57
750.1	3.07	3.74	4.63
770.1	3.21	3.86	4.73
810.1	3.54	4.09	4.87
830.1	3.71	4.18	4.89
870.1	4.06	4.41	5.00
890.1	4.21	4.50	5.03
930.1	4.41	4.61	5.04
950.1	4.43	4.63	5.03

IF (OUT) (MHz)	IF VSWR @LO=500.1MHz (:1)		
	@LO (dBm)		
	+4	+7	+10
0.1	2.17	1.74	1.49
0.3	2.13	1.74	1.49
0.5	2.20	1.78	1.52
0.8	2.28	1.85	1.55
1.0	2.28	1.85	1.55
5.0	2.24	1.81	1.54
10.0	2.33	1.95	1.75
22.6	2.28	1.97	1.69
35.1	2.19	1.83	1.57
47.7	2.17	1.83	1.55
60.3	2.15	1.82	1.52
85.4	2.19	1.87	1.57
97.9	2.18	1.86	1.58
110.5	2.19	1.87	1.59
123.1	2.19	1.89	1.60
135.6	2.19	1.88	1.59
148.2	2.14	1.85	1.58
173.3	2.12	1.83	1.59
185.9	2.13	1.84	1.60
198.5	2.15	1.87	1.63
211.0	2.15	1.88	1.64
223.6	2.15	1.88	1.65
236.2	2.13	1.87	1.65
248.7	2.13	1.87	1.65
273.8	2.15	1.88	1.67
286.4	2.10	1.86	1.66
299.0	2.06	1.83	1.64
311.5	2.05	1.81	1.62
324.1	2.05	1.82	1.64
336.7	2.04	1.83	1.66
349.2	2.05	1.83	1.67
374.4	2.03	1.82	1.66
386.9	2.01	1.79	1.65
399.5	2.00	1.79	1.63
424.6	1.96	1.78	1.65
437.2	1.96	1.76	1.64
449.7	1.98	1.78	1.64
474.9	1.99	1.80	1.67
487.4	2.00	1.79	1.65
500.0	2.18	2.08	2.06

REV. X2
ADE-1+
100817
Page 4 of 5



IF/RF MICROWAVE COMPONENTS • ISO 9001 ISO 14001 AS 9100 CERTIFIED • RoHS compliant
P.O. Box 350166, Brooklyn, New York 11235-0003 (718) 934-4500 Fax (718) 332-4661



The Design Engineers Search Engine finds the model you need, Instantly • For detailed performance specs & shopping online see



Harmonics Tables

RF HARMONICS ORDER

	(-dBm)	(-dBc)										
0	-	-	16	37	12	35	12	46	19	40	33	53
1	-	18	+0	25	11	38	22	37	36	49	46	44
2	106	73	51	79	52	83	50	65	50	66	53	80
3	116	72	63	74	62	77	61	78	81	80	73	84
4	109	95	98	96	87	89	86	105	91	102	91	99
5	112	110	95	92	86	86	88	101	87	102	98	103
6	133	98	98	104	98	90	94	86	100	101	102	96
7	121	96	102	104	100	102	99	83	90	98	100	96
8	115	99	99	102	102	93	106	114	78	99	100	102
9	120	114	107	102	100	101	94	101	92	66	107	93
10	113	105	105	104	104	110	97	93	95	89	81	88
	RF CAL	0	1	2	3	4	5	6	7	8	9	10

LO HARMONICS ORDER

Test conditions: RF IN: 250.1 MHz; -14.00 dBm.
 LO IN: 280.01 MHz; +7.00 dBm
 IF OUT: 29.91 MHz; -19.35 dBm

RF HARMONICS ORDER

	(-dBm)	(-dBc)										
0	-	-	24	51	23	46	24	55	31	52	49	65
1	-	19	+0	27	12	41	24	43	38	54	55	57
2	102	63	43	71	45	62	44	57	44	61	49	66
3	107	45	42	47	44	48	38	50	47	54	54	69
4	111	76	67	72	64	73	64	77	59	69	58	70
5	119	67	64	59	52	66	51	65	51	66	66	73
6	112	89	84	107	81	91	80	94	82	78	80	82
7	110	92	83	85	73	70	71	69	68	69	63	71
8	113	94	109	95	95	94	89	88	83	88	83	87
9	111	86	107	102	88	90	75	82	77	70	76	92
10	110	101	104	102	101	104	96	97	93	95	83	96
	RF CAL	0	1	2	3	4	5	6	7	8	9	10

LO HARMONICS ORDER

Test conditions: RF IN: 250.1 MHz; -4.00 dBm.
 LO IN: 280.01 MHz; +7.00 dBm
 IF OUT: 29.91 MHz; -9.37 dBm

- Notes: 1. All Harmonics are in (dBc) relative to IF OUTPUT.
 2. + entry denotes harmonics are in (dBc) above IF OUTPUT.
 3. RF Cal represent the Harmonics level of the RF input signal to the mixer.

REV. X2
 ADE-1+
 100817

Page 5 of 5



IF/RF MICROWAVE COMPONENTS • ISO 9001 ISO 14001 AS 9100 CERTIFIED • RoHS compliant
 P.O. Box 350166, Brooklyn, New York 11235-0006 (718) 934-4500 Fax (718) 332-4661



The Design Engineers Search Engine finds the model you need, Instantly • For detailed performance specs & shopping online see [minicircuits.com](http://www.minicircuits.com)

Typical Performance Curves

Conversion Loss @ IF=30MHz

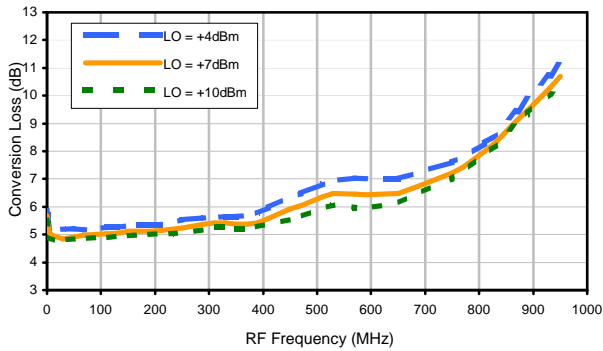

Conversion Loss vs. IF @ RF=250.1MHz

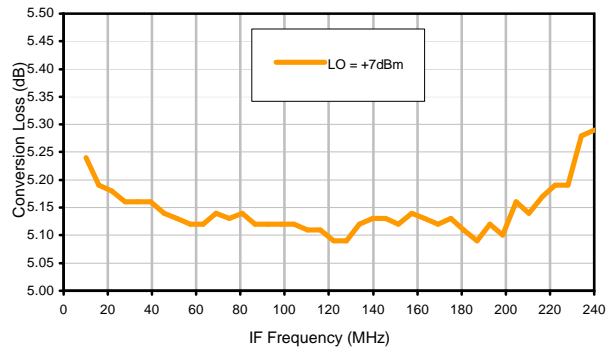

Conversion Loss vs. IF @ RF=10.1MHz

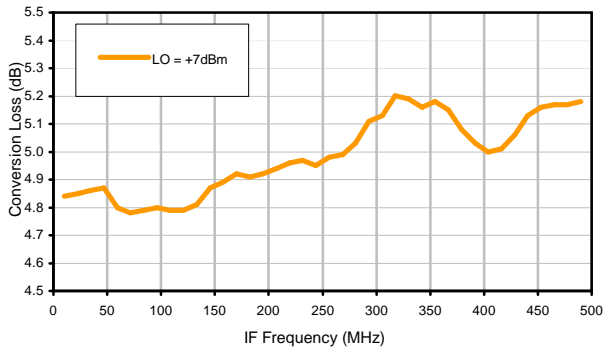

Conversion Loss vs. IF @ RF=500.1MHz

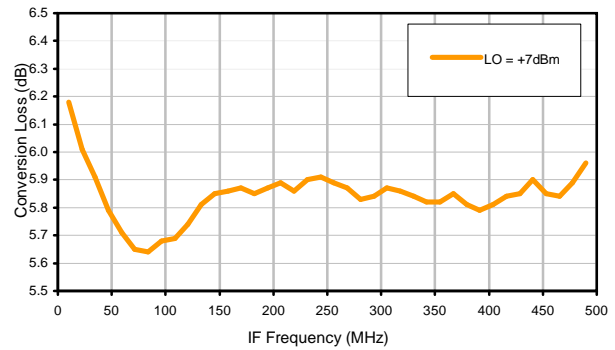

IP3 Input

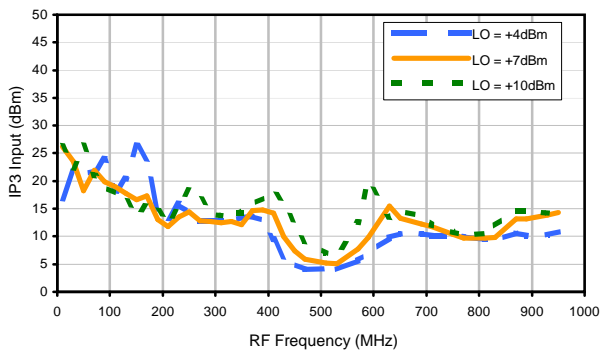

Compression @ RF IN=+1dBm

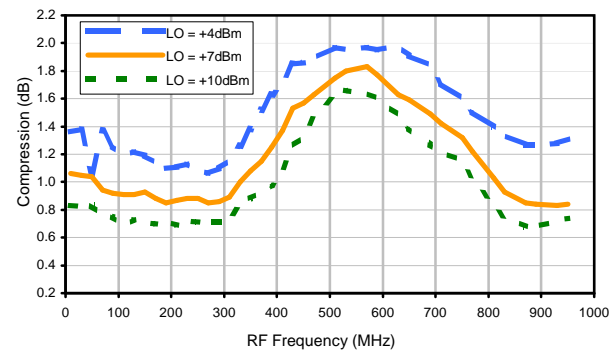

Typical Performance Curves

LO-RF Isolation

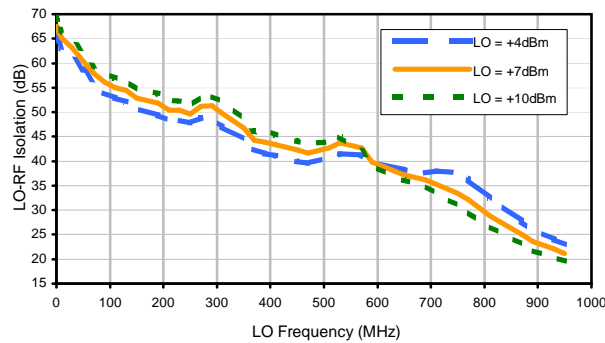

LO-IF Isolation

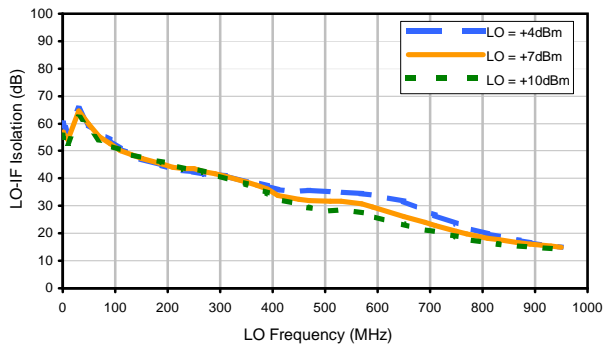

RF-IF Isolation

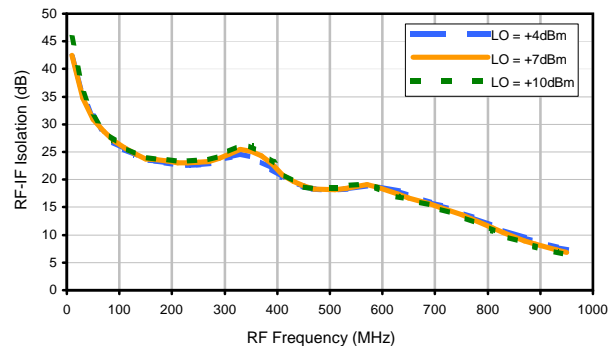

RF VSWR

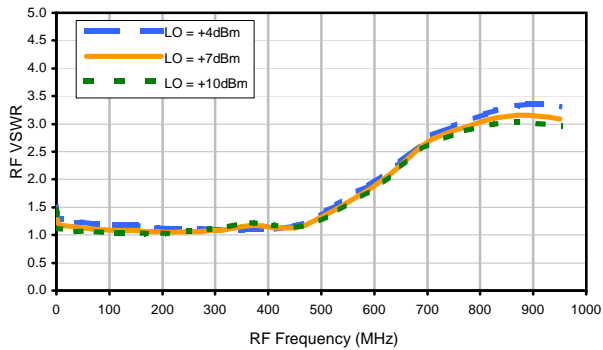

LO VSWR

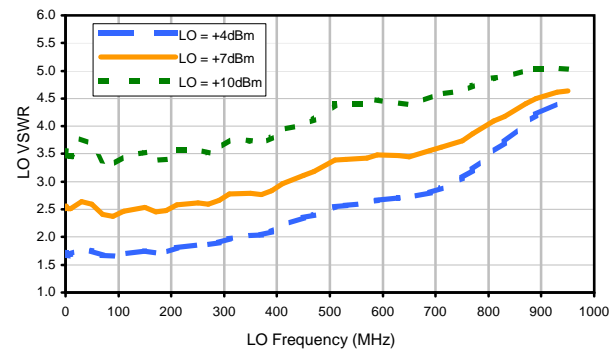

IF VSWR

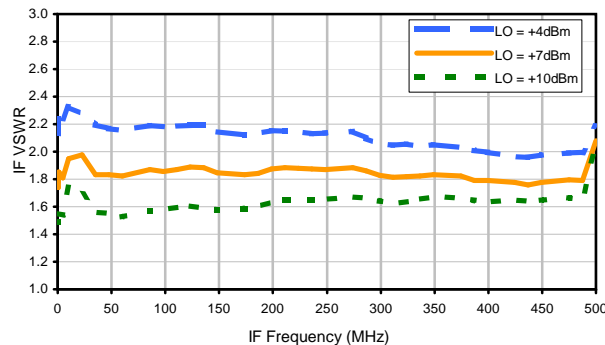

Harmonics Tables

RF HARMONICS ORDER

	(-dBm)	(-dBc)										
0	-	-	16	37	12	35	12	46	19	40	33	53
1	-	18	+0	25	11	38	22	37	36	49	46	44
2	106	73	51	79	52	83	50	65	50	66	53	80
3	116	72	63	74	62	77	61	78	81	80	73	84
4	109	95	98	96	87	89	86	105	91	102	91	99
5	112	110	95	92	86	86	88	101	87	102	98	103
6	133	98	98	104	98	90	94	86	100	101	102	96
7	121	96	102	104	100	102	99	83	90	98	100	96
8	115	99	99	102	102	93	106	114	78	99	100	102
9	120	114	107	102	100	101	94	101	92	66	107	93
10	113	105	105	104	104	110	97	93	95	89	81	88
	RF CAL	0	1	2	3	4	5	6	7	8	9	10

LO HARMONICS ORDER

Test conditions: RF IN: 250.1 MHz; -14.00 dBm.
 LO IN: 280.01 MHz; +7.00 dBm
 IF OUT: 29.91 MHz; -19.35 dBm

RF HARMONICS ORDER

	(-dBm)	(-dBc)										
0	-	-	24	51	23	46	24	55	31	52	49	65
1	-	19	+0	27	12	41	24	43	38	54	55	57
2	102	63	43	71	45	62	44	57	44	61	49	66
3	107	45	42	47	44	48	38	50	47	54	54	69
4	111	76	67	72	64	73	64	77	59	69	58	70
5	119	67	64	59	52	66	51	65	51	66	66	73
6	112	89	84	107	81	91	80	94	82	78	80	82
7	110	92	83	85	73	70	71	69	68	69	63	71
8	113	94	109	95	95	94	89	88	83	88	83	87
9	111	86	107	102	88	90	75	82	77	70	76	92
10	110	101	104	102	101	104	96	97	93	95	83	96
	RF CAL	0	1	2	3	4	5	6	7	8	9	10

LO HARMONICS ORDER

Test conditions: RF IN: 250.1 MHz; -4.00 dBm.
 LO IN: 280.01 MHz; +7.00 dBm
 IF OUT: 29.91 MHz; -9.37 dBm

- Notes: 1. All Harmonics are in (dBc) relative to IF OUTPUT.
 2. + entry denotes harmonics are in (dBc) above IF OUTPUT.
 3. RF Cal represent the Harmonics level of the RF input signal to the mixer.

REV. X2
 ADE-1+
 100817

Page 3 of 3



IF/RF MICROWAVE COMPONENTS • ISO 9001 ISO 14001 AS 9100 CERTIFIED • RoHS compliant
 P.O. Box 350166, Brooklyn, New York 11235-0006 (718) 934-4500 Fax (718) 332-4661



The Design Engineers Search Engine finds the model you need, Instantly • For detailed performance specs & shopping online see



Case Style

CD

CD541
CD542
CD636
CD637

Outline Dimensions



PCB Land Pattern



Suggested Layout,
Tolerance to be within $\pm .002$

CASE#	A	B	C	D	E	F	G	H	J	K	L	WT, GRAM
CD541					.082 (2.08)							.15
CD542	.272 (6.91)	.310 (7.87)	.220 (5.58)	.100 (2.54)	.112 (2.84)	.055 (1.40)	.100 (2.54)	.030 (0.76)	.026 (0.66)	.065 (1.65)	.300 (7.62)	.20
CD636					.162 (4.11)							.25
CD637					.206 (5.23)							.40

Dimensions are in inches (mm). Tolerances: 2 Pl. $\pm .01$; 3 Pl. $\pm .005$

Notes:

- Case material: Plastic.
- Termination finish:
For RoHS Case Styles: Tin plate over Nickel plate. All models, (+) suffix.
For RoHS-5 Case Styles: Tin-Lead plate. All models, no (+) suffix.

Mini-Circuits®

INTERNET <http://www.minicircuits.com>

P.O. Box 350166, Brooklyn, New York 11235-0003 (718) 934-4500 Fax (718) 332-4661

Distribution Centers NORTH AMERICA 800-654-7949 • 417-335-5935 • Fax 417-335-5945 • EUROPE 44-1252-832600 • Fax 44-1252-837010

Mini-Circuits ISO 9001 & ISO 14001 Certified

Tape & Reel Packaging TR-F34



Tape Width, mm	Device Cavity Pitch, mm	Reel Size, inches	Devices per Reel see note	
16	12	7	Small quantity standard (see note)	20
				50
				100
				200
		13	Standard	500
1000				

Note: Availability of small reel quantity varies by model.
Refer to pricing and availability on individual model dashboard.

Mini-Circuits carrier tape materials provide protection from ESD (Electro-Static Discharge) during handling and transportation. Tapes are static dissipative and comply with industry standards EIA-481/EIA-541.

Go to: www.minicircuits.com/pages/pdfs/tape.pdf



INTERNET <http://www.minicircuits.com>

P.O. Box 350166, Brooklyn, New York 11235-0003 (718) 934-4500 Fax (718) 332-4661

Distribution Centers NORTH AMERICA 800-654-7949 • 417-335-5935 • Fax 417-335-5945 • EUROPE 44-1252-832600 • Fax 44-1252-837010

Mini-Circuits ISO 9001 & ISO 14001 Certified

THIRD ANGLE PROJECTION



REVISIONS

REV	ECN No.	DESCRIPTION	DATE	DR	AUTH
A	M101143	ADDED "gk" PIN CONNECTION, TT100 CASE STYLE & NOTE 2	10/10/05	MMG	DJ
B	M102713	ADDED "...WITH SMOBC"	01/17/06	MMG	IL
C	M108637	REMOVED "PIN 1", ADDED INDEX ON UNIT	12/01/06	MYG	FL

SUGGESTED MOUNTING CONFIGURATION
FOR BH292, CD541/542/636/637, TT100/240 CASE
STYLES, "gk", "ht", "hu", "nd", "w" PIN CONNECTIONS



- NOTES:** 1. TRACE WIDTH IS SHOWN FOR ROGERS R04350B WITH DIELECTRIC THICKNESS .030" ± .002"; COPPER: 1/2 OZ. EACH SIDE. FOR OTHER MATERIALS TRACE WIDTH MAY NEED TO BE MODIFIED.
 2. BOTTOM SIDE OF THE PCB IS CONTINUOUS GROUND PLANE.

- DENOTES PCB COPPER LAYOUT WITH SMOBC (SOLDER MASK OVER BARE COPPER)
- DENOTES COPPER LAND PATTERN FREE OF SOLDER MASK

UNLESS OTHERWISE SPECIFIED	INITIALS	DATE
DIMENSIONS ARE IN INCHES	MMG	07/17/02
TOLERANCES ON:	WL	08/02/02
2 PL DECIMALS ±	DJ	08/05/02
3 PL DECIMALS ± .005		
ANGLES ±		
FRACTIONS ±		

Mini-Circuits® 13 Neptune Avenue
 Brooklyn NY 11235

PL, gk/ht/hu/nd/w, BH292,
 CD541/542/636/637, TT100/240, TB-03

SIZE A	CODE IDENT 15542	DRAWING NO: 98-PL-052	REV: C
FILE: 98PL052	SCALE: 8:1	SHEET: 1 OF 1	

Mini-Circuits®
 THIS DOCUMENT AND ITS CONTENTS ARE THE PROPERTY OF MINI-CIRCUITS. EXCEPT FOR USE EXPRESSLY GRANTED, IN WRITING, TO ITS VENDORS, VENDEE AND THE UNITED STATES GOVERNMENT, MINI-CIRCUITS RESERVES ALL PROPRIETARY DESIGN, USE, MANUFACTURING AND REPRODUCTION RIGHTS THERETO. THESE CONTENTS SHALL NOT BE USED, DUPLICATED OR DISCLOSED TO ANY OUTSIDE PARTY, IN WHOLE OR IN PART, WITHOUT WRITTEN PERMISSION OF MINI-CIRCUITS.

THIRD ANGLE PROJECTION



REVISIONS

REV	ECN No.	DESCRIPTION	DATE	DR	AUTH
E	M119737	UPDATED PCB	10.08	MF	AD
F	M127659	UPDATED CARR	06.10	SW	SG
G	M127846	UPDATED SCHEMATIC DIAGRAM	06.10	SW	SG
H	M131840	UPDATED DWG	05.11	MF	AD



NOTES:

1. REFER TO -09 PAGE FOR ITEM DESCRIPTIONS.
DESIGNATION NUMBERS ON -20 PAGE CORRESPOND TO THE NUMBERS ON -09 PAGE.
2. FOR TEXT HEIGHT & STYLE ON THE LABEL REFER TO: D3-G209.

UNLESS OTHERWISE SPECIFIED	INITIALS		DATE
DIMENSIONS ARE IN INCHES TOLERANCES ON: 2 PL DECIMALS ± 3 PL DECIMALS ± ANGLES ± FRACTIONS ±	DRAWN	S.WOLYNSKI	06.29.99
	CHECKED	SG	07.06.99
	APPROVED	MG	07.10.99

 **Mini-Circuits®** 13 Neptune Avenue
Brooklyn NY 11235

TB,ADE,CD542/636,06MX01,50

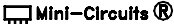
 Mini-Circuits®
THIS DOCUMENT AND ITS CONTENTS ARE THE PROPERTY OF MINI-CIRCUITS. EXCEPT FOR USE EXPRESSLY GRANTED, IN WRITING, TO ITS VENDORS, VENDEE AND THE UNITED STATES GOVERNMENT, MINI-CIRCUITS RESERVES ALL PROPRIETARY DESIGN, USE, MANUFACTURING AND REPRODUCTION RIGHTS THERETO. THESE CONTENTS SHALL NOT BE USED, DUPLICATED OR DISCLOSED TO ANY OUTSIDE PARTY, IN WHOLE OR IN PART, WITHOUT WRITTEN PERMISSION OF MINI-CIRCUITS.

SIZE A	CODE IDENT 15542	DRAWING NO: TB-03-20	REV: H
FILE: WTB-03	SCALE: 1.5:1	SHEET: 1 OF 2	

Evaluation Board and Circuit

For Pin Connections and DUT Orientation Refer to
Data Sheet of the DUT



TB-03

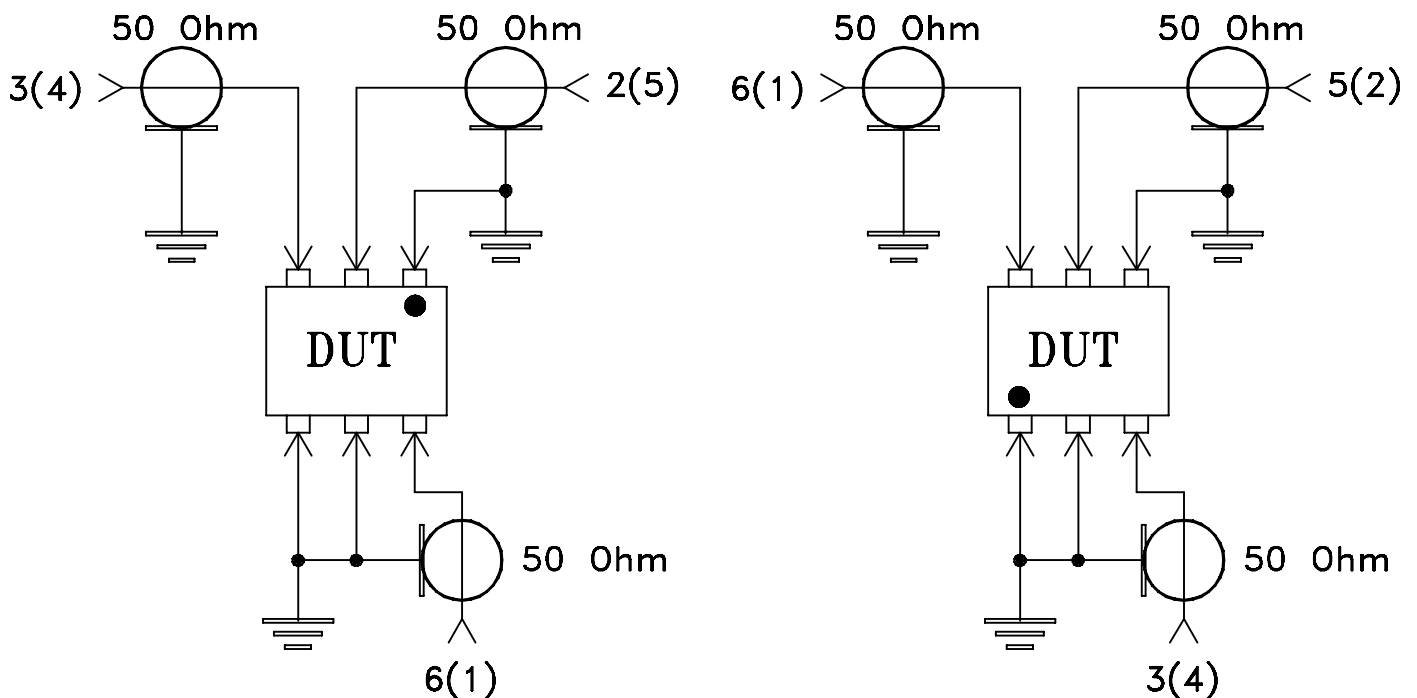

Schematic Diagram

Notes:

1. 50 Ohm SMA Female connectors.
2. PCB Material: Rogers R04350 or equivalent,
Dielectric Constant=3.5, Thickness=.030 inch.

 **Mini-Circuits®**



All Mini-Circuits products are manufactured under exacting quality assurance and control standards, and are capable of meeting published specifications after being subjected to any or all of the following physical and environmental test.

Specification	Test/Inspection Condition	Reference/Spec
Operating Temperature	-40° to 85°C Ambient Environment	Individual Model Data Sheet
Storage Temperature	-55° to 100° C Ambient Environment	Individual Model Data Sheet
Humidity	90 to 95% RH, 240 hours, 50°C	MIL-STD-202, Method 103, Condition A, Except 50°C and end-point electrical test done within 12 hours
Thermal Shock	-55° to 100°C, 100 cycles	MIL-STD-202, Method 107, Condition A-3, except +100°C
Solder Reflow Heat	Sn-Pb Eutetic Process: 225°C peak Pb-Free Process 245° - 250°C peak	J-STD-020, Table 4-1, 4-2 and 5-2, Figure 5-1
Solderability	10X Magnification	J-STD-002, 95% Coverage
Vibration (High Frequency)	20g peak, 10-2000 Hz, 12 times in each of three perpendicular directions (total 36)	MIL-STD-202, Method 204, Condition D
Mechanical Shock	50g, 11 ms, 1/2-sine, 18 shocks: 3 each direction, each of 3 axes	MIL-STD-202, Method 213, Condition A
Marking Resistance to Solvents	Isopropyl alcohol + mineral spirits at 25°C; terpene defluxer at 25°C; distilled water + proylene glycol monomethyl ether + monoethanolamine at 63°C to 70°C	MIL-STD-202, Method 215