

Surface Mount

Frequency Mixer

ADE-12

Level 7 (LO Power +7 dBm) 50 to 1000 MHz



Generic photo used for illustration purposes only
CASE STYLE: CD541

Maximum Ratings

Operating Temperature	-40°C to 85°C
Storage Temperature	-55°C to 100°C
RF Power	50mW
IF Current	40mA

Permanent damage may occur if any of these limits are exceeded.

Pin Connections

LO	6
RF	4
IF	3
GROUND	1,2,5

Outline Drawing

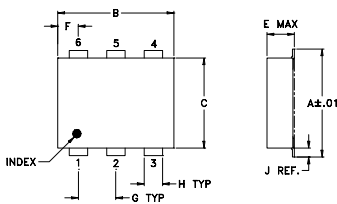

PCB Land Pattern

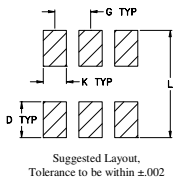

Outline Dimensions (inch/mm)

A	B	C	D	E	F	G
.272	.310	.220	.100	.082	.055	.100
6.91	7.87	5.59	2.54	2.08	1.40	2.54
H	J	K	L	wt		
.030	.026	.065	.300	grams		
0.76	0.66	1.65	7.62	0.15		

Demo Board MCL P/N: TB-02
Suggested PCB Layout (PL-051)

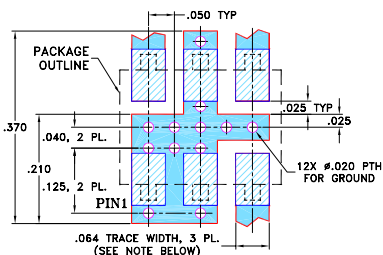

- NOTES: 1. TRACE WIDTH IS SHOWN FOR ROGERS RO4350B WITH DIELECTRIC THICKNESS .030" ± .002"; COPPER: 1/2 OZ. EACH SIDE. FOR OTHER MATERIALS TRACE WIDTH MAY NEED TO BE MODIFIED.
2. BOTTOM SIDE OF THE PCB IS CONTINUOUS GROUND PLANE.
- DENOTES PCB COPPER LAYOUT WITH SMOBC (SOLDER MASK OVER BARE COPPER)
 - DENOTES COPPER LAND PATTERN FREE OF SOLDER MASK

Notes

- A. Performance and quality attributes and conditions not expressly stated in this specification document are intended to be excluded and do not form a part of this specification document.
B. Electrical specifications and performance data contained in this specification document are based on Mini-Circuit's applicable established test performance criteria and measurement instructions.
C. The parts covered by this specification document are subject to Mini-Circuits standard limited warranty and terms and conditions (collectively, "Standard Terms"); Purchasers of this part are entitled to the rights and benefits contained therein. For a full statement of the Standard Terms and the exclusive rights and remedies thereunder, please visit Mini-Circuits' website at www.minicircuits.com/MCLStore/terms.jsp

Features

- low conversion loss, 7.0 dB typ.
- excellent IP3, 17 dBm typ.
- low profile package
- aqueous washable
- protected by U.S. Patent 6,133,525

Applications

- cellular
- VHF/UHF

Electrical Specifications

FREQUENCY (MHz)		CONVERSION LOSS (dB)				LO-RF ISOLATION (dB)				LO-IF ISOLATION (dB)				IP3 at center band (dBm)
LO/RF	IF	Mid-Band		Total	L		U		L		U		Typ.	
f_L - f_U	DC-1000	\bar{X}	σ	Max.	Range	Typ.	Min.	Typ.	Min.	Typ.	Min.	Typ.	Min.	Typ.
50-1000	DC-1000	7.0	0.15	8.0	9.0	40	25	33	22	44	26	37	20	17

1 dB COMP.: +1 dBm typ.

L = low range [f_L to 10 f_L] U = upper range [$f_U/2$ to f_U] m = mid band [$2f_L$ to $f_U/2$]

Typical Performance Data

Frequency (MHz)		Conversion Loss (dB)	Isolation L-R (dB)	Isolation L-I (dB)	VSWR RF Port (:1)	VSWR LO Port (:1)
RF	LO	LO +7dBm	LO +7dBm	LO +7dBm	LO +7dBm	LO +7dBm
50.00	80.00	7.27	51.50	46.30	2.68	1.39
70.00	100.00	7.27	49.70	44.50	2.65	1.41
80.00	110.00	7.18	48.90	43.90	2.68	1.42
100.00	130.00	7.18	47.70	42.50	2.68	1.41
117.86	147.86	7.19	46.30	41.80	2.76	1.43
185.71	215.71	7.23	43.40	39.00	2.68	1.41
253.57	283.57	7.08	41.00	37.40	2.55	1.42
321.43	351.43	7.04	39.30	35.50	2.61	1.40
389.29	419.29	6.94	37.90	35.20	2.68	1.39
457.14	487.14	6.85	37.00	34.20	2.61	1.35
500.00	530.00	6.90	36.70	33.60	2.61	1.30
525.00	555.00	6.93	36.50	33.20	2.55	1.27
592.86	622.86	6.96	35.60	33.90	2.65	1.27
660.71	690.71	6.84	35.80	34.80	2.80	1.25
728.57	758.57	6.85	35.30	34.80	2.84	1.21
796.43	826.43	6.87	34.70	37.00	2.80	1.21
800.00	830.00	6.92	34.70	37.00	2.84	1.22
864.29	894.29	6.87	34.70	36.10	3.06	1.17
932.14	962.14	6.85	34.70	28.40	3.26	1.23
1000.00	1030.00	6.91	35.60	25.60	3.44	1.26

Electrical Schematic

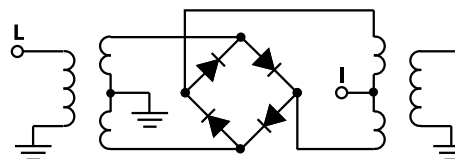

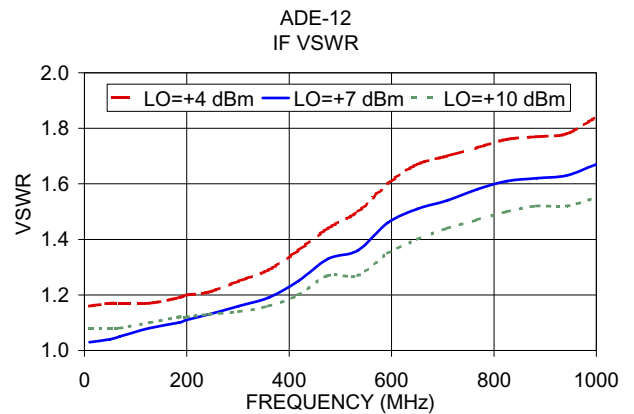
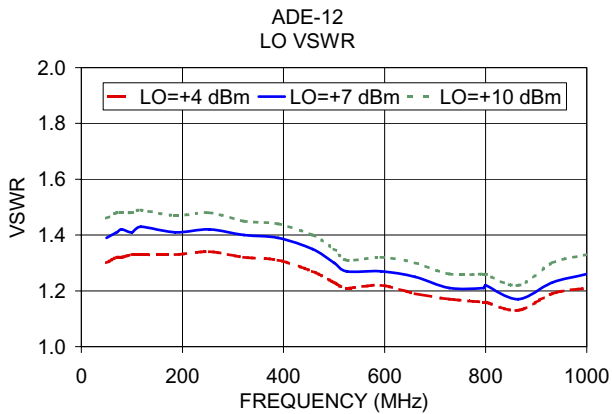
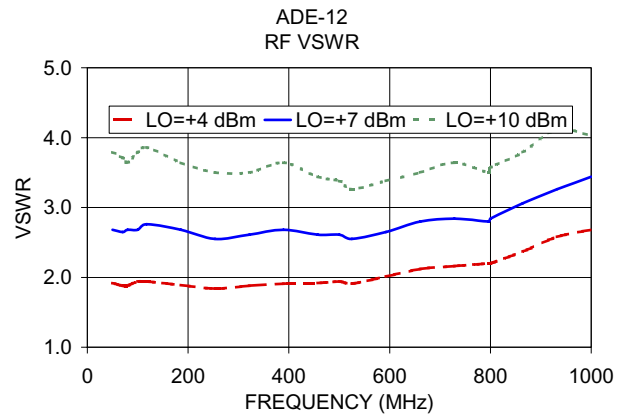
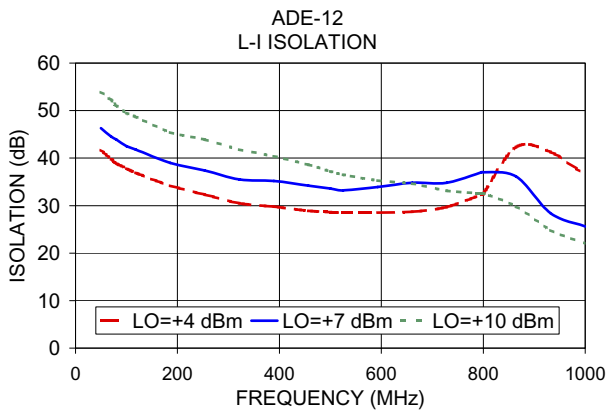
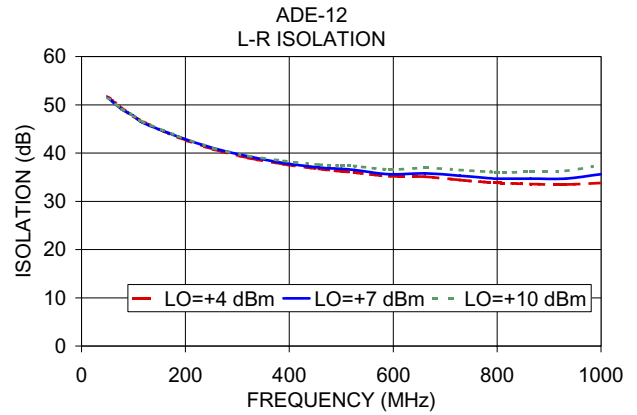
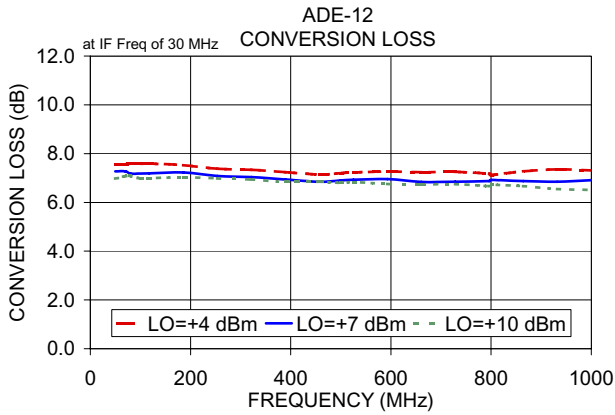

Notes

- A. Performance and quality attributes and conditions not expressly stated in this specification document are intended to be excluded and do not form a part of this specification document.
- B. Electrical specifications and performance data contained in this specification document are based on Mini-Circuit's applicable established test performance criteria and measurement instructions.
- C. The parts covered by this specification document are subject to Mini-Circuit's standard limited warranty and terms and conditions (collectively, "Standard Terms"); Purchasers of this part are entitled to the rights and benefits contained therein. For a full statement of the Standard Terms and the exclusive rights and remedies thereunder, please visit Mini-Circuit's website at www.minicircuits.com/MCLStore/terms.jsp



Frequency Mixer

ADE-12

Typical Performance Data

RF (IN) (MHz)	LO (MHz)	CONVERSION LOSS IF FIXED @IF(OUT)=30MHz (dB)			RF (IN) (MHz)	LO (MHz)	IP3 INPUT (dBm)			RF (IN) (MHz)	LO (MHz)	COMPRESSION @RF IN=+1dBm (dB)		
		@LO (dBm)					@LO (dBm)					@LO (dBm)		
		+4	+7	+10			+4	+7	+10			+4	+7	+10
50.1	80.1	7.86	7.27	6.99	50.1	80.1	14.69	18.03	19.39	50.1	80.1	0.54	0.34	0.24
90.4	120.4	7.85	7.28	6.99	90.4	120.4	14.75	16.97	19.34	90.4	120.4	0.50	0.32	0.23
130.6	160.6	7.77	7.22	6.96	130.6	160.6	15.16	22.60	20.94	130.6	160.6	0.52	0.34	0.24
170.9	200.9	7.72	7.19	6.96	170.9	200.9	15.87	18.57	20.05	170.9	200.9	0.52	0.33	0.21
211.1	241.1	7.62	7.13	6.91	211.1	241.1	16.97	17.76	22.51	211.1	241.1	0.51	0.32	0.22
251.4	281.4	7.58	7.12	6.92	251.4	281.4	19.28	19.53	21.62	251.4	281.4	0.52	0.31	0.23
291.7	321.7	7.53	7.09	6.88	291.7	321.7	16.67	21.16	20.82	291.7	321.7	0.53	0.32	0.21
331.9	361.9	7.49	7.09	6.89	331.9	361.9	18.47	19.43	24.90	331.9	361.9	0.53	0.32	0.20
372.2	402.2	7.49	7.09	6.88	372.2	402.2	17.61	19.85	20.43	372.2	402.2	0.52	0.30	0.20
412.4	442.4	7.41	7.02	6.82	412.4	442.4	19.15	17.48	22.49	412.4	442.4	0.53	0.33	0.22
452.7	482.7	7.46	7.08	6.87	452.7	482.7	17.77	19.74	22.64	452.7	482.7	0.51	0.31	0.23
493.0	523.0	7.47	7.06	6.85	493.0	523.0	17.63	23.53	27.35	493.0	523.0	0.51	0.32	0.24
533.2	563.2	7.45	7.06	6.82	533.2	563.2	16.46	19.39	21.02	533.2	563.2	0.47	0.31	0.23
573.5	603.5	7.49	7.10	6.87	573.5	603.5	17.22	18.06	21.97	573.5	603.5	0.51	0.32	0.23
613.7	643.7	7.48	7.11	6.89	613.7	643.7	17.03	18.56	17.02	613.7	643.7	0.52	0.32	0.23
654.0	684.0	7.48	7.10	6.89	654.0	684.0	17.98	19.30	17.69	654.0	684.0	0.67	0.42	0.30
694.3	724.3	7.49	7.09	6.87	694.3	724.3	18.55	22.73	17.96	694.3	724.3	0.68	0.43	0.32
734.5	764.5	7.51	7.09	6.87	734.5	764.5	18.03	22.33	20.61	734.5	764.5	0.78	0.48	0.35
774.8	804.8	7.54	7.13	6.90	774.8	804.8	16.86	23.50	27.97	774.8	804.8	0.79	0.55	0.38
815.0	845.0	7.58	7.16	6.93	815.0	845.0	13.18	19.60	18.12	815.0	845.0	0.91	0.65	0.47
855.3	885.3	7.69	7.24	6.97	855.3	885.3	11.45	17.11	22.48	855.3	885.3	0.92	0.65	0.50
895.6	925.6	7.75	7.28	6.99	895.6	925.6	9.71	16.20	20.41	895.6	925.6	0.94	0.70	0.53
935.8	965.8	7.92	7.43	7.11	935.8	965.8	8.25	12.49	18.66	935.8	965.8	0.99	0.75	0.60
976.1	1006.1	8.10	7.56	7.22	976.1	1006.1	6.93	10.38	15.85	976.1	1006.1	1.03	0.80	0.66
1016.3	1046.3	8.23	7.70	7.31	1016.3	1046.3	6.64	9.00	12.72	1016.3	1046.3	1.00	0.82	0.66
1056.6	1086.6	8.40	7.82	7.42	1056.6	1086.6	6.69	8.55	12.19	1056.6	1086.6	0.98	0.80	0.70
1096.9	1126.9	8.54	7.95	7.51	1096.9	1126.9	7.15	9.60	12.87	1096.9	1126.9	0.92	0.80	0.71
1137.1	1167.1	8.64	8.02	7.57	1137.1	1167.1	8.16	10.78	15.64	1137.1	1167.1	0.94	0.84	0.73
1177.4	1207.4	8.77	8.09	7.63	1177.4	1207.4	8.91	12.15	16.11	1177.4	1207.4	0.93	0.82	0.73
1217.6	1247.6	8.82	8.14	7.67	1217.6	1247.6	10.80	12.66	14.68	1217.6	1247.6	0.92	0.80	0.74
1257.9	1287.9	8.94	8.25	7.77	1257.9	1287.9	9.83	13.28	14.01	1257.9	1287.9	0.98	0.87	0.76
1298.2	1328.2	9.04	8.32	7.86	1298.2	1328.2	10.29	12.01	13.90	1298.2	1328.2	0.98	0.88	0.77
1338.4	1368.4	9.27	8.53	8.05	1338.4	1368.4	9.73	12.51	14.01	1338.4	1368.4	0.97	0.87	0.74
1378.7	1408.7	9.48	8.73	8.24	1378.7	1408.7	9.62	11.88	12.94	1378.7	1408.7	0.89	0.78	0.68
1418.9	1448.9	9.71	8.96	8.47	1418.9	1448.9	9.22	11.68	12.90	1418.9	1448.9	0.83	0.77	0.69
1459.2	1489.2	9.92	9.17	8.67	1459.2	1489.2	9.06	10.82	12.06	1459.2	1489.2	0.78	0.73	0.66
1499.5	1529.5	10.13	9.42	8.95	1499.5	1529.5	9.38	10.15	12.05	1499.5	1529.5	0.76	0.70	0.67
1539.7	1569.7	10.29	9.66	9.21	1539.7	1569.7	9.59	11.26	12.01	1539.7	1569.7	0.69	0.63	0.60
1580.0	1610.0	10.64	10.08	9.66	1580.0	1610.0	9.47	10.43	12.12	1580.0	1610.0	0.58	0.58	0.55
1600.1	1630.1	10.74	10.23	9.83	1600.1	1630.1	9.63	10.92	11.80	1600.1	1630.1	0.55	0.50	0.48



Frequency Mixer

ADE-12

Typical Performance Data

IF (OUT) (MHz)	LO (MHz)	CONVERSION LOSS VS. IF FREQUENCY @RF(IN)=500.6MHz (dB)	IF (OUT) (MHz)	LO (MHz)	CONVERSION LOSS VS. IF FREQUENCY @RF(IN)=50.1MHz (dB)	IF (OUT) (MHz)	LO (MHz)	CONVERSION LOSS VS. IF FREQUENCY @RF(IN)=1000.1MHz (dB)
		@LO (dBm)			@LO (dBm)			@LO (dBm)
		+7			+7			+7
400.5	100.1	7.02	10.0	60.1	7.27	950.0	50.1	7.73
390.5	110.1	7.02	30.0	80.1	7.29	930.0	70.1	7.74
380.5	120.1	6.99	50.0	100.1	7.26	910.0	90.1	7.69
370.5	130.1	6.93	70.0	120.1	7.32	890.0	110.1	7.62
360.5	140.1	6.91	90.0	140.1	7.32	870.0	130.1	7.55
350.5	150.1	6.92	110.0	160.1	7.33	850.0	150.1	7.55
340.5	160.1	6.90	130.0	180.1	7.33	830.0	170.1	7.52
330.5	170.1	6.89	150.0	200.1	7.36	810.0	190.1	7.47
320.5	180.1	6.88	170.0	220.1	7.35	790.0	210.1	7.45
310.5	190.1	6.88	190.0	240.1	7.38	770.0	230.1	7.41
300.5	200.1	6.88	210.0	260.1	7.39	750.0	250.1	7.37
290.5	210.1	6.87	230.0	280.1	7.40	730.0	270.1	7.44
280.5	220.1	6.86	250.0	300.1	7.43	710.0	290.1	7.44
270.5	230.1	6.85	270.0	320.1	7.41	690.0	310.1	7.38
260.5	240.1	6.84	290.0	340.1	7.46	670.0	330.1	7.35
250.5	250.1	6.44	310.0	360.1	7.46	650.0	350.1	7.37
240.5	260.1	6.82	330.0	380.1	7.47	630.0	370.1	7.36
230.5	270.1	6.81	350.0	400.1	7.49	610.0	390.1	7.37
220.5	280.1	6.82	370.0	420.1	7.52	590.0	410.1	7.34
210.5	290.1	6.90	390.0	440.1	7.55	570.0	430.1	7.35
200.5	300.1	6.90	410.0	460.1	7.52	550.0	450.1	7.35
190.5	310.1	6.91	430.0	480.1	7.67	530.0	470.1	7.34
180.5	320.1	6.90	450.0	500.1	7.58	510.0	490.1	7.32
170.5	330.1	6.91	470.0	520.1	7.56	490.0	510.1	7.35
160.5	340.1	6.90	510.0	560.1	7.59	450.0	550.1	7.36
150.5	350.1	6.91	530.0	580.1	7.66	430.0	570.1	7.43
140.5	360.1	6.93	570.0	620.1	7.72	390.0	610.1	7.33
130.5	370.1	6.95	590.0	640.1	7.71	370.0	630.1	7.34
120.5	380.1	6.99	630.0	680.1	7.75	330.0	670.1	7.38
110.5	390.1	7.00	650.0	700.1	7.74	310.0	690.1	7.37
100.5	400.1	6.96	690.0	740.1	7.70	270.0	730.1	7.36
90.5	410.1	6.97	710.0	760.1	7.78	250.0	750.1	7.36
80.5	420.1	6.95	750.0	800.1	7.71	210.0	790.1	7.37
70.5	430.1	7.01	770.0	820.1	7.68	190.0	810.1	7.38
60.5	440.1	7.00	810.0	860.1	7.66	150.0	850.1	7.44
50.5	450.1	7.00	830.0	880.1	7.65	130.0	870.1	7.43
40.5	460.1	7.02	870.0	920.1	7.57	90.0	910.1	7.47
30.5	470.1	7.04	890.0	940.1	7.62	70.0	930.1	7.45
20.5	480.1	7.09	930.0	980.1	7.60	30.0	970.1	7.55
10.5	490.1	7.05	950.0	1000.1	7.63	10.0	990.1	7.68

REV. X2
ADE-12
100817
Page 2 of 5



IF/RF MICROWAVE COMPONENTS • ISO 9001 ISO 14001 AS 9100 CERTIFIED • RoHS compliant
P.O. Box 350166, Brooklyn, New York 11235-0006 (718) 934-4500 Fax (718) 332-4661



The Design Engineers Search Engine finds the model you need, Instantly • For detailed performance specs & shopping online see



Typical Performance Data

LO (MHz)	LO-RF ISOLATION (dB)			LO-IF ISOLATION (dB)		
	@LO (dBm)			@LO (dBm)		
	+4	+7	+10	+4	+7	+10
50.1	56.42	55.89	56.18	59.50	57.49	56.61
90.4	50.80	51.03	50.98	57.18	55.04	53.32
130.6	47.64	47.78	48.27	54.39	52.63	51.71
170.9	45.32	45.77	45.73	52.43	51.00	50.16
211.1	43.60	43.84	44.25	51.23	50.30	49.28
251.4	42.25	42.58	42.72	49.98	49.04	48.37
291.7	41.04	41.45	41.53	49.00	48.34	47.08
331.9	40.09	40.30	40.80	47.33	46.76	46.29
372.2	39.27	39.66	39.59	45.81	45.38	44.69
412.4	38.56	38.75	39.09	44.38	44.44	44.16
452.7	37.97	38.34	38.34	42.44	42.75	42.99
493.0	37.39	37.69	37.98	40.99	41.52	41.77
533.2	36.83	37.12	37.36	39.58	40.05	40.53
573.5	36.33	36.85	36.77	38.44	39.27	39.52
613.7	36.04	36.15	36.61	37.21	38.06	39.26
654.0	35.75	36.16	36.01	36.40	36.97	37.85
694.3	35.63	35.77	36.12	35.88	36.39	37.00
734.5	35.51	35.81	35.70	35.22	35.53	35.95
774.8	35.57	35.69	35.80	34.85	35.42	35.46
815.0	35.70	35.64	35.67	34.07	35.28	35.76
855.3	35.80	35.95	35.60	33.05	34.89	35.80
895.6	35.96	35.83	35.98	32.16	34.00	35.60
935.8	36.15	36.27	35.84	31.33	33.11	34.71
976.1	36.16	36.25	36.25	30.65	32.39	34.16
1016.3	36.25	36.37	36.15	30.16	31.72	33.60
1056.6	36.12	36.41	36.27	29.60	31.16	32.76
1096.9	36.24	36.33	36.67	28.94	30.37	32.14
1137.1	36.25	36.60	36.52	28.28	29.50	30.72
1177.4	36.54	36.78	37.20	27.88	28.78	29.90
1217.6	36.97	37.43	37.36	27.56	28.10	28.92
1257.9	37.47	37.79	38.18	28.02	28.65	29.32
1298.2	37.88	38.46	38.54	28.69	29.34	30.09
1338.4	38.32	39.31	39.65	28.81	29.63	30.26
1378.7	38.42	39.59	40.51	28.55	29.27	30.23
1418.9	38.15	39.77	40.66	27.80	28.45	29.01
1459.2	37.25	38.69	40.12	27.13	27.68	28.36
1499.5	35.99	37.35	38.46	26.55	26.85	27.40
1539.7	34.80	35.98	37.40	26.17	26.49	26.99
1580.0	34.02	35.19	36.27	25.73	25.80	26.29
1600.1	33.58	34.83	35.73	25.72	25.83	26.09

RF (IN) (MHz)	LO (MHz)	RF-IF ISOLATION (dB)		
		@LO (dBm)		
		+4	+7	+10
50.1	80.1	42.26	41.38	43.45
90.4	120.4	37.48	38.26	37.93
130.6	160.6	34.44	35.14	35.84
170.9	200.9	32.16	32.85	33.60
211.1	241.1	30.68	31.39	31.98
251.4	281.4	29.30	30.12	30.67
291.7	321.7	28.21	29.11	29.68
331.9	361.9	27.55	28.33	28.84
372.2	402.2	26.78	27.66	28.38
412.4	442.4	26.30	27.29	28.01
452.7	482.7	25.85	26.88	27.71
493.0	523.0	25.61	26.73	27.53
533.2	563.2	25.57	26.61	27.48
573.5	603.5	25.71	26.77	27.59
613.7	643.7	26.10	27.27	28.33
654.0	684.0	26.51	27.83	29.13
694.3	724.3	26.72	28.37	29.73
734.5	764.5	26.80	28.57	29.94
774.8	804.8	26.23	27.58	28.35
815.0	845.0	25.66	26.55	26.85
855.3	885.3	24.92	25.44	25.58
895.6	925.6	24.18	24.43	24.39
935.8	965.8	23.55	23.62	23.52
976.1	1006.1	23.20	23.11	22.95
1016.3	1046.3	22.75	22.57	22.28
1056.6	1086.6	22.65	22.37	22.04
1096.9	1126.9	22.64	22.25	21.78
1137.1	1167.1	22.49	21.97	21.37
1177.4	1207.4	22.46	21.75	21.00
1217.6	1247.6	22.29	21.54	20.74
1257.9	1287.9	21.77	21.06	20.35
1298.2	1328.2	20.91	20.24	19.63
1338.4	1368.4	19.77	19.14	18.64
1378.7	1408.7	18.63	18.01	17.51
1418.9	1448.9	17.52	16.92	16.47
1459.2	1489.2	16.40	15.78	15.35
1499.5	1529.5	15.40	14.77	14.35
1539.7	1569.7	14.38	13.72	13.31
1580.0	1610.0	13.49	12.81	12.39
1600.1	1630.1	13.16	12.44	12.03

Typical Performance Data

RF (IN) (MHz)	LO (MHz)	RF VSWR (:1)		
		@LO (dBm)		
		+4	+7	+10
50.1	80.1	1.29	1.38	1.46
90.4	120.4	1.20	1.29	1.36
130.6	160.6	1.24	1.34	1.41
170.9	200.9	1.21	1.31	1.37
211.1	241.1	1.28	1.38	1.45
251.4	281.4	1.28	1.38	1.44
291.7	321.7	1.29	1.39	1.45
331.9	361.9	1.32	1.40	1.47
372.2	402.2	1.33	1.42	1.48
412.4	442.4	1.35	1.43	1.50
452.7	482.7	1.35	1.43	1.50
493.0	523.0	1.37	1.46	1.51
533.2	563.2	1.40	1.48	1.54
573.5	603.5	1.43	1.51	1.57
613.7	643.7	1.47	1.55	1.61
654.0	684.0	1.54	1.62	1.69
694.3	724.3	1.56	1.64	1.70
734.5	764.5	1.64	1.72	1.78
774.8	804.8	1.63	1.71	1.76
815.0	845.0	1.67	1.74	1.80
855.3	885.3	1.67	1.73	1.79
895.6	925.6	1.69	1.75	1.80
935.8	965.8	1.70	1.74	1.79
976.1	1006.1	1.74	1.77	1.81
1016.3	1046.3	1.84	1.85	1.89
1056.6	1086.6	1.92	1.93	1.95
1096.9	1126.9	2.13	2.12	2.13
1137.1	1167.1	2.31	2.29	2.29
1177.4	1207.4	2.55	2.52	2.50
1217.6	1247.6	2.77	2.71	2.68
1257.9	1287.9	2.98	2.91	2.86
1298.2	1328.2	3.13	3.03	2.98
1338.4	1368.4	3.42	3.31	3.24
1378.7	1408.7	3.47	3.34	3.27
1418.9	1448.9	3.78	3.65	3.54
1459.2	1489.2	3.91	3.78	3.67
1499.5	1529.5	4.26	4.10	3.97
1539.7	1569.7	4.34	4.19	4.05
1580.0	1610.0	4.54	4.39	4.25
1600.1	1630.1	4.55	4.40	4.27

LO (MHz)	LO VSWR (:1)		
	@LO (dBm)		
	+4	+7	+10
50.1	1.75	2.51	3.50
90.4	1.74	2.48	3.41
130.6	1.73	2.47	3.40
170.9	1.72	2.44	3.38
211.1	1.72	2.42	3.28
251.4	1.75	2.47	3.38
291.7	1.74	2.44	3.31
331.9	1.76	2.49	3.38
372.2	1.81	2.55	3.48
412.4	1.82	2.55	3.42
452.7	1.85	2.59	3.51
493.0	1.85	2.53	3.38
533.2	1.87	2.58	3.44
573.5	1.90	2.58	3.41
613.7	1.95	2.65	3.50
654.0	2.01	2.70	3.56
694.3	2.03	2.71	3.52
734.5	2.08	2.78	3.61
774.8	2.10	2.75	3.52
815.0	2.13	2.77	3.54
855.3	2.19	2.82	3.56
895.6	2.22	2.84	3.56
935.8	2.30	2.94	3.69
976.1	2.34	2.96	3.66
1016.3	2.39	3.02	3.76
1056.6	2.40	3.00	3.71
1096.9	2.38	2.97	3.67
1137.1	2.38	2.94	3.60
1177.4	2.39	2.92	3.56
1217.6	2.39	2.89	3.55
1257.9	2.44	2.92	3.54
1298.2	2.44	2.92	3.54
1338.4	2.51	2.96	3.57
1378.7	2.54	2.97	3.58
1418.9	2.58	2.98	3.55
1459.2	2.63	2.99	3.54
1499.5	2.65	2.97	3.50
1539.7	2.72	3.01	3.51
1580.0	2.79	3.06	3.54
1600.1	2.82	3.07	3.54

IF (OUT) (MHz)	IF VSWR @LO=1000.1MHz (:1)		
	@LO (dBm)		
	+4	+7	+10
10.0	2.30	1.90	1.55
30.2	2.16	1.88	1.63
50.4	2.05	1.73	1.51
70.6	2.05	1.73	1.53
90.8	2.10	1.77	1.56
111.0	2.11	1.78	1.57
131.2	2.10	1.78	1.57
151.4	2.07	1.75	1.55
171.6	2.07	1.76	1.56
191.8	2.08	1.78	1.58
212.0	2.08	1.77	1.57
232.2	2.06	1.77	1.57
252.4	2.05	1.75	1.57
272.7	2.04	1.75	1.57
292.9	2.04	1.77	1.59
313.1	2.04	1.76	1.59
333.3	2.01	1.74	1.57
353.5	1.99	1.72	1.57
373.7	1.99	1.73	1.58
393.9	2.00	1.74	1.60
434.3	1.97	1.73	1.60
454.5	1.96	1.73	1.60
494.9	1.97	1.75	1.63
515.1	1.97	1.75	1.64
555.5	1.96	1.75	1.66
575.7	1.98	1.78	1.69
616.1	1.96	1.76	1.69
636.3	1.97	1.78	1.70
676.7	1.98	1.80	1.73
696.9	2.00	1.81	1.74
737.3	1.99	1.80	1.74
757.6	2.00	1.81	1.75
798.0	2.00	1.81	1.75
818.2	2.00	1.81	1.76
858.6	2.01	1.83	1.77
878.8	2.02	1.82	1.76
919.2	2.01	1.82	1.76
939.4	2.02	1.83	1.76
979.8	2.05	1.85	1.79
1000.0	1.85	1.89	2.10

Harmonics Tables

RF HARMONICS ORDER

	(-dBm)	(-dBc)										
0	-	-	17	16	16	35	15	30	21	38	37	51
1	-	19	0	39	12	50	20	37	40	44	47	42
2	109	68	58	71	58	68	57	67	56	69	57	67
3	113	68	71	69	67	77	63	74	69	91	72	85
4	120	100	97	106	90	78	95	97	95	97	96	102
5	119	98	105	104	96	91	86	92	98	100	99	107
6	128	105	109	115	103	94	96	91	96	103	105	111
7	112	117	104	101	100	95	97	91	91	96	101	113
8	116	99	101	108	103	110	105	100	90	88	99	114
9	111	107	100	106	110	101	122	99	93	94	89	108
10	120	104	101	108	111	103	107	111	109	103	97	94
	RF CAL	0	1	2	3	4	5	6	7	8	9	10

LO HARMONICS ORDER

Test conditions: RF IN: 500.1 MHz; -14.00 dBm.
 LO IN: 530.01 MHz; +7.00 dBm
 IF OUT: 29.91 MHz; -20.92 dBm

RF HARMONICS ORDER

	(-dBm)	(-dBc)										
0	-	-	26	26	27	45	27	42	34	53	53	77
1	-	20	0	38	12	49	21	40	40	49	52	48
2	94	62	49	78	49	63	50	65	49	59	50	62
3	110	48	51	50	67	62	47	59	56	61	59	63
4	109	78	76	72	72	71	75	70	65	72	68	81
5	142	80	70	89	61	79	58	79	57	70	59	76
6	112	104	92	89	86	91	84	87	81	89	81	87
7	113	91	88	89	79	95	81	89	82	87	98	89
8	112	107	97	106	100	103	117	104	98	101	100	104
9	109	107	115	104	102	109	96	111	97	103	89	102
10	113	116	110	127	119	115	108	110	112	105	102	105
	RF CAL	0	1	2	3	4	5	6	7	8	9	10

LO HARMONICS ORDER

Test conditions: RF IN: 500.1 MHz; -4.00 dBm.
 LO IN: 530.01 MHz; +7.00 dBm
 IF OUT: 29.91 MHz; -10.85 dBm

- Notes: 1. All Harmonics are in (dBc) relative to IF OUTPUT.
 2. + entry denotes harmonics are in (dBc) above IF OUTPUT.
 3. RF Cal represent the Harmonics level of the RF input signal to the mixer.

REV. X2
 ADE-12
 100817

Page 5 of 5



IF/RF MICROWAVE COMPONENTS • ISO 9001 ISO 14001 AS 9100 CERTIFIED • RoHS compliant
 P.O. Box 350166, Brooklyn, New York 11235-0006 (718) 934-4500 Fax (718) 332-4661



The Design Engineers Search Engine finds the model you need, Instantly • For detailed performance specs & shopping online see [minicircuits.com](http://www.minicircuits.com)

Typical Performance Curves

Conversion Loss @ IF=30MHz

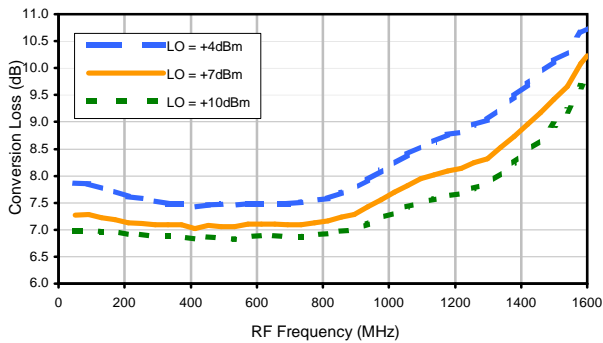

Conversion Loss vs. IF @ RF=500.6MHz

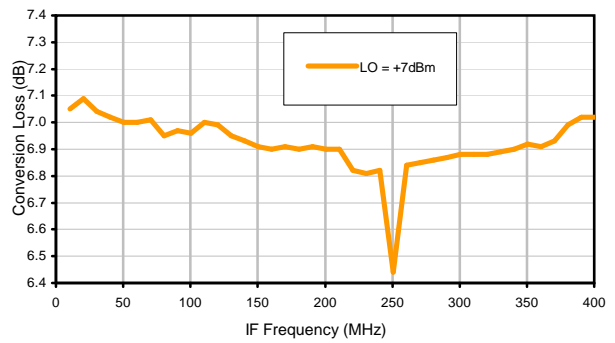

Conversion Loss vs. IF @ RF=50.1MHz

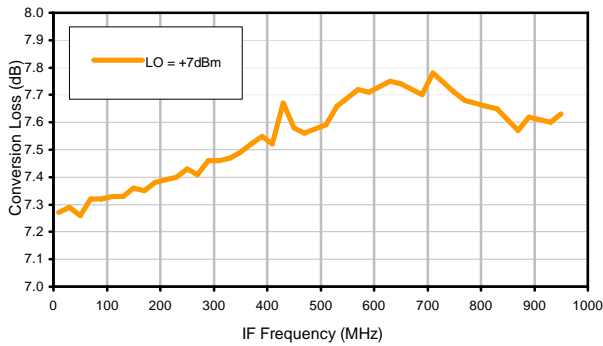

Conversion Loss vs. IF @ RF=1000.1MHz

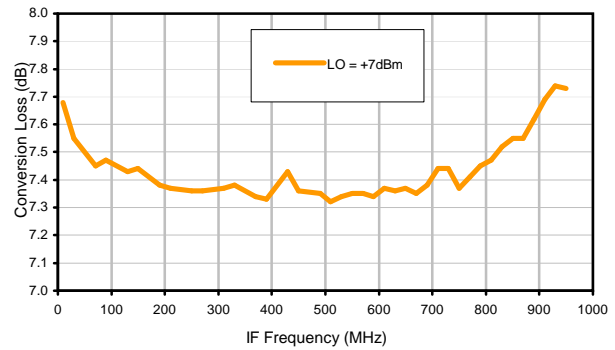

IP3 Input

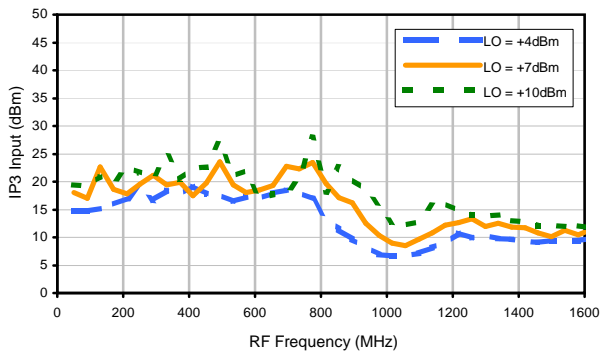

Compression @ RF IN=+1dBm

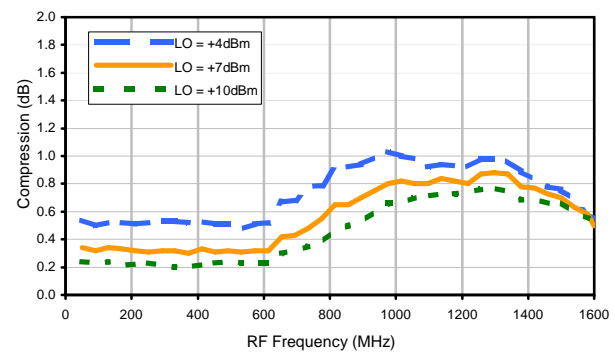

Typical Performance Curves

LO-RF Isolation

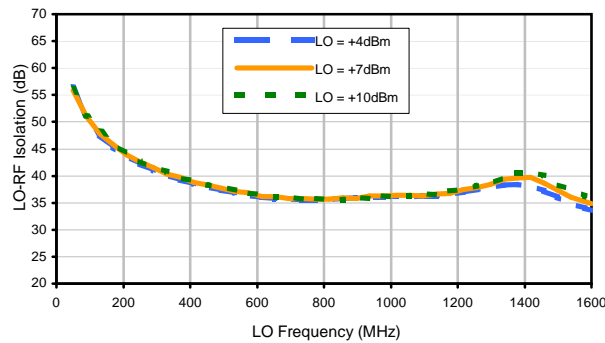

LO-IF Isolation

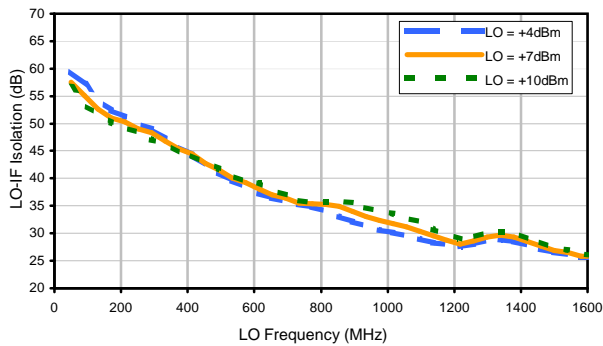

RF-IF Isolation

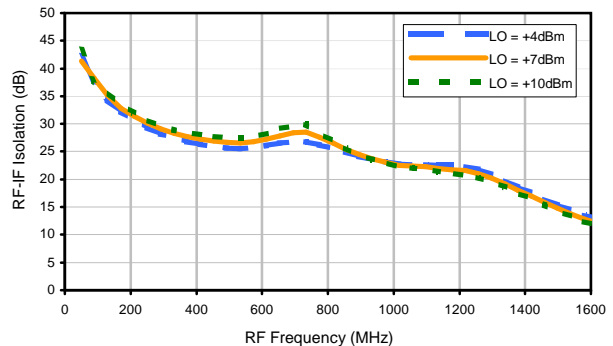

RF VSWR

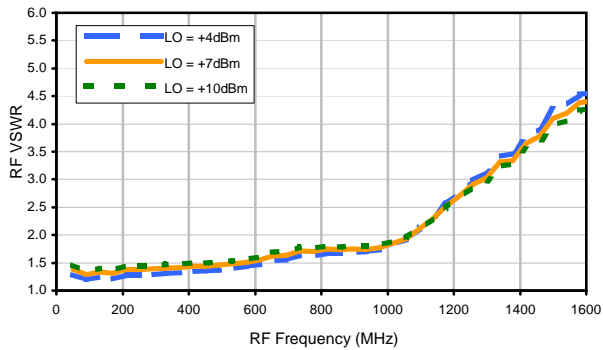

LO VSWR

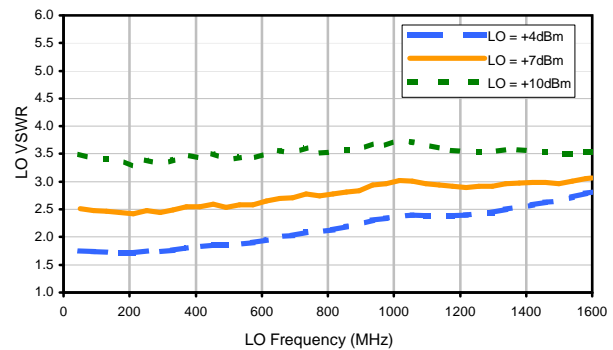

IF VSWR

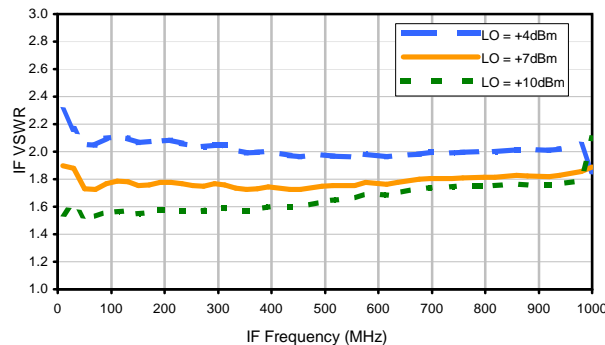

Harmonics Tables

RF HARMONICS ORDER

	(-dBm)	(-dBc)										
0	-	-	17	16	16	35	15	30	21	38	37	51
1	-	19	0	39	12	50	20	37	40	44	47	42
2	109	68	58	71	58	68	57	67	56	69	57	67
3	113	68	71	69	67	77	63	74	69	91	72	85
4	120	100	97	106	90	78	95	97	95	97	96	102
5	119	98	105	104	96	91	86	92	98	100	99	107
6	128	105	109	115	103	94	96	91	96	103	105	111
7	112	117	104	101	100	95	97	91	91	96	101	113
8	116	99	101	108	103	110	105	100	90	88	99	114
9	111	107	100	106	110	101	122	99	93	94	89	108
10	120	104	101	108	111	103	107	111	109	103	97	94
	RF CAL	0	1	2	3	4	5	6	7	8	9	10

LO HARMONICS ORDER

Test conditions: RF IN: 500.1 MHz; -14.00 dBm.
 LO IN: 530.01 MHz; +7.00 dBm
 IF OUT: 29.91 MHz; -20.92 dBm

RF HARMONICS ORDER

	(-dBm)	(-dBc)										
0	-	-	26	26	27	45	27	42	34	53	53	77
1	-	20	0	38	12	49	21	40	40	49	52	48
2	94	62	49	78	49	63	50	65	49	59	50	62
3	110	48	51	50	67	62	47	59	56	61	59	63
4	109	78	76	72	72	71	75	70	65	72	68	81
5	142	80	70	89	61	79	58	79	57	70	59	76
6	112	104	92	89	86	91	84	87	81	89	81	87
7	113	91	88	89	79	95	81	89	82	87	98	89
8	112	107	97	106	100	103	117	104	98	101	100	104
9	109	107	115	104	102	109	96	111	97	103	89	102
10	113	116	110	127	119	115	108	110	112	105	102	105
	RF CAL	0	1	2	3	4	5	6	7	8	9	10

LO HARMONICS ORDER

Test conditions: RF IN: 500.1 MHz; -4.00 dBm.
 LO IN: 530.01 MHz; +7.00 dBm
 IF OUT: 29.91 MHz; -10.85 dBm

- Notes: 1. All Harmonics are in (dBc) relative to IF OUTPUT.
 2. + entry denotes harmonics are in (dBc) above IF OUTPUT.
 3. RF Cal represent the Harmonics level of the RF input signal to the mixer.

REV. X2
 ADE-12
 100817

Page 3 of 3



IF/RF MICROWAVE COMPONENTS • ISO 9001 ISO 14001 AS 9100 CERTIFIED • RoHS compliant
 P.O. Box 350166, Brooklyn, New York 11235-0006 (718) 934-4500 Fax (718) 332-4661



The Design Engineers Search Engine finds the model you need, Instantly • For detailed performance specs & shopping online see



Case Style

CD

CD541
CD542
CD636
CD637

Outline Dimensions



PCB Land Pattern



Suggested Layout,
Tolerance to be within $\pm .002$

CASE#	A	B	C	D	E	F	G	H	J	K	L	WT, GRAM
CD541					.082 (2.08)							.15
CD542	.272 (6.91)	.310 (7.87)	.220 (5.58)	.100 (2.54)	.112 (2.84)	.055 (1.40)	.100 (2.54)	.030 (0.76)	.026 (0.66)	.065 (1.65)	.300 (7.62)	.20
CD636					.162 (4.11)							.25
CD637					.206 (5.23)							.40

Dimensions are in inches (mm). Tolerances: 2 Pl. $\pm .01$; 3 Pl. $\pm .005$

Notes:

- Case material: Plastic.
- Termination finish:
 - For RoHS Case Styles: Tin plate over Nickel plate. All models, (+) suffix.
 - For RoHS-5 Case Styles: Tin-Lead plate. All models, no (+) suffix.

Mini-Circuits

INTERNET <http://www.minicircuits.com>

P.O. Box 350166, Brooklyn, New York 11235-0003 (718) 934-4500 Fax (718) 332-4661

Distribution Centers NORTH AMERICA 800-654-7949 • 417-335-5935 • Fax 417-335-5945 • EUROPE 44-1252-832600 • Fax 44-1252-837010

Mini-Circuits ISO 9001 & ISO 14001 Certified

Tape & Reel Packaging TR-F34



Tape Width, mm	Device Cavity Pitch, mm	Reel Size, inches	Devices per Reel see note	
16	12	7	Small quantity standard (see note)	20
				50
			Standard	100
				200
		13	Standard	500
				1000

Note: Availability of small reel quantity varies by model.
Refer to pricing and availability on individual model dashboard.

Mini-Circuits carrier tape materials provide protection from ESD (Electro-Static Discharge) during handling and transportation. Tapes are static dissipative and comply with industry standards EIA-481/EIA-541.

Go to: www.minicircuits.com/pages/pdfs/tape.pdf



INTERNET <http://www.minicircuits.com>

P.O. Box 350166, Brooklyn, New York 11235-0003 (718) 934-4500 Fax (718) 332-4661

Distribution Centers NORTH AMERICA 800-654-7949 • 417-335-5935 • Fax 417-335-5945 • EUROPE 44-1252-832600 • Fax 44-1252-837010

Mini-Circuits ISO 9001 & ISO 14001 Certified

THIRD ANGLE PROJECTION





REVISIONS

REV	ECN No.	DESCRIPTION	DATE	DR	AUTH
OR	M82272	NEW RELEASE	08/05/02	MMG	DJ
A	M102713	ADDED NOTE 2 & "...WITH SMOBC"	01/17/06	MMG	IL

**SUGGESTED MOUNTING CONFIGURATION
FOR CD541/542/636/637 CASE STYLES,
"jv", "ju", "jw" PIN CONNECTIONS**

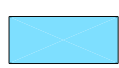

- NOTES:** 1. TRACE WIDTH IS SHOWN FOR ROGERS R04350B WITH DIELECTRIC THICKNESS .030" ± .002"; COPPER: 1/2 OZ. EACH SIDE. FOR OTHER MATERIALS TRACE WIDTH MAY NEED TO BE MODIFIED.
2. BOTTOM SIDE OF THE PCB IS CONTINUOUS GROUND PLANE.

-  DENOTES PCB COPPER LAYOUT WITH SMOBC (SOLDER MASK OVER BARE COPPER)
 DENOTES COPPER LAND PATTERN FREE OF SOLDER MASK

UNLESS OTHERWISE SPECIFIED

DIMENSIONS ARE IN INCHES
TOLERANCES ON:
2 PL DECIMALS ±
3 PL DECIMALS ± .005
ANGLES ±
FRACTIONS ±

	INITIALS	DATE
DRAWN	MMG	07/17/02
CHECKED	WL	08/02/02
APPROVED	DJ	08/05/02



Mini-Circuits®

13 Neptune Avenue
Brooklyn NY 11235

PL, jv/ju/jw, CD541/542/636/637, ADE, TB-02

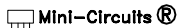
 Mini-Circuits®
THIS DOCUMENT AND ITS CONTENTS ARE THE PROPERTY OF MINI-CIRCUITS. EXCEPT FOR USE EXPRESSLY GRANTED, IN WRITING, TO ITS VENDORS, VENDEE AND THE UNITED STATES GOVERNMENT, MINI-CIRCUITS RESERVES ALL PROPRIETARY DESIGN, USE, MANUFACTURING AND REPRODUCTION RIGHTS THERETO. THESE CONTENTS SHALL NOT BE USED, DUPLICATED OR DISCLOSED TO ANY OUTSIDE PARTY, IN WHOLE OR IN PART, WITHOUT WRITTEN PERMISSION OF MINI-CIRCUITS.

ASHEETA1.DWG REV:A DATE:01/12/95

SIZE	CODE IDENT	DRAWING NO:	REV:
A	15542	98-PL-051	A
FILE:	98PL051	SCALE: 8:1	SHEET: 1 OF 1

Evaluation Board and Circuit

For Pin Connections refer to Data Sheet of the DUT

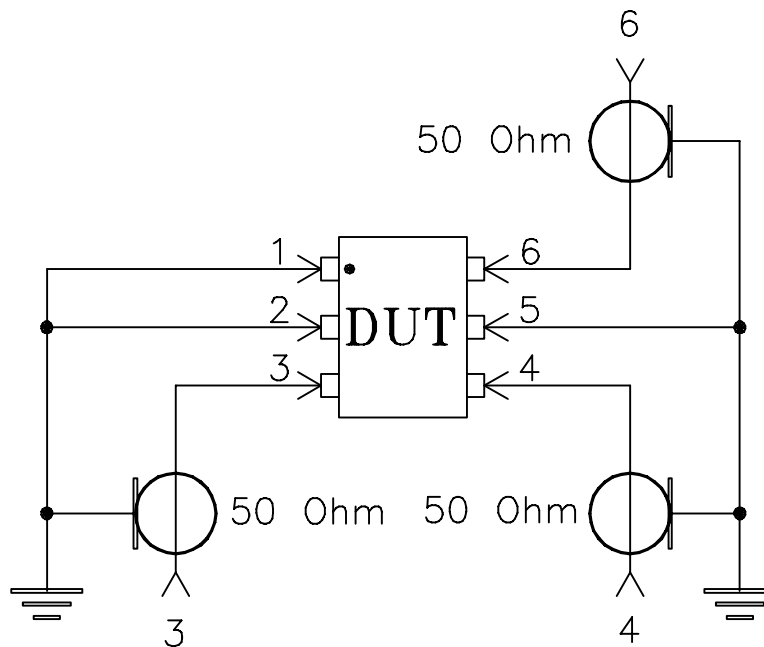

Schematic Diagram

Notes:

1. SMA Female connectors.
2. PCB Material: Rogers R04350 or equivalent,
Dielectric Constant=3.5, Thickness=.030 inch.

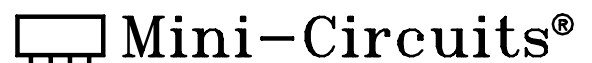

All Mini-Circuits products are manufactured under exacting quality assurance and control standards, and are capable of meeting published specifications after being subjected to any or all of the following physical and environmental test.

Specification	Test/Inspection Condition	Reference/Spec
Operating Temperature	-40° to 85°C Ambient Environment	Individual Model Data Sheet
Storage Temperature	-55° to 100° C Ambient Environment	Individual Model Data Sheet
Humidity	90 to 95% RH, 240 hours, 50°C	MIL-STD-202, Method 103, Condition A, Except 50°C and end-point electrical test done within 12 hours
Thermal Shock	-55° to 100°C, 100 cycles	MIL-STD-202, Method 107, Condition A-3, except +100°C
Solder Reflow Heat	Sn-Pb Eutetic Process: 225°C peak Pb-Free Process 245° - 250°C peak	J-STD-020, Table 4-1, 4-2 and 5-2, Figure 5-1
Solderability	10X Magnification	J-STD-002, 95% Coverage
Vibration (High Frequency)	20g peak, 10-2000 Hz, 12 times in each of three perpendicular directions (total 36)	MIL-STD-202, Method 204, Condition D
Mechanical Shock	50g, 11 ms, 1/2-sine, 18 shocks: 3 each direction, each of 3 axes	MIL-STD-202, Method 213, Condition A
Marking Resistance to Solvents	Isopropyl alcohol + mineral spirits at 25°C; terpene defluxer at 25°C; distilled water + proylene glycol monomethyl ether + monoethanolamine at 63°C to 70°C	MIL-STD-202, Method 215