

# Frequency Mixer

## ADE-92MH+

Level 13 (LO Power +13 dBm) 400 to 900 MHz

### The Big Deal

- Excellent IP3: +26dBm with reduced LO power (+13dBm)
- High LO-RF Isolation across the entire band
- Low cost, miniature size



CASE STYLE: CD636

### Product Overview

The ADE-92MH+ is passive double balanced mixer featuring a FET quad in a ring configuration providing high dynamic range performance in a small, low cost, RoHS-compliant package. The ADE-92MH+ provides RF/LO response from 400 to 900 MHz and IF response from DC to 150 MHz. It is especially useful in systems where cost and performance are critical, such as GSM cellular system applications. This mixer is ideal for upconverter and downconverter applications and does not require external matching components or DC power.

### Key Features

Feature	Advantages
High IP3, +26 dBm typ. with reduced LO power requirement.	Allows for improved dynamic range, a critical factor in receiver applications.
Low conversion loss, 7 dB typ.	Enables lower NF front ends, which can improve system sensitivity.
High LO to RF isolation, 40 dB typ.	Reduced levels of unwanted responses that can interfere with system performance.
Broadband matching	The IF port VSWR is less than 1.6 to 1 over the specified frequency range, which simplifies impedance matching with adjoining components.
Insensitive to LO power level variations	Allows the use of an LO amplifier with less stringent gain flatness, enabling the use of lower cost amplifiers.
Small package 0.310" x 0.220" x 0.162"	Enables high density packaging.

#### Notes

- A. Performance and quality attributes and conditions not expressly stated in this specification document are intended to be excluded and do not form a part of this specification document.
- B. Electrical specifications and performance data contained in this specification document are based on Mini-Circuit's applicable established test performance criteria and measurement instructions.
- C. The parts covered by this specification document are subject to Mini-Circuits standard limited warranty and terms and conditions (collectively, "Standard Terms"); Purchasers of this part are entitled to the rights and benefits contained therein. For a full statement of the Standard Terms and the exclusive rights and remedies thereunder, please visit Mini-Circuits' website at [www.minicircuits.com/MCLStore/terms.jsp](http://www.minicircuits.com/MCLStore/terms.jsp)



# High IP3 Frequency Mixer

## ADE-92MH+

Level 13 (LO Power +13 dBm) 400 to 900 MHz



CASE STYLE: CD636

### Maximum Ratings

Operating Temperature	-40°C to 85°C
Storage Temperature	-55°C to 100°C
RF Power	100 mW
IF Current	40 mA

Permanent damage may occur if any of these limits are exceeded.

### Pin Connections

LO	6
RF	3
IF	2
GROUND	1,4,5

### Outline Drawing

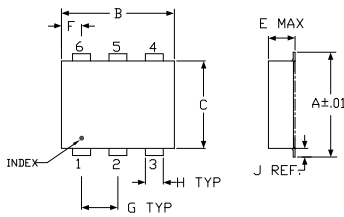

### PCB Land Pattern

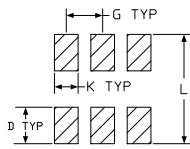

Suggested Layout  
Tolerance to be within ±0.02

### Outline Dimensions (inch mm)

A	B	C	D	E	F	G
.272	.310	.220	.100	.162	.055	.100
6.91	7.87	5.58	2.54	4.11	1.40	2.54
H	J	K	L	wt		
.030	.026	.065	.300	grams		
0.76	0.66	1.65	7.62	.25		

### Demo Board MCL P/N: TB-03 Suggested PCB Layout (PL-052)

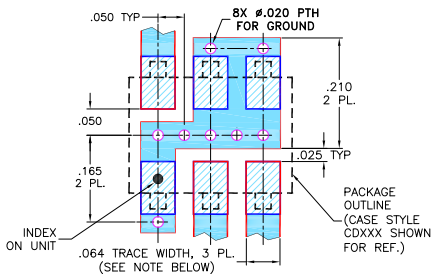

- NOTES: 1. TRACE WIDTH IS SHOWN FOR ROGERS RO4350B WITH DIELECTRIC THICKNESS .030"±.002"; COPPER: 1/2 OZ. EACH SIDE. FOR OTHER MATERIALS TRACE WIDTH MAY NEED TO BE MODIFIED.  
2. BOTTOM SIDE OF THE PCB IS CONTINUOUS GROUND PLANE.

- DENOTES PCB COPPER LAYOUT WITH SMOBC (SOLDER MASK OVER BARE COPPER)
- DENOTES COPPER LAND PATTERN FREE OF SOLDER MASK

A. Performance and quality attributes and conditions not expressly stated in this specification document are intended to be excluded and do not form a part of this specification document.

B. Electrical specifications and performance data contained in this specification document are based on Mini-Circuits' applicable established test performance criteria and measurement instructions.

C. The parts covered by this specification document are subject to Mini-Circuits standard limited warranty and terms and conditions (collectively, "Standard Terms"); Purchasers of this part are entitled to the rights and benefits contained therein. For a full statement of the Standard Terms and the exclusive rights and remedies thereunder, please visit Mini-Circuits' website at [www.minicircuits.com/MCLStore/terms.jsp](http://www.minicircuits.com/MCLStore/terms.jsp)

### Features

- high IP3, +26 dBm typ.
- good L-R isolation, 40 dB typ.
- good L-I isolation, 26 dB typ.
- aqueous washable
- patent pending

### Applications

- cellular
- GSM
- ISM

### Electrical Specifications

FREQUENCY (MHz)	CONVERSION LOSS (dB)	LO-RF ISOLATION (dB)		LO-IF ISOLATION (dB)		IP3 at center band (dBm)			
		Typ.	Min.	Typ.	Min.				
400-900	DC-150	6.8	0.1	9.5	40	31	26	26	26

1 dB COMP.: +17 dBm typ.

\* Conversion Loss increases up to 10dB @ IF Frequency 120-150MHz.

### Typical Performance Data

Frequency (MHz)	Conversion Loss (dB)		Isolation L-R (dB)		Isolation L-I (dB)		VSWR RF PORT (:1)		VSWR LO PORT (:1)		IP3 (dBm)
	RF	LO	LO +13dBm	LO +13dBm	LO +13dBm	LO +13dBm	LO +13dBm	LO +13dBm	LO +13dBm	LO +13dBm	
400.10	470.10	6.00	41.12	29.53	2.04	23.05	21.44				
420.10	490.10	5.92	41.61	29.73	2.06	21.62	21.45				
460.10	530.10	5.94	42.40	29.67	2.18	18.66	22.35				
500.10	570.10	6.01	42.95	28.80	2.30	14.98	24.42				
520.10	590.10	5.99	42.91	27.98	2.32	13.08	25.06				
540.10	610.10	6.05	42.41	27.10	2.36	11.16	25.17				
580.10	650.10	6.30	41.11	25.72	2.58	8.27	27.7				
600.10	670.10	6.39	40.28	25.13	2.65	6.95	31.09				
620.10	690.10	6.50	39.48	24.62	2.74	6.00	35.77				
640.10	710.10	6.62	38.60	24.26	2.82	5.18	35.96				
680.10	750.10	6.79	37.21	23.98	2.93	4.00	36.11				
700.10	770.10	6.92	37.10	23.91	3.01	3.63	31.27				
740.10	810.10	7.14	37.75	23.99	3.16	3.20	26.18				
760.10	830.10	7.27	38.76	24.25	3.19	3.13	26.81				
780.10	850.10	7.29	39.88	24.64	3.16	3.11	29.23				
800.10	870.10	7.27	40.11	25.10	3.13	3.16	31.98				
840.10	910.10	7.42	39.42	26.01	3.20	3.38	33.03				
860.10	930.10	7.54	39.18	26.21	3.28	3.52	34.97				
880.10	950.10	7.60	39.00	26.17	3.33	3.67	35.44				
900.10	970.10	7.74	38.91	26.15	3.43	3.85	33.43				

### Electrical Schematic

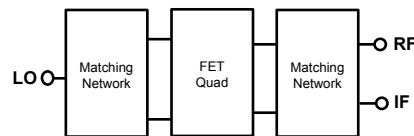

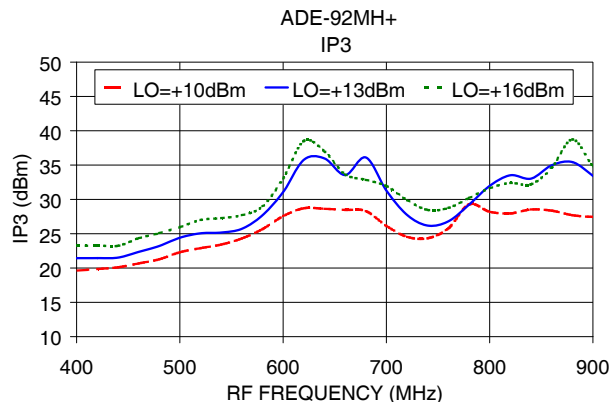
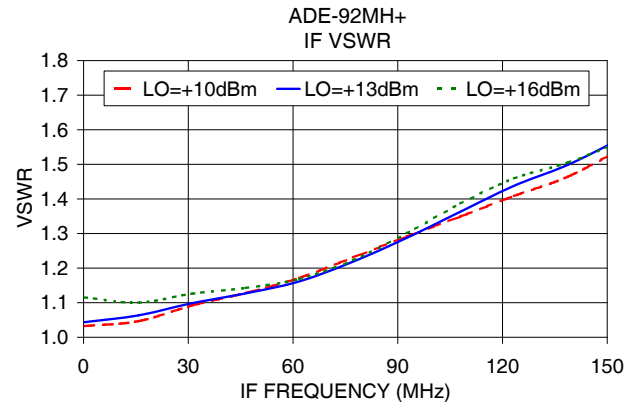
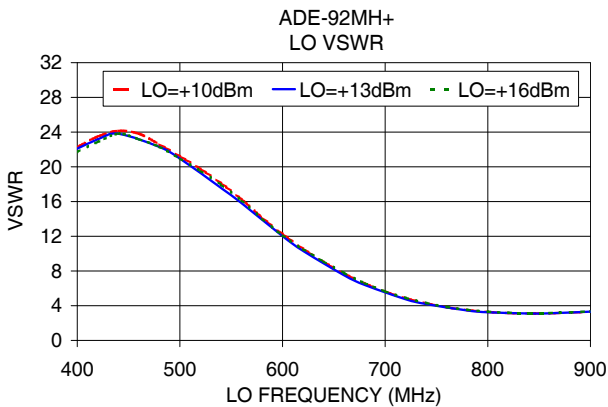
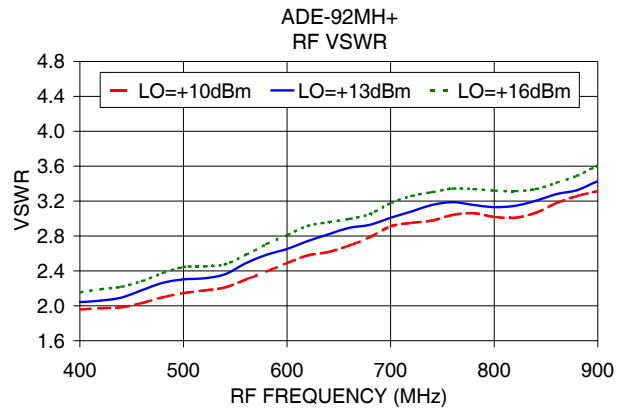
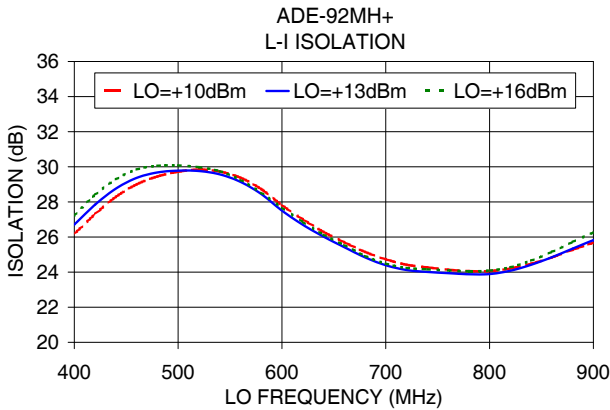
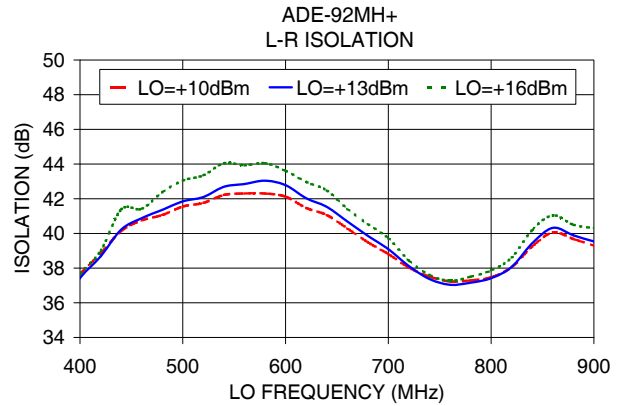
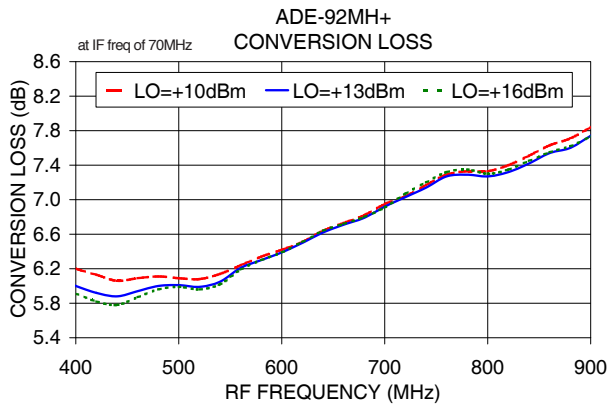

**Notes**

- A. Performance and quality attributes and conditions not expressly stated in this specification document are intended to be excluded and do not form a part of this specification document.
- B. Electrical specifications and performance data contained in this specification document are based on Mini-Circuits' applicable established test performance criteria and measurement instructions.
- C. The parts covered by this specification document are subject to Mini-Circuits standard limited warranty and terms and conditions (collectively, "Standard Terms"); Purchasers of this part are entitled to the rights and benefits contained therein. For a full statement of the Standard Terms and the exclusive rights and remedies thereunder, please visit Mini-Circuits' website at [www.minicircuits.com/MCLStore/terms.jsp](http://www.minicircuits.com/MCLStore/terms.jsp)



# Frequency Mixer

# ADE-92MH+

## Typical Performance Data

RF (MHz)	LO (MHz)	CONVERSION LOSS (dB)			LO (MHz)	LO-RF ISOLATION (dB)			LO-IF ISOLATION (dB)		
		@LO (dBm)				@LO (dBm)			@LO (dBm)		
		+10	+13	+16		+10	+13	+16	+10	+13	+16
200.1	270.1	11.36	10.96	10.69	200.1	25.85	25.63	25.56	17.12	17.30	17.49
220.1	290.1	10.25	9.91	9.69	220.1	24.94	24.86	24.81	16.51	16.71	16.89
240.1	310.1	9.10	8.72	8.49	240.1	24.47	24.38	24.21	16.75	16.98	17.07
260.1	330.1	8.11	7.68	7.36	260.1	24.70	24.59	24.49	17.55	17.80	17.99
280.1	350.1	7.53	7.12	6.87	280.1	25.57	25.47	25.39	18.65	18.93	19.17
300.1	370.1	7.10	6.75	6.52	300.1	26.97	26.91	26.90	19.88	20.17	20.42
320.1	390.1	6.82	6.54	6.34	320.1	28.84	28.79	28.80	21.35	21.71	22.00
340.1	410.1	6.57	6.32	6.15	340.1	31.60	31.67	32.18	22.88	23.31	23.66
360.1	430.1	6.40	6.18	6.04	360.1	33.92	33.91	34.06	24.12	24.58	24.95
380.1	450.1	6.29	6.09	6.00	380.1	35.83	35.69	35.78	25.20	25.72	26.19
400.1	470.1	6.20	6.00	5.91	400.1	37.63	37.43	37.65	26.19	26.72	27.24
420.1	490.1	6.13	5.92	5.82	420.1	38.84	38.68	38.99	27.31	27.85	28.41
440.1	510.1	6.06	5.88	5.78	440.1	40.14	40.22	41.38	28.29	28.76	29.29
460.1	530.1	6.09	5.94	5.87	460.1	40.75	40.88	41.42	29.00	29.37	29.85
480.1	550.1	6.11	6.00	5.96	480.1	41.06	41.36	42.38	29.45	29.68	30.06
500.1	570.1	6.09	6.01	5.99	500.1	41.55	41.85	43.05	29.72	29.78	30.08
520.1	590.1	6.08	5.99	5.96	520.1	41.76	42.10	43.35	29.84	29.76	29.98
540.1	610.1	6.14	6.05	6.02	540.1	42.22	42.69	44.05	29.73	29.57	29.75
560.1	630.1	6.24	6.21	6.19	560.1	42.30	42.85	43.93	29.38	29.14	29.25
580.1	650.1	6.34	6.30	6.30	580.1	42.30	43.04	44.05	28.73	28.45	28.52
600.1	670.1	6.42	6.39	6.39	600.1	42.12	42.78	43.61	27.81	27.50	27.67
620.1	690.1	6.51	6.50	6.51	620.1	41.47	42.03	42.97	27.01	26.70	26.86
640.1	710.1	6.64	6.62	6.64	640.1	41.06	41.53	42.48	26.29	26.02	26.13
660.1	730.1	6.73	6.71	6.72	660.1	40.29	40.69	41.42	25.70	25.42	25.54
680.1	750.1	6.82	6.79	6.80	680.1	39.49	39.86	40.54	25.15	24.84	24.92
700.1	770.1	6.95	6.92	6.91	700.1	38.81	39.09	39.72	24.73	24.39	24.48
720.1	790.1	7.04	7.03	7.07	720.1	38.03	38.11	38.43	24.42	24.12	24.24
740.1	810.1	7.17	7.14	7.20	740.1	37.51	37.37	37.60	24.27	24.01	24.16
760.1	830.1	7.29	7.27	7.32	760.1	37.23	37.04	37.27	24.14	23.94	24.10
780.1	850.1	7.33	7.29	7.35	780.1	37.29	37.16	37.50	24.06	23.88	24.05
800.1	870.1	7.33	7.27	7.30	800.1	37.47	37.42	37.87	24.06	23.89	24.09
820.1	890.1	7.40	7.32	7.35	820.1	38.06	38.07	38.61	24.21	24.08	24.28
840.1	910.1	7.51	7.42	7.45	840.1	39.25	39.44	40.21	24.48	24.42	24.66
860.1	930.1	7.63	7.54	7.55	860.1	40.06	40.32	41.04	24.84	24.85	25.16
880.1	950.1	7.71	7.60	7.62	880.1	39.68	39.89	40.50	25.27	25.34	25.72
900.1	970.1	7.84	7.74	7.73	900.1	39.30	39.54	40.31	25.67	25.82	26.25
920.1	990.1	7.99	7.86	7.85	920.1	38.98	39.29	40.25	25.95	26.19	26.68
940.1	1010.1	8.11	7.96	7.93	940.1	38.66	39.06	40.06	25.96	26.22	26.73
960.1	1030.1	8.25	8.09	8.05	960.1	38.44	38.94	39.98	25.90	26.11	26.58
980.1	1050.1	8.38	8.20	8.15	980.1	38.32	38.87	40.03	26.02	26.19	26.60
1000.1	1070.1	8.58	8.40	8.33	1000.1	38.47	39.05	40.37	26.34	26.46	26.82
1020.1	1090.1	8.74	8.55	8.47	1020.1	38.69	39.19	40.56	26.75	26.84	27.13
1040.1	1110.1	8.90	8.69	8.60	1040.1	39.04	39.42	40.81	27.28	27.35	27.60
1060.1	1130.1	9.06	8.84	8.74	1060.1	39.19	39.53	40.75	27.86	27.87	28.14
1080.1	1150.1	9.27	9.04	8.93	1080.1	39.63	40.03	41.17	28.35	28.32	28.59
1100.1	1170.1	9.52	9.28	9.18	1100.1	40.10	40.56	41.79	28.85	28.76	28.99
1120.1	1190.1	9.71	9.48	9.37	1120.1	40.45	40.85	41.65	29.37	29.26	29.48
1140.1	1210.1	9.88	9.64	9.53	1140.1	40.82	41.22	41.74	29.96	29.81	30.06
1160.1	1230.1	10.07	9.81	9.68	1160.1	41.39	41.68	41.68	30.44	30.33	30.65
1180.1	1250.1	10.30	10.03	9.88	1180.1	42.25	42.34	42.15	30.81	30.74	31.08
1200.1	1270.1	10.56	10.29	10.15	1200.1	42.60	42.58	42.38	31.31	31.22	31.48

REV. X2  
ADE-92MH+  
101230  
Page 1 of 3



IF/RF MICROWAVE COMPONENTS • ISO 9001 ISO 14001 AS 9100 CERTIFIED • RoHS compliant  
P.O. Box 350166, Brooklyn, New York 11235-0003 (718) 934-4500 Fax (718) 332-4661



The Design Engineers Search Engine finds the model you need, Instantly • For detailed performance specs & shopping online see



# Frequency Mixer

# ADE-92MH+

## Typical Performance Data

LO (MHz)	RF (MHz)	IP3 Input (dBm)		
		@LO (dBm)	@LO (dBm)	@LO (dBm)
		+10	+13	+16
270.1	200.1	17.93	22.67	24.21
290.1	220.1	18.62	27.97	28.42
310.1	240.1	16.96	21.09	25.22
330.1	260.1	16.15	17.47	18.62
350.1	280.1	16.68	18.14	19.07
370.1	300.1	17.63	19.87	22.14
390.1	320.1	18.27	21.27	23.95
410.1	340.1	18.76	21.59	23.79
430.1	360.1	19.16	21.36	23.09
450.1	380.1	19.39	21.42	23.30
470.1	400.1	19.62	21.44	23.22
490.1	420.1	19.85	21.45	23.28
510.1	440.1	20.10	21.52	23.23
530.1	460.1	20.67	22.35	24.34
550.1	480.1	21.27	23.21	25.08
570.1	500.1	22.30	24.42	25.97
590.1	520.1	22.90	25.06	27.00
610.1	540.1	23.42	25.17	27.27
630.1	560.1	24.31	25.72	27.70
650.1	580.1	25.68	27.70	28.99
670.1	600.1	27.57	31.09	33.07
690.1	620.1	28.71	35.77	38.52
710.1	640.1	28.63	35.96	36.99
730.1	660.1	28.46	33.54	33.66
750.1	680.1	28.30	36.11	32.85
770.1	700.1	26.13	31.27	31.94
790.1	720.1	24.55	27.73	29.90
810.1	740.1	24.34	26.18	28.46
830.1	760.1	25.79	26.81	28.76
850.1	780.1	29.27	29.23	30.21
870.1	800.1	28.20	31.98	31.63
890.1	820.1	27.96	33.52	32.39
910.1	840.1	28.53	33.03	32.20
930.1	860.1	28.36	34.97	34.61
950.1	880.1	27.70	35.44	38.74
970.1	900.1	27.45	33.43	34.79
990.1	920.1	27.57	30.99	31.60
1010.1	940.1	28.67	31.76	31.62
1030.1	960.1	28.51	35.22	32.71
1050.1	980.1	27.25	36.31	32.36
1070.1	1000.1	25.98	31.35	31.61
1090.1	1020.1	25.24	29.45	31.63
1110.1	1040.1	24.46	27.90	32.50
1130.1	1060.1	23.68	25.81	32.00
1150.1	1080.1	23.10	24.00	27.52
1170.1	1100.1	22.83	22.87	24.95
1190.1	1120.1	22.85	22.28	23.68
1210.1	1140.1	23.62	22.18	23.34
1230.1	1160.1	26.84	22.55	23.55
1250.1	1180.1	25.96	23.72	24.25
1270.1	1200.1	21.24	25.72	25.11

REV. X2  
ADE-92MH+  
101230  
Page 2 of 3



IF/RF MICROWAVE COMPONENTS • ISO 9001 ISO 14001 AS 9100 CERTIFIED • RoHS compliant  
P.O. Box 350166, Brooklyn, New York 11235-0003 (718) 934-4500 Fax (718) 332-4661



The Design Engineers Search Engine finds the model you need, Instantly • For detailed performance specs & shopping online see



# Frequency Mixer

# ADE-92MH+

## Typical Performance Data

RF/LO (MHz)	RF VSWR (:1)			LO VSWR (:1)			IF (MHz)	IF VSWR (:1)		
	@LO (dBm)			@LO (dBm)				@LO (dBm)		
	+10	+13	+16	+10	+13	+16		+10	+13	+16
280.1	2.18	2.19	2.17	10.96	10.96	10.62	0.3	1.03	1.04	1.12
300.1	2.08	2.09	2.12	13.19	13.19	12.80	15.7	1.05	1.06	1.10
320.1	2.03	2.03	2.08	15.67	15.53	15.26	31.1	1.09	1.10	1.13
340.1	1.96	1.99	2.05	17.93	17.75	17.57	46.4	1.13	1.13	1.14
360.1	1.95	2.02	2.07	19.76	19.54	19.11	61.8	1.17	1.16	1.17
380.1	1.95	2.04	2.12	21.20	20.95	20.45	77.2	1.23	1.22	1.22
420.1	1.97	2.06	2.19	23.49	23.18	22.87	92.6	1.29	1.29	1.30
440.1	1.98	2.09	2.22	24.14	23.81	23.81	107.9	1.35	1.36	1.39
480.1	2.10	2.26	2.37	22.58	22.29	22.29	123.3	1.41	1.44	1.46
500.1	2.15	2.30	2.44	21.20	20.95	20.95	138.7	1.46	1.50	1.51
540.1	2.21	2.36	2.48	18.11	17.57	17.93	154.1	1.55	1.58	1.57
560.1	2.30	2.49	2.58	16.26	15.81	16.11	169.4	1.64	1.66	1.67
600.1	2.49	2.65	2.81	12.26	12.01	12.09	184.8	1.72	1.75	1.80
620.1	2.58	2.74	2.92	10.56	10.31	10.50	200.2	1.77	1.82	1.94
660.1	2.69	2.89	3.00	7.70	7.50	7.76	215.6	1.73	1.81	1.97
680.1	2.79	2.93	3.05	6.56	6.39	6.58	231.0	1.65	1.75	1.89
720.1	2.95	3.08	3.26	4.86	4.74	4.89	246.3	1.56	1.67	1.76
740.1	2.98	3.16	3.30	4.28	4.19	4.32	261.7	1.49	1.59	1.65
780.1	3.06	3.16	3.34	3.49	3.45	3.52	277.1	1.46	1.56	1.61
800.1	3.02	3.13	3.32	3.27	3.24	3.31	292.5	1.45	1.54	1.62
840.1	3.07	3.20	3.34	3.11	3.10	3.15	307.8	1.45	1.54	1.65
860.1	3.18	3.28	3.41	3.13	3.13	3.16	323.2	1.47	1.55	1.69
900.1	3.31	3.43	3.60	3.31	3.31	3.35	338.6	1.50	1.58	1.73
920.1	3.34	3.49	3.65	3.44	3.45	3.48	354.0	1.54	1.63	1.77
960.1	3.52	3.62	3.78	3.74	3.76	3.77	369.3	1.59	1.67	1.79
980.1	3.58	3.71	3.89	3.91	3.93	3.94	384.7	1.63	1.71	1.82
1020.1	3.70	3.90	4.03	4.25	4.28	4.27	400.1	1.67	1.75	1.85
1040.1	3.80	3.99	4.09	4.41	4.43	4.41	415.5	1.71	1.80	1.92
1080.1	4.00	4.24	4.33	4.68	4.72	4.70	430.9	1.77	1.87	2.02
1100.1	4.09	4.32	4.43	4.86	4.88	4.84	446.2	1.82	1.93	2.10
1140.1	4.36	4.51	4.66	5.04	5.07	5.06	461.6	1.85	1.97	2.14
1160.1	4.48	4.68	4.86	5.14	5.16	5.14	477.0	1.88	2.01	2.15
1200.1	4.75	4.89	5.16	5.31	5.33	5.33	492.4	1.91	2.04	2.17
							507.7	1.96	2.08	2.23
							523.1	2.03	2.16	2.34
							538.5	2.08	2.23	2.44
							553.9	2.10	2.27	2.48
							569.2	2.13	2.31	2.51
							584.6	2.16	2.34	2.52
							600.0	2.20	2.37	2.54

## Typical Performance Curves

Conversion Loss

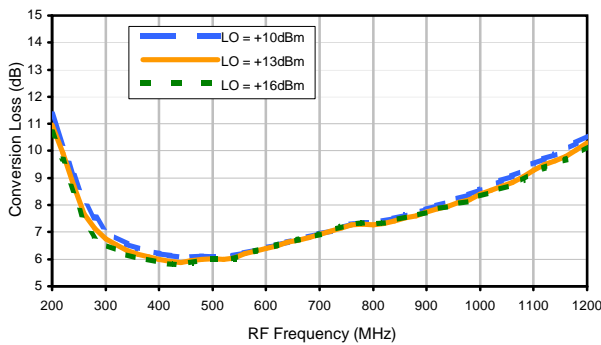

IP3 Input

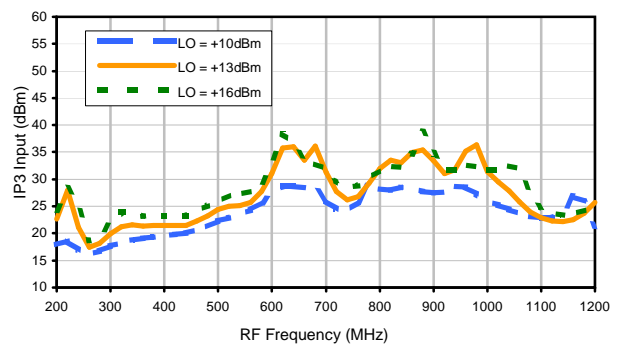

LO-RF Isolation

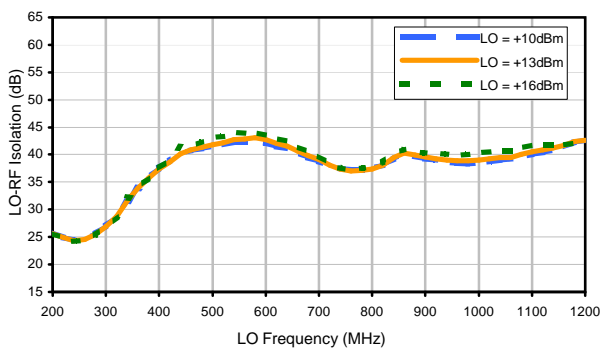

LO-IF Isolation

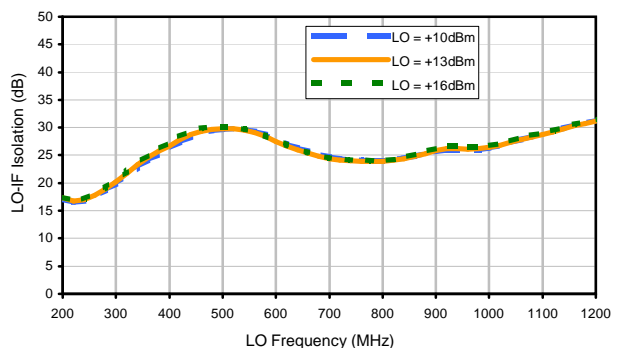

RF VSWR

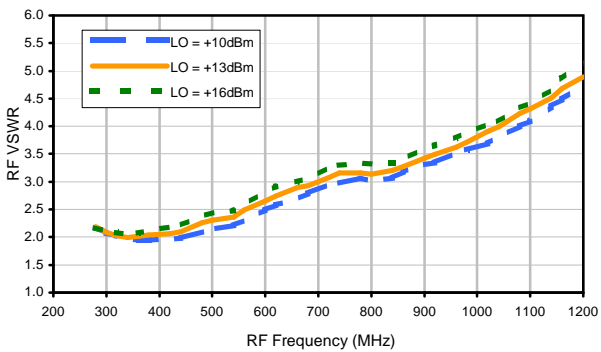

LO VSWR

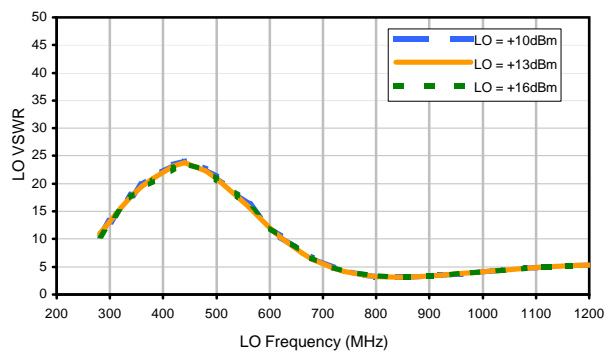

IF VSWR

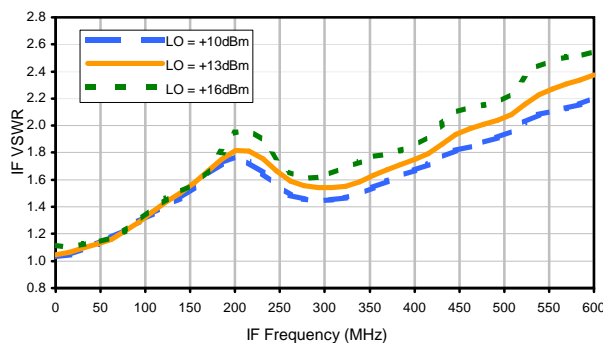

# Case Style

# CD

CD541  
CD542  
CD636  
CD637

## Outline Dimensions

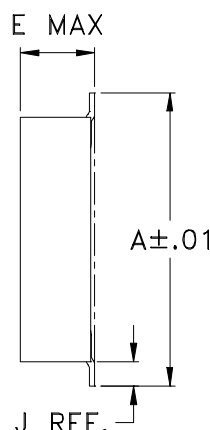
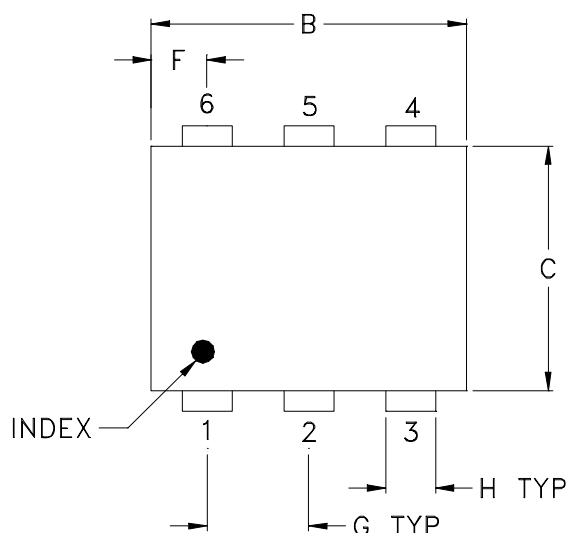

## PCB Land Pattern

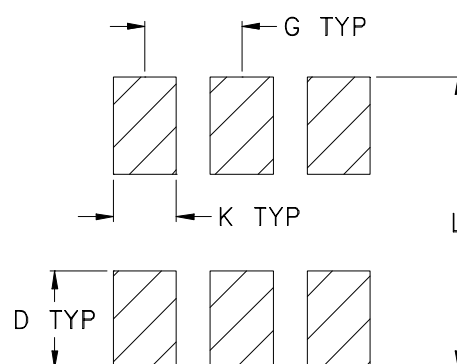

Suggested Layout,  
Tolerance to be within  $\pm .002$

CASE#	A	B	C	D	E	F	G	H	J	K	L	WT, GRAM
CD541					.082 (2.08)							.15
CD542	.272 (6.91)	.310 (7.87)	.220 (5.58)	.100 (2.54)	.112 (2.84)	.055 (1.40)	.100 (2.54)	.030 (0.76)	.026 (0.66)	.065 (1.65)	.300 (7.62)	.20
CD636					.162 (4.11)							.25
CD637					.206 (5.23)							.40

Dimensions are in inches (mm). Tolerances: 2 Pl.  $\pm .01$ ; 3 Pl.  $\pm .005$

### Notes:

- Case material: Plastic.
- Termination finish:
  - For RoHS Case Styles: Tin plate over Nickel plate. All models, (+) suffix.
  - For RoHS-5 Case Styles: Tin-Lead plate. All models, no (+) suffix.

**Mini-Circuits®**

INTERNET <http://www.minicircuits.com>

P.O. Box 350166, Brooklyn, New York 11235-0003 (718) 934-4500 Fax (718) 332-4661

Distribution Centers NORTH AMERICA 800-654-7949 • 417-335-5935 • Fax 417-335-5945 • EUROPE 44-1252-832600 • Fax 44-1252-837010

Mini-Circuits ISO 9001 & ISO 14001 Certified

# Tape & Reel Packaging TR-F34

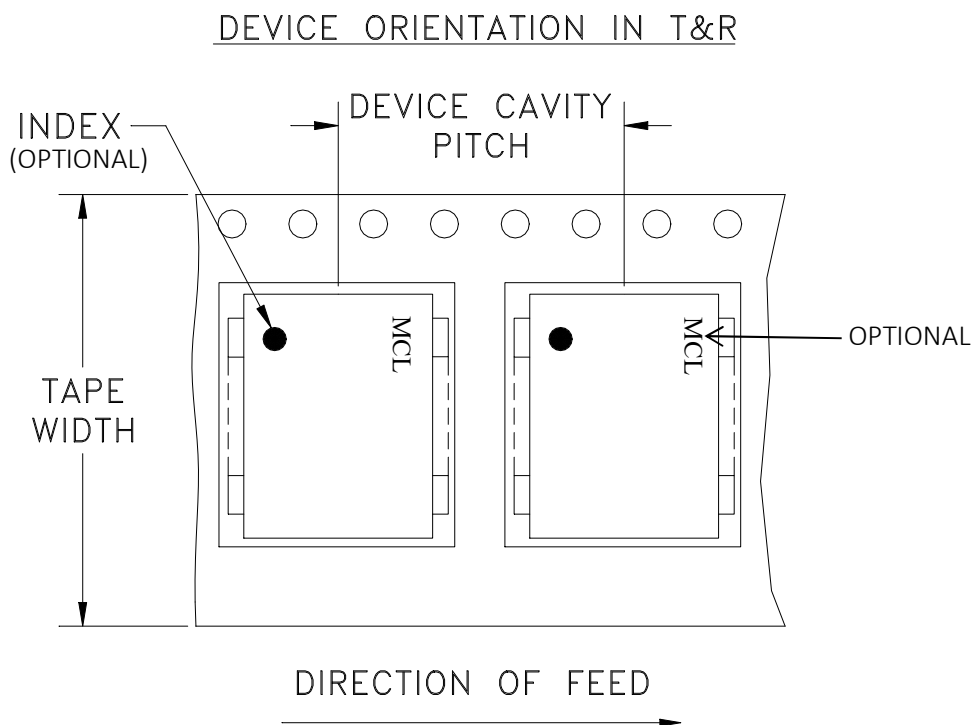

Tape Width, mm	Device Cavity Pitch, mm	Reel Size, inches	Devices per Reel see note	
16	12	7	Small quantity standard (see note)	20
				50
				100
				200
		13	Standard	500
				1000

Note: Availability of small reel quantity varies by model.  
Refer to pricing and availability on individual model dashboard.

Mini-Circuits carrier tape materials provide protection from ESD (Electro-Static Discharge) during handling and transportation. Tapes are static dissipative and comply with industry standards EIA-481/EIA-541.

Go to: [www.minicircuits.com/pages/pdfs/tape.pdf](http://www.minicircuits.com/pages/pdfs/tape.pdf)



INTERNET <http://www.minicircuits.com>

P.O. Box 350166, Brooklyn, New York 11235-0003 (718) 934-4500 Fax (718) 332-4661

Distribution Centers NORTH AMERICA 800-654-7949 • 417-335-5935 • Fax 417-335-5945 • EUROPE 44-1252-832600 • Fax 44-1252-837010

Mini-Circuits ISO 9001 & ISO 14001 Certified

THIRD ANGLE PROJECTION

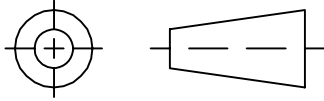

REVISIONS

REV	ECN No.	DESCRIPTION	DATE	DR	AUTH
A	M101143	ADDED "gk" PIN CONNECTION, TT100 CASE STYLE & NOTE 2	10/10/05	MMG	DJ
B	M102713	ADDED "...WITH SMOBC"	01/17/06	MMG	IL
C	M108637	REMOVED "PIN 1", ADDED INDEX ON UNIT	12/01/06	MYG	FL

SUGGESTED MOUNTING CONFIGURATION  
FOR BH292, CD541/542/636/637, TT100/240 CASE  
STYLES, "gk", "ht", "hu", "nd", "w" PIN CONNECTIONS

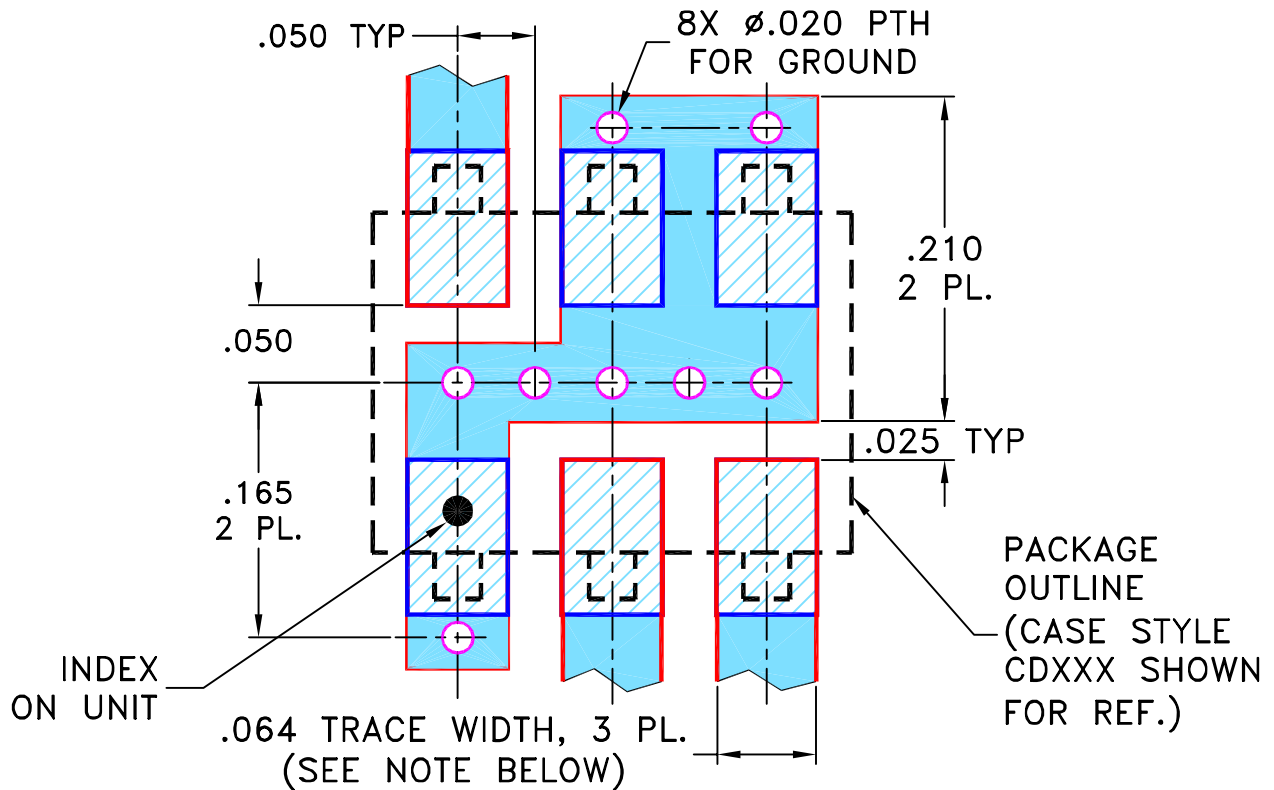

- NOTES:** 1. TRACE WIDTH IS SHOWN FOR ROGERS R04350B WITH DIELECTRIC THICKNESS .030" ± .002"; COPPER: 1/2 OZ. EACH SIDE. FOR OTHER MATERIALS TRACE WIDTH MAY NEED TO BE MODIFIED.  
 2. BOTTOM SIDE OF THE PCB IS CONTINUOUS GROUND PLANE.



DENOTES PCB COPPER LAYOUT WITH SMOBC (SOLDER MASK OVER BARE COPPER)

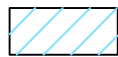

DENOTES COPPER LAND PATTERN FREE OF SOLDER MASK

UNLESS OTHERWISE SPECIFIED

DIMENSIONS ARE IN INCHES

TOLERANCES ON:  
 2 PL DECIMALS ±  
 3 PL DECIMALS ± .005  
 ANGLES ±  
 FRACTIONS ±

	INITIALS	DATE
DRAWN	MMG	07/17/02
CHECKED	WL	08/02/02
APPROVED	DJ	08/05/02



**Mini-Circuits®**

13 Neptune Avenue  
 Brooklyn NY 11235

PL, gk/ht/hu/nd/w, BH292,  
 CD541/542/636/637, TT100/240, TB-03

Mini-Circuits®

THIS DOCUMENT AND ITS CONTENTS ARE THE PROPERTY OF MINI-CIRCUITS. EXCEPT FOR USE EXPRESSLY GRANTED, IN WRITING, TO ITS VENDORS, VENDEE AND THE UNITED STATES GOVERNMENT, MINI-CIRCUITS RESERVES ALL PROPRIETARY DESIGN, USE, MANUFACTURING AND REPRODUCTION RIGHTS THERETO. THESE CONTENTS SHALL NOT BE USED, DUPLICATED OR DISCLOSED TO ANY OUTSIDE PARTY, IN WHOLE OR IN PART, WITHOUT WRITTEN PERMISSION OF MINI-CIRCUITS.

SIZE	CODE IDENT	DRAWING NO:	REV:
A	15542	98-PL-052	C
FILE:	98PL052	SCALE: 8:1	SHEET: 1 OF 1

THIRD ANGLE PROJECTION

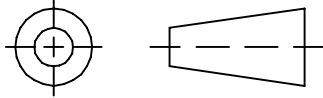

REVISIONS

REV	ECN No.	DESCRIPTION	DATE	DR	AUTH
E	M119737	UPDATED PCB	10.08	MF	AD
F	M127659	UPDATED CARR	06.10	SW	SG
G	M127846	UPDATED SCHEMATIC DIAGRAM	06.10	SW	SG
H	M131840	UPDATED DWG	05.11	MF	AD

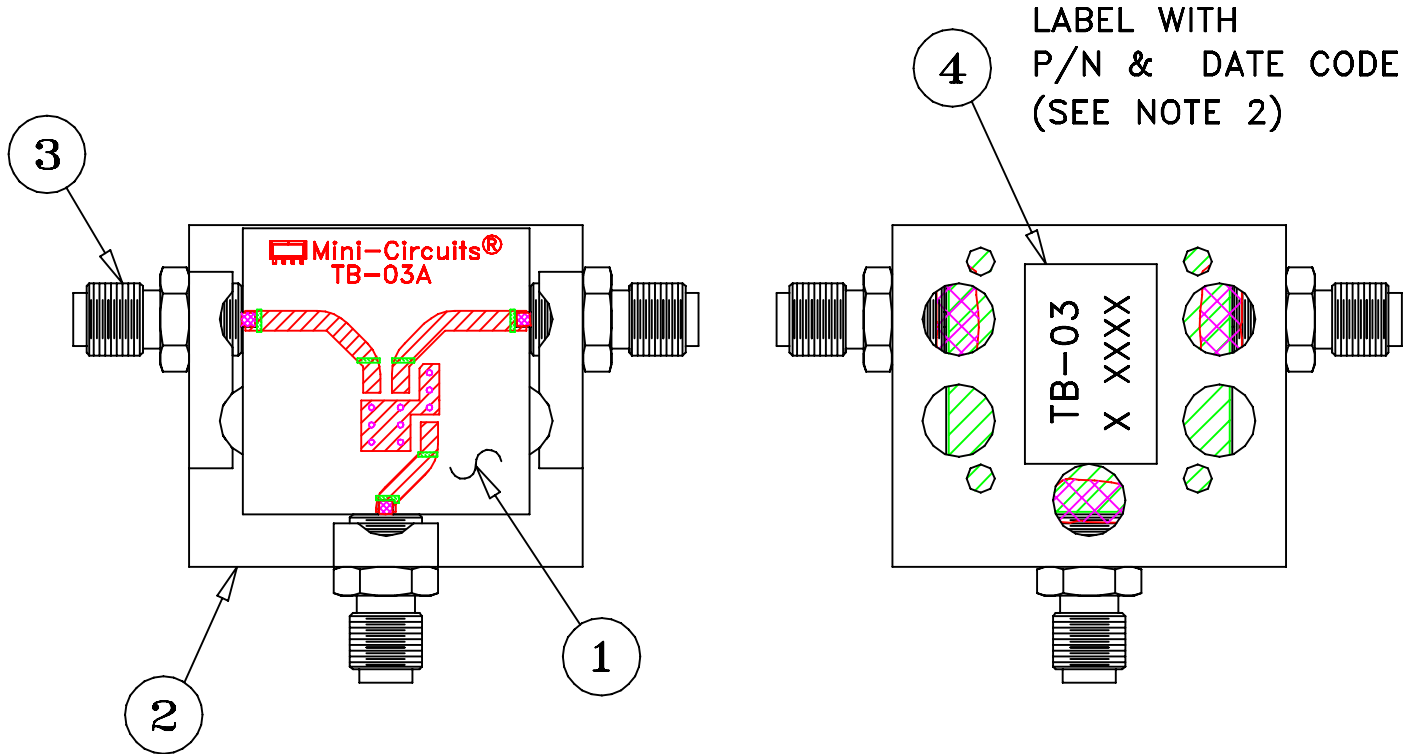

**NOTES:**

1. REFER TO -09 PAGE FOR ITEM DESCRIPTIONS.  
DESIGNATION NUMBERS ON -20 PAGE CORRESPOND TO THE NUMBERS ON -09 PAGE.
2. FOR TEXT HEIGHT & STYLE ON THE LABEL REFER TO: D3-G209.

UNLESS OTHERWISE SPECIFIED	INITIALS		DATE
DIMENSIONS ARE IN INCHES TOLERANCES ON: 2 PL DECIMALS ± 3 PL DECIMALS ± ANGLES ± FRACTIONS ±	DRAWN	S.WOLYNSKI	06.29.99
	CHECKED	SG	07.06.99
	APPROVED	MG	07.10.99

 **Mini-Circuits®** 13 Neptune Avenue  
Brooklyn NY 11235

TB,ADE,CD542/636,06MX01,50

 Mini-Circuits®  
THIS DOCUMENT AND ITS CONTENTS ARE THE PROPERTY OF MINI-CIRCUITS. EXCEPT FOR USE EXPRESSLY GRANTED, IN WRITING, TO ITS VENDORS, VENDEE AND THE UNITED STATES GOVERNMENT, MINI-CIRCUITS RESERVES ALL PROPRIETARY DESIGN, USE, MANUFACTURING AND REPRODUCTION RIGHTS THERETO. THESE CONTENTS SHALL NOT BE USED, DUPLICATED OR DISCLOSED TO ANY OUTSIDE PARTY, IN WHOLE OR IN PART, WITHOUT WRITTEN PERMISSION OF MINI-CIRCUITS.

SIZE A	CODE IDENT 15542	DRAWING NO: TB-03-20	REV: H
FILE: WTB-03	SCALE: 1.5:1	SHEET: 1 OF 2	

# Evaluation Board and Circuit

For Pin Connections and DUT Orientation Refer to  
Data Sheet of the DUT

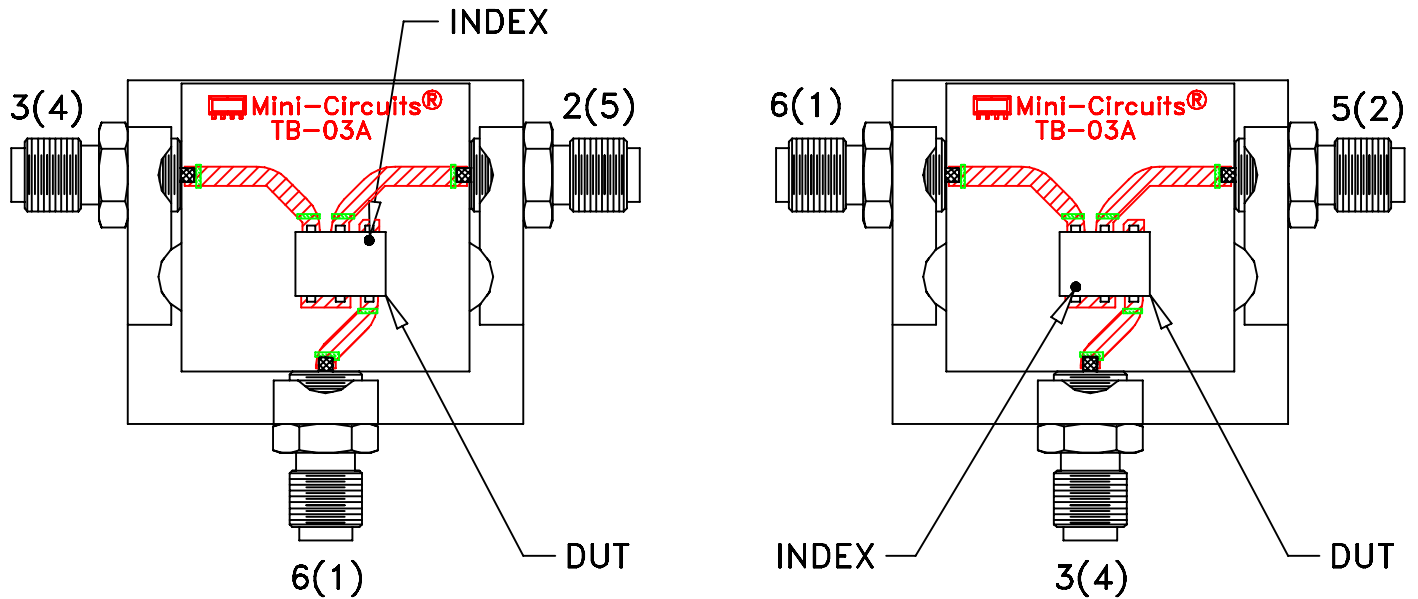

TB-03

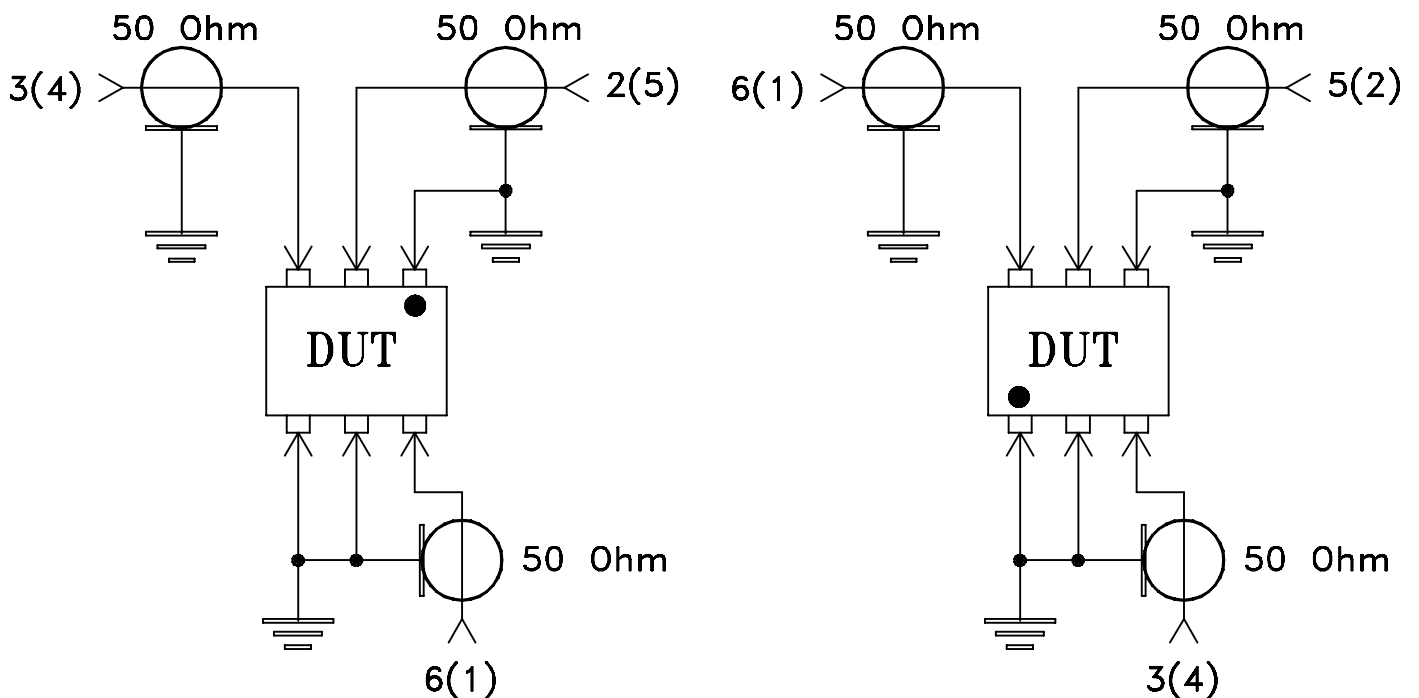

Schematic Diagram

## Notes:

1. 50 Ohm SMA Female connectors.
2. PCB Material: Rogers R04350 or equivalent,  
Dielectric Constant=3.5, Thickness=.030 inch.

 **Mini-Circuits®**

All Mini-Circuits products are manufactured under exacting quality assurance and control standards, and are capable of meeting published specifications after being subjected to any or all of the following physical and environmental test.

Specification	Test/Inspection Condition	Reference/Spec
Operating Temperature	-40° to 85°C Ambient Environment	Individual Model Data Sheet
Storage Temperature	-55° to 100° C Ambient Environment	Individual Model Data Sheet
Humidity	90 to 95% RH, 240 hours, 50°C	MIL-STD-202, Method 103, Condition A, Except 50°C and end-point electrical test done within 12 hours
Thermal Shock	-55° to 100°C, 100 cycles	MIL-STD-202, Method 107, Condition A-3, except +100°C
Solder Reflow Heat	Sn-Pb Eutetic Process: 225°C peak Pb-Free Process 245° - 250°C peak	J-STD-020, Table 4-1, 4-2 and 5-2, Figure 5-1
Solderability	10X Magnification	J-STD-002, 95% Coverage
Vibration (High Frequency)	20g peak, 10-2000 Hz, 12 times in each of three perpendicular directions (total 36)	MIL-STD-202, Method 204, Condition D
Mechanical Shock	50g, 11 ms, 1/2-sine, 18 shocks: 3 each direction, each of 3 axes	MIL-STD-202, Method 213, Condition A
Marking Resistance to Solvents	Isopropyl alcohol + mineral spirits at 25°C; terpene defluxer at 25°C; distilled water + proylene glycol monomethyl ether + monoethanolamine at 63°C to 70°C	MIL-STD-202, Method 215