

Engineering Development Model

Power Splitter/Combiner

2 Way-90°

ADPQ-ED7723/1

Important Note

This model has been designed, built and tested in our engineering department. Performance data represents model capability. At present it is a non-catalog model. On request, we can supply a final specification sheet, part number and price/delivery information.



Please click "Back", and then click "Contact Us" for Applications support.

CASE STYLE : CD542

| ELECTRICAL SPECIFICATIONS 50Ω @ +25°C | | | | | |
|---|---------------|------|-------|-------|-------|
| Parameter | | Min. | Typ. | Max. | Units |
| Frequency | | 544 | | 727 | MHz |
| Isolation | 544 - 727 MHz | 22 | 29 | | dB |
| Insertion Loss | | | | | |
| Average of Coupled Outputs above 3.0 dB | 544 - 727 MHz | | 0.30 | 1.20 | dB |
| Phase Unbalance | 544 - 727 MHz | | 0.836 | 3.000 | deg. |
| Amplitude Unbalance | 544 - 727 MHz | | 0.618 | 2.000 | dB |
| VSWR | SUM Port | | 1.10 | 1.30 | (:1) |
| | OUT Ports | | 1.10 | 1.35 | (:1) |

| MAXIMUM RATINGS | |
|-----------------------|----------------|
| Operating Temperature | -40°C to 85°C |
| Storage Temperature | -55°C to 100°C |

| PIN CONNECTIONS | |
|-----------------|------|
| SUM PORT | 1 |
| PORT 1 | 3 |
| PORT 2 | 6 |
| GND EXT | 2, 5 |
| 50Ω TERMINATION | 4 |

Functional Diagram

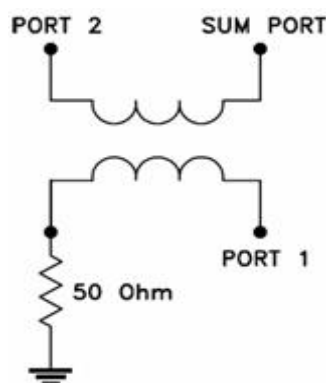

2 Way-90° Power Splitter/Combiner

ADPQ-ED7723/1

Typical Performance Data

| FREQ. (MHz) | TOTAL LOSS ¹ (dB) | | | AMP. UNBAL. (dB) | ISOLATION (dB) | PHASE UNBAL. (deg.) |
|----------------|---------------------------------|------|------|------------------------|-------------------|---------------------------|
| | S-1 | S-2 | AVG. | | | |
| 543.8 | 4.00 | 2.49 | 3.25 | 1.51 | 30.62 | 90.55 |
| 552.5 | 3.91 | 2.54 | 3.23 | 1.37 | 30.56 | 90.56 |
| 561.3 | 3.84 | 2.61 | 3.23 | 1.23 | 30.50 | 90.55 |
| 570.0 | 3.77 | 2.67 | 3.22 | 1.09 | 30.43 | 90.57 |
| 578.8 | 3.69 | 2.73 | 3.21 | 0.96 | 30.36 | 90.62 |
| 587.5 | 3.60 | 2.78 | 3.19 | 0.82 | 30.22 | 90.73 |
| 596.3 | 3.53 | 2.84 | 3.19 | 0.69 | 30.13 | 90.70 |
| 605.0 | 3.47 | 2.92 | 3.20 | 0.55 | 30.00 | 90.67 |
| 613.8 | 3.41 | 2.98 | 3.20 | 0.43 | 29.90 | 90.75 |
| 622.5 | 3.35 | 3.04 | 3.20 | 0.31 | 29.75 | 90.77 |
| 631.3 | 3.29 | 3.10 | 3.20 | 0.19 | 29.62 | 90.83 |
| 640.0 | 3.21 | 3.15 | 3.18 | 0.07 | 29.45 | 90.83 |
| 648.8 | 3.15 | 3.20 | 3.18 | 0.05 | 29.30 | 90.87 |
| 657.5 | 3.10 | 3.27 | 3.19 | 0.17 | 29.14 | 90.96 |
| 666.3 | 3.03 | 3.33 | 3.18 | 0.29 | 28.95 | 90.94 |
| 675.0 | 2.98 | 3.39 | 3.19 | 0.41 | 28.80 | 90.98 |
| 683.8 | 2.93 | 3.45 | 3.19 | 0.52 | 28.62 | 91.02 |
| 692.5 | 2.88 | 3.52 | 3.20 | 0.63 | 28.43 | 91.05 |
| 701.3 | 2.85 | 3.59 | 3.22 | 0.74 | 28.27 | 91.09 |
| 710.0 | 2.81 | 3.67 | 3.24 | 0.86 | 28.09 | 91.12 |
| 718.8 | 2.76 | 3.73 | 3.25 | 0.97 | 27.88 | 91.10 |
| 727.5 | 2.70 | 3.77 | 3.24 | 1.07 | 27.65 | 91.14 |

¹ Total Loss = Insertion Loss + 3dB Splitter Loss



Typical Performance Curves

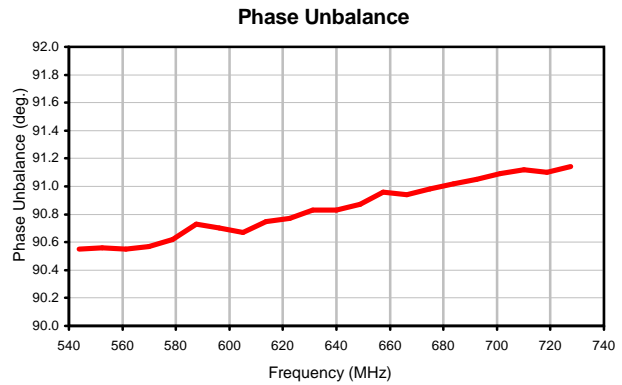
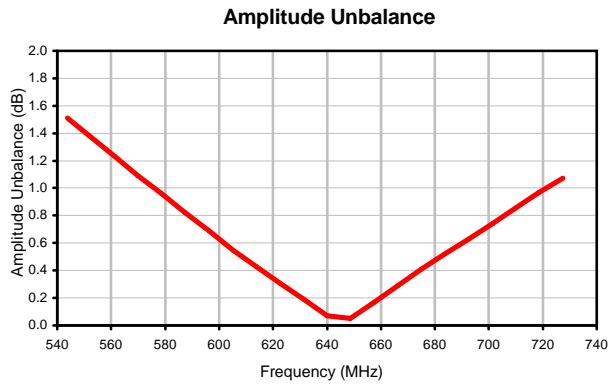
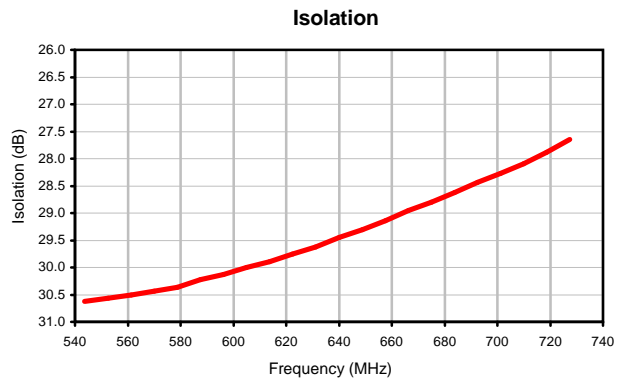
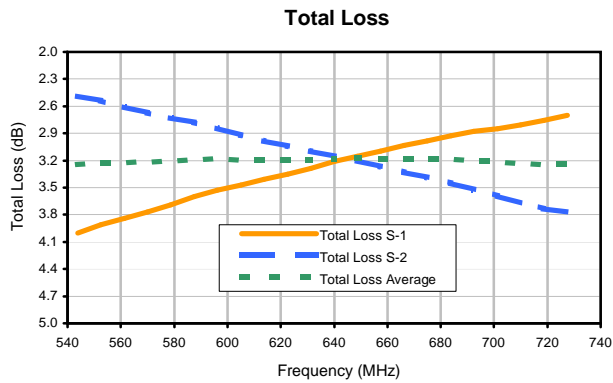

Case Style

CD

CD541
CD542
CD636
CD637

Outline Dimensions



PCB Land Pattern



Suggested Layout,
Tolerance to be within $\pm .002$

| CASE# | A | B | C | D | E | F | G | H | J | K | L | WT, GRAM |
|-------|----------------|----------------|----------------|----------------|----------------|----------------|----------------|----------------|----------------|----------------|----------------|----------|
| CD541 | | | | | .082 (2.08) | | | | | | | .15 |
| CD542 | .272 (6.91) | .310 (7.87) | .220 (5.58) | .100 (2.54) | .112 (2.84) | .055 (1.40) | .100 (2.54) | .030 (0.76) | .026 (0.66) | .065 (1.65) | .300 (7.62) | .20 |
| CD636 | | | | | .162 (4.11) | | | | | | | .25 |
| CD637 | | | | | .206 (5.23) | | | | | | | .40 |

Dimensions are in inches (mm). Tolerances: 2 Pl. $\pm .01$; 3 Pl. $\pm .005$

Notes:

- Case material: Plastic.
- Termination finish:
 - For RoHS Case Styles: Tin plate over Nickel plate. All models, (+) suffix.
 - For RoHS-5 Case Styles: Tin-Lead plate. All models, no (+) suffix.

Mini-Circuits®

INTERNET <http://www.minicircuits.com>

P.O. Box 350166, Brooklyn, New York 11235-0003 (718) 934-4500 Fax (718) 332-4661

Distribution Centers NORTH AMERICA 800-654-7949 • 417-335-5935 • Fax 417-335-5945 • EUROPE 44-1252-832600 • Fax 44-1252-837010

Mini-Circuits ISO 9001 & ISO 14001 Certified

Tape & Reel Packaging TR-F34



| Tape Width, mm | Device Cavity Pitch, mm | Reel Size, inches | Devices per Reel see note | |
|----------------|-------------------------|-------------------|------------------------------------|------|
| 16 | 12 | 7 | Small quantity standard (see note) | 20 |
| | | | | 50 |
| | | | | 100 |
| | | | | 200 |
| | | 13 | Standard | 500 |
| | | | | 1000 |

Note: Availability of small reel quantity varies by model.
Refer to pricing and availability on individual model dashboard.

Mini-Circuits carrier tape materials provide protection from ESD (Electro-Static Discharge) during handling and transportation. Tapes are static dissipative and comply with industry standards EIA-481/EIA-541.

Go to: www.minicircuits.com/pages/pdfs/tape.pdf



INTERNET <http://www.minicircuits.com>

P.O. Box 350166, Brooklyn, New York 11235-0003 (718) 934-4500 Fax (718) 332-4661

Distribution Centers NORTH AMERICA 800-654-7949 • 417-335-5935 • Fax 417-335-5945 • EUROPE 44-1252-832600 • Fax 44-1252-837010

Mini-Circuits ISO 9001 & ISO 14001 Certified

THIRD ANGLE PROJECTION

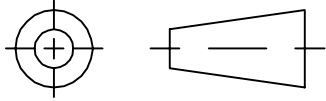

REVISIONS

| REV | ECN No. | DESCRIPTION | DATE | DR | AUTH |
|-----|---------|---|----------|-----|------|
| OR | M82476 | NEW RELEASE | 11/26/02 | MMG | HY |
| A | M102713 | ADDED "ay", "ls" PIN CONNECTIONS, CD636/637 CASE STYLES & "...WITH SMOBC" | 01/17/06 | MMG | IL |

SUGGESTED MOUNTING CONFIGURATION
FOR BH292, CD636/CD637 CASE STYLES,
"ay", "jg", "ls" PIN CONNECTIONS

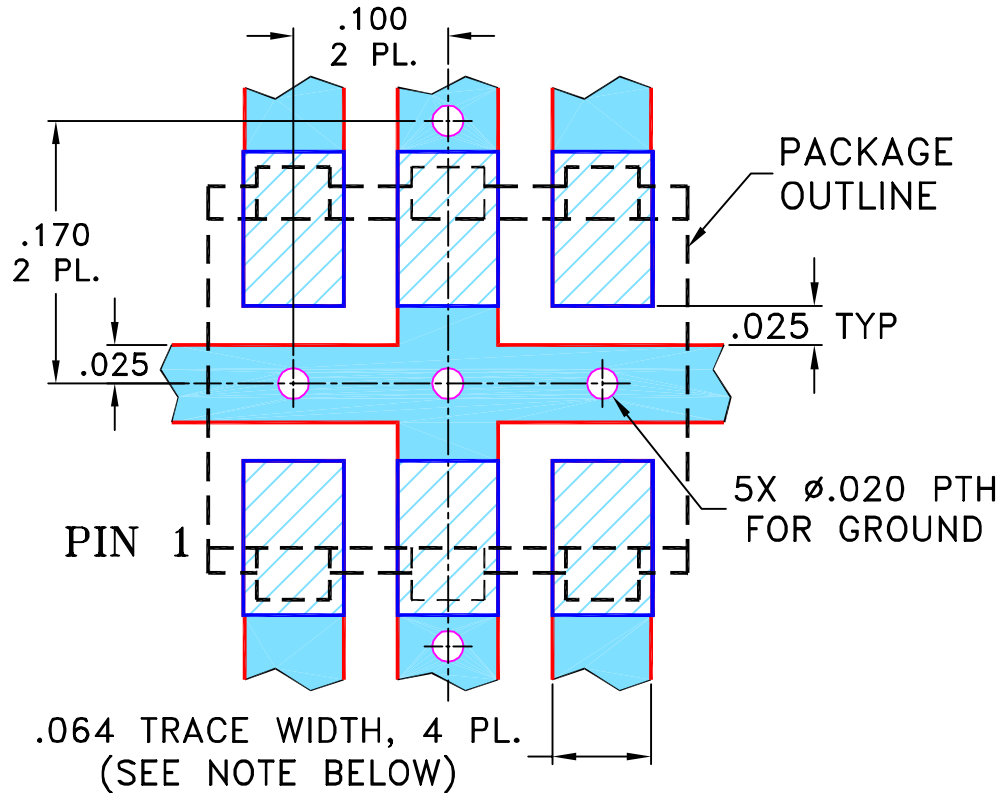

- NOTES: 1. TRACE WIDTH IS SHOWN FOR ROGERS R04350B WITH DIELECTRIC THICKNESS .030" ± .002"; COPPER: 1/2 OZ. EACH SIDE. FOR OTHER MATERIALS TRACE WIDTH MAY NEED TO BE MODIFIED.
 2. BOTTOM SIDE OF THE PCB IS CONTINUOUS GROUND PLANE.



DENOTES PCB COPPER LAYOUT WITH SMOBC (SOLDER MASK OVER BARE COPPER)



DENOTES COPPER LAND PATTERN FREE OF SOLDER MASK

UNLESS OTHERWISE SPECIFIED

INITIALS

DATE

DIMENSIONS ARE IN INCHES

DRAWN

MMG

10/30/02

TOLERANCES ON:

CHECKED

AV

11/26/02

2 PL DECIMALS ± .005

APPROVED

HY

11/26/02

3 PL DECIMALS ±

ANGLES ±

FRACTIONS ±

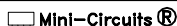

THIS DOCUMENT AND ITS CONTENTS ARE THE PROPERTY OF MINI-CIRCUITS. EXCEPT FOR USE EXPRESSLY GRANTED, IN WRITING, TO ITS VENDORS, VENDEE AND THE UNITED STATES GOVERNMENT, MINI-CIRCUITS RESERVES ALL PROPRIETARY DESIGN, USE, MANUFACTURING AND REPRODUCTION RIGHTS THERETO. THESE CONTENTS SHALL NOT BE USED, DUPLICATED OR DISCLOSED TO ANY OUTSIDE PARTY, IN WHOLE OR IN PART, WITHOUT WRITTEN PERMISSION OF MINI-CIRCUITS.

ASHEETA1.DWG REV:A DATE:01/12/95



Mini-Circuits®

13 Neptune Avenue
Brooklyn NY 11235

PL, ay/jg/lb, BH292, CD636/637,
ADPQ/AMT/JPS, TB-211

SIZE
A

CODE IDENT
15542

DRAWING NO:
98-PL-097

REV:
A

FILE: 98PL097

SCALE: 8:1

SHEET: 1 OF 1

Evaluation Board and Circuit

For Pin Connections refer to Data Sheet of the DUT

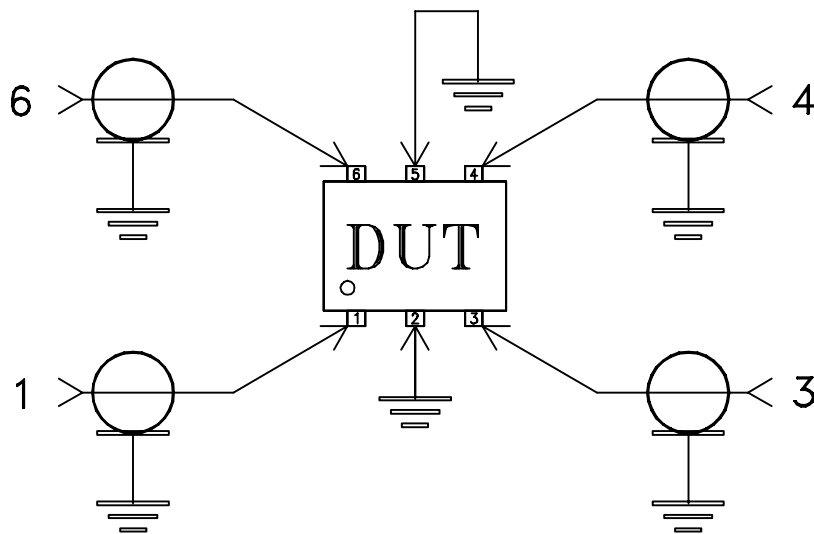
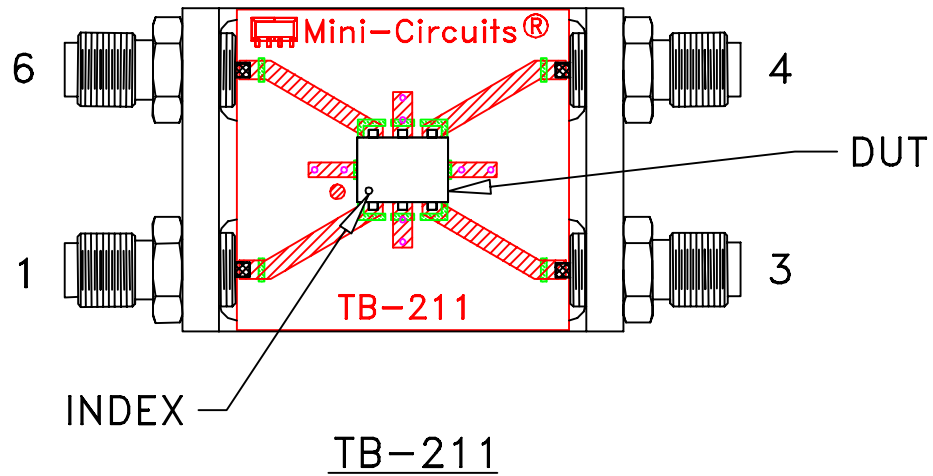

Schematic Diagram

Notes:

1. SMA Female connectors.
2. PCB Material: Rogers R04350 or equivalent,
Dielectric Constant=3.5, Thickness=.030 inch.

 Mini-Circuits®

All Mini-Circuits products are manufactured under exacting quality assurance and control standards, and are capable of meeting published specifications after being subjected to any or all of the following physical and environmental test.

| Specification | Test/Inspection Condition | Reference/Spec |
|--------------------------------|---|--|
| Operating Temperature | -40° to 85°C Ambient Environment | Individual Model Data Sheet |
| Storage Temperature | -55° to 100° C Ambient Environment | Individual Model Data Sheet |
| Humidity | 90 to 95% RH, 240 hours, 50°C | MIL-STD-202, Method 103, Condition A, Except 50°C and end-point electrical test done within 12 hours |
| Thermal Shock | -55° to 100°C, 100 cycles | MIL-STD-202, Method 107, Condition A-3, except +100°C |
| Solder Reflow Heat | Sn-Pb Eutetic Process: 225°C peak Pb-Free Process 245° - 250°C peak | J-STD-020, Table 4-1, 4-2 and 5-2, Figure 5-1 |
| Solderability | 10X Magnification | J-STD-002, 95% Coverage |
| Vibration (High Frequency) | 20g peak, 10-2000 Hz, 12 times in each of three perpendicular directions (total 36) | MIL-STD-202, Method 204, Condition D |
| Mechanical Shock | 50g, 11 ms, 1/2-sine, 18 shocks: 3 each direction, each of 3 axes | MIL-STD-202, Method 213, Condition A |
| Marking Resistance to Solvents | Isopropyl alcohol + mineral spirits at 25°C; terpene defluxer at 25°C; distilled water + proylene glycol monomethyl ether + monoethanolamine at 63°C to 70°C | MIL-STD-202, Method 215 |