



SURFACE MOUNT

RF Transformer

ADT1.5-122+

Mini-Circuits

50Ω 20 to 1200 MHz

FEATURES

- Excellent return loss, 19 dB typ. in 1 dB bandwidth
- Good amplitude unbalance, .25 dB typ. and phase unbalance, 1.0 deg. typ in 1dB bandwidth
- Good insertion loss flatness from 50 MHz to 850 MHz
- Aqueous washable
- Protected under US patent 6,133,525



Generic photo used for illustration purposes only

CASE STYLE: CD542

+RoHS Compliant

The +Suffix identifies RoHS Compliance.
See our website for methodologies and qualifications

APPLICATIONS

- Impedance matching
- Balanced amplifier
- Cable TV

ELECTRICAL SPECIFICATIONS AT 25°C

Parameter	Frequency (MHz)	Min.	Typ.	Max.	Units
Impedance Ratio (Secondary/Primary)			1.5		
Frequency Range		20		1200	MHz
Insertion Loss*	—	—	3	—	dB
	20-1200	—	2	—	
	50-1000	—	1	—	
Amplitude Unbalance	20-1200	—	.35	—	dB
	50-1000	—	.25	—	
Phase Unbalance	20-1200	—	1.2	—	Degree
	50-1000	—	1.0	—	

* Insertion Loss is referenced to mid-band loss, 1 dB typ.

MAXIMUM RATINGS

Parameter	Ratings
Operating Temperature	-40°C to 85°C
Storage Temperature	-55°C to 100°C
RF Power	0.5W
DC Current	30mA

Permanent damage may occur if any of these limits are exceeded.

CONFIGURATION K

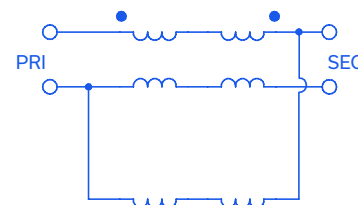

Mini-Circuits

www.minicircuits.com P.O. Box 350166, Brooklyn, NY 11235-0003 (718) 934-4500 sales@minicircuits.com

REV. B
ECO-014934
ADT1.5-122+
DJ/CP/AM
220829

PAGE 1 OF 3



SURFACE MOUNT

RF Transformer

ADT1.5-122+

Mini-Circuits

50Ω 20 to 1200 MHz

PIN CONNECTIONS

PRIMARY DOT, 50Ω unbalanced	3
PRIMARY	1 & 2 connect to GND
SECONDARY DOT, 75Ω balanced	4
SECONDARY, 75Ω balanced	6
NOT USED	5

PRODUCT MARKING: N/A

DEMOBOARD MCL P/N: TB-375
SUGGESTED PCB LAYOUT (PL-257)

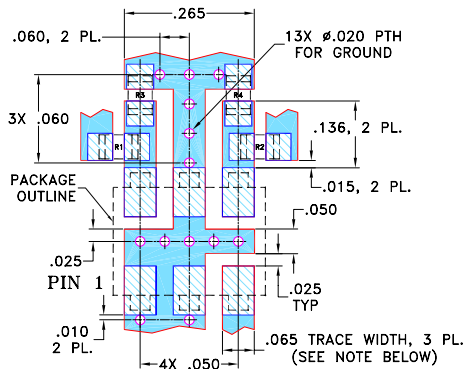

RESISTORS R1-R2: 24.9 Ohm, 0805 SIZE
 RESISTORS R3-R4: 75.0 Ohm, 0805 SIZE

- NOTE:** 1. TRACE WIDTH IS SHOWN FOR ROGERS RO4350B WITH DIELECTRIC THICKNESS 0.030 ± 0.002 ; COPPER: 1/2 OZ. EACH SIDE. FOR OTHER MATERIALS TRACE WIDTH MAY NEED TO BE MODIFIED.
 2. BOTTOM SIDE OF THE PCB IS CONTINUOUS GROUND PLANE.

- DENOTES PCB COPPER LAYOUT WITH SMOBC (SOLDER MASK OVER BARE COPPER)
- DENOTES COPPER LAND PATTERN FREE OF SOLDER MASK

OUTLINE DRAWING

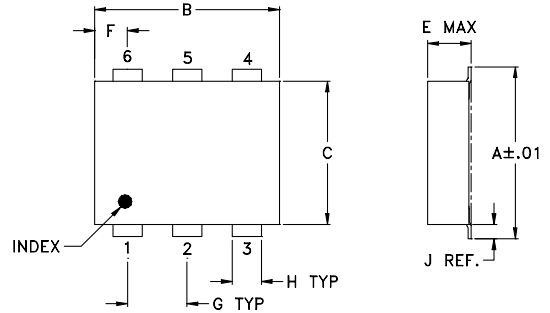

PBC Land Pattern

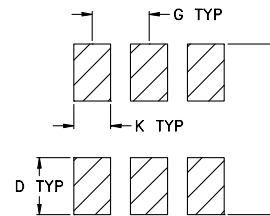

Suggested Layout
 Tolerance to be within $\pm .002$

OUTLINE DIMENSIONS (Inches/mm)

A	B	C	D	E	F	G
.272	.310	.220	.100	.112	.055	.100
6.91	7.87	5.59	2.54	2.84	1.40	2.54
H	J	K	L			wt
.030	.026	.065	.300			grams
0.76	0.66	1.65	7.62			0.20

TAPE & REEL INFORMATION: F34



SURFACE MOUNT

RF Transformer

ADT1.5-122+

Mini-Circuits

50Ω 20 to 1200 MHz

TYPICAL PERFORMANCE DATA

Frequency (MHz)	Insertion Loss (dB)	Return Loss (dB)	Amplitude Unbalance (dB)	Phase Unbalance (deg)
20.00	1.25	19.29	0.01	0.70
40.00	1.17	20.85	0.11	0.53
50.00	1.15	21.10	0.11	0.21
60.00	1.14	21.36	0.07	0.03
100.00	1.11	22.20	0.03	1.13
300.00	1.19	19.59	0.01	1.23
500.00	1.25	19.83	0.21	2.15
850.00	1.37	24.80	0.56	0.69
1000.00	1.51	19.14	0.76	1.45
1200.00	1.95	11.92	0.95	5.56

ADT1.5-122+
INSERTION LOSS

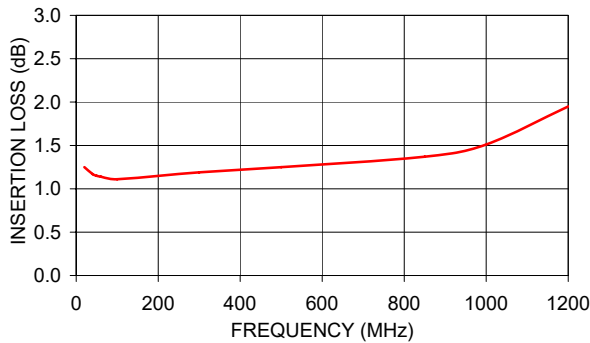

ADT1.5-122+
INPUT RETURN LOSS

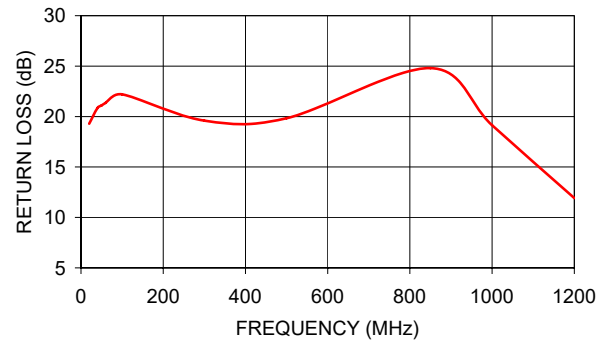

- NOTES**
- A. Performance and quality attributes and conditions not expressly stated in this specification document are intended to be excluded and do not form a part of this specification document.
 - B. Electrical specifications and performance data contained in this specification document are based on Mini-Circuit's applicable established test performance criteria and measurement instructions.
 - C. The parts covered by this specification document are subject to Mini-Circuits standard limited warranty and terms and conditions (collectively, "Standard Terms"); Purchasers of this part are entitled to the rights and benefits contained therein. For a full statement of the standard. Terms and the exclusive rights and remedies thereunder, please visit Mini-Circuits' website at www.minicircuits.com/terms/viewterm.html



Typical Performance Data

FREQUENCY (MHz)	AVERAGE INSERTION LOSS (dB)	INPUT RETURN LOSS (dB)	AMPLITUDE UNBALANCE (dB)	PHASE UNBALANCE (deg)
20	1.25	19.29	0.01	179.30
40	1.17	20.85	0.11	179.47
50	1.15	21.10	0.11	179.79
60	1.14	21.36	0.07	179.97
100	1.11	22.20	0.03	178.87
300	1.19	19.59	0.01	178.77
500	1.25	19.83	0.21	177.85
850	1.37	24.80	0.56	179.31
1000	1.51	19.14	0.76	178.55
1200	1.95	11.92	0.95	174.44

Typical Performance Curves

Average Insertion Loss

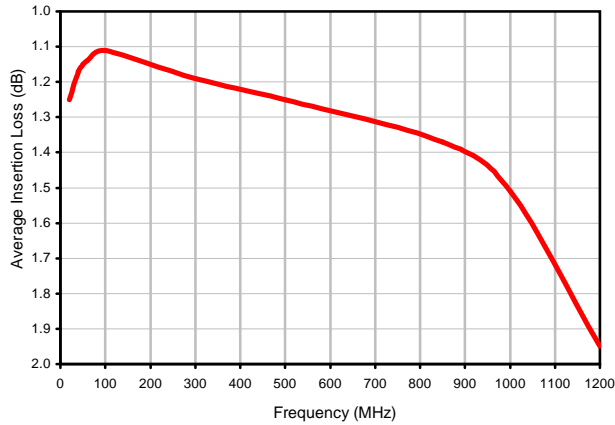

Input Return Loss

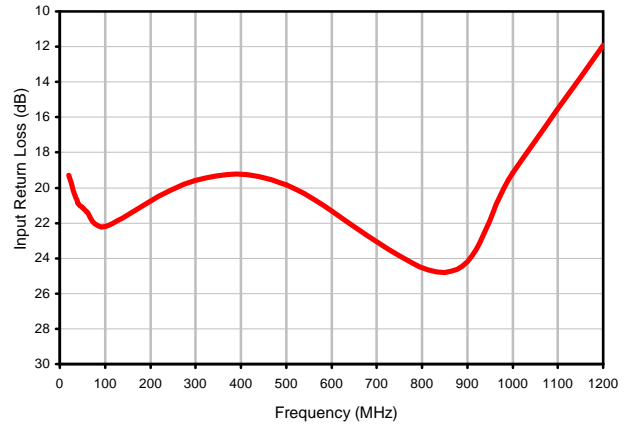

Amplitude Unbalance

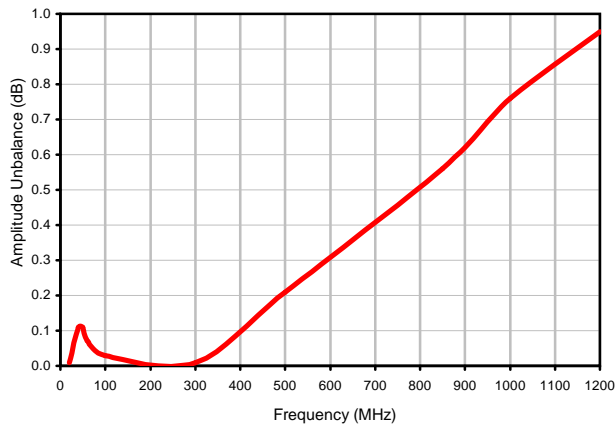

Phase Unbalance

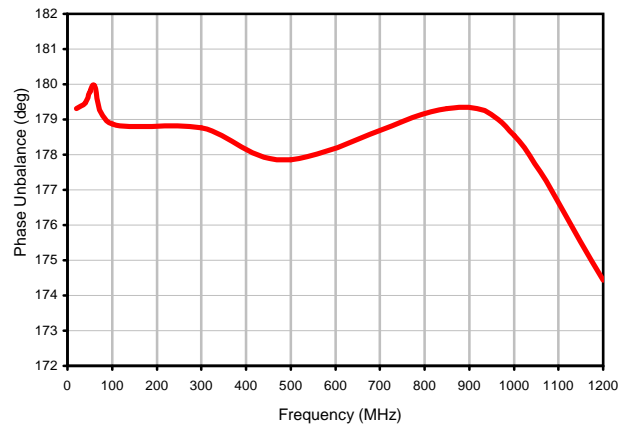

Case Style

CD

CD541
CD542
CD636
CD637

Outline Dimensions

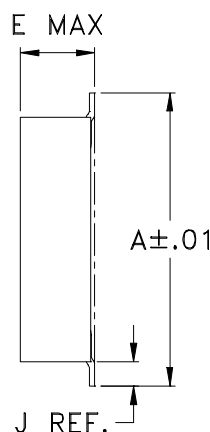
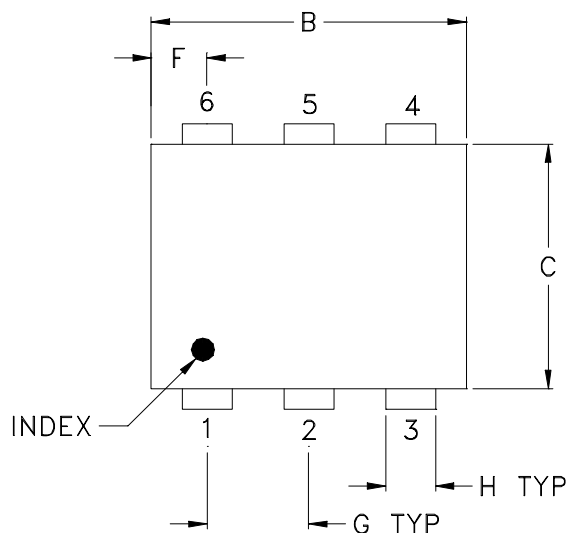

PCB Land Pattern

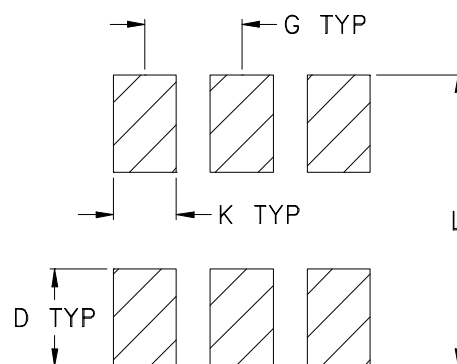

Suggested Layout,
Tolerance to be within $\pm .002$

CASE#	A	B	C	D	E	F	G	H	J	K	L	WT, GRAM
CD541					.082 (2.08)							.15
CD542	.272 (6.91)	.310 (7.87)	.220 (5.58)	.100 (2.54)	.112 (2.84)	.055 (1.40)	.100 (2.54)	.030 (0.76)	.026 (0.66)	.065 (1.65)	.300 (7.62)	.20
CD636					.162 (4.11)							.25
CD637					.206 (5.23)							.40

Dimensions are in inches (mm). Tolerances: 2 Pl. $\pm .01$; 3 Pl. $\pm .005$

Notes:

- Case material: Plastic.
- Termination finish:
 - For RoHS Case Styles: Tin plate over Nickel plate. All models, (+) suffix.
 - For RoHS-5 Case Styles: Tin-Lead plate. All models, no (+) suffix.

Mini-Circuits®

INTERNET <http://www.minicircuits.com>

P.O. Box 350166, Brooklyn, New York 11235-0003 (718) 934-4500 Fax (718) 332-4661

Distribution Centers NORTH AMERICA 800-654-7949 • 417-335-5935 • Fax 417-335-5945 • EUROPE 44-1252-832600 • Fax 44-1252-837010

Mini-Circuits ISO 9001 & ISO 14001 Certified

Tape & Reel Packaging TR-F34

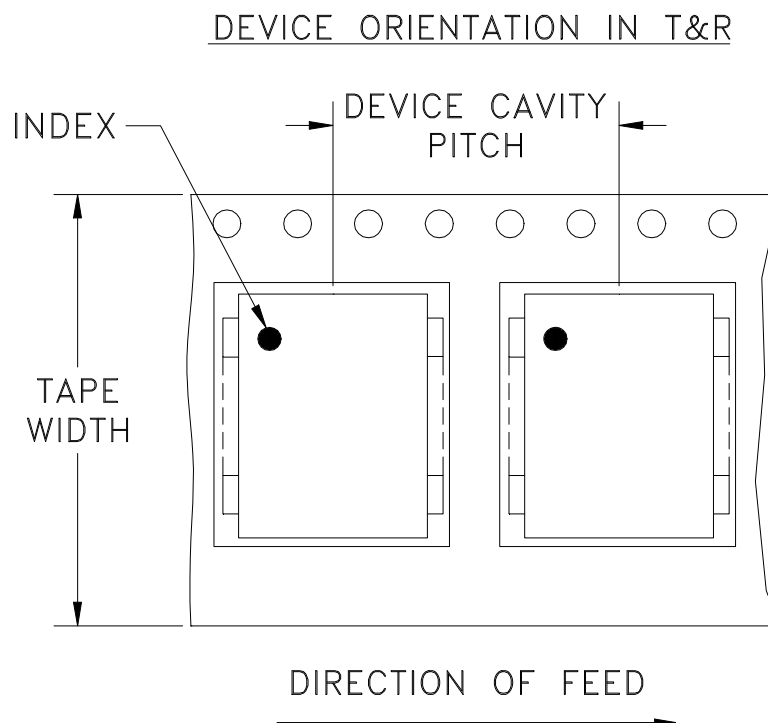

Tape Width, mm	Device Cavity Pitch, mm	Reel Size, inches	Devices per Reel see note	
16	12	7	Small quantity standard (see note)	20
				50
				100
				200
		13	Standard	500
1000				

Note: Availability of small reel quantity varies by model.
Refer to pricing and availability on individual model dashboard.

Mini-Circuits carrier tape materials provide protection from ESD (Electro-Static Discharge) during handling and transportation. Tapes are static dissipative and comply with industry standards EIA-481/EIA-541.

Go to: www.minicircuits.com/pages/pdfs/tape.pdf



INTERNET <http://www.minicircuits.com>

P.O. Box 350166, Brooklyn, New York 11235-0003 (718) 934-4500 Fax (718) 332-4661

Distribution Centers NORTH AMERICA 800-654-7949 • 417-335-5935 • Fax 417-335-5945 • EUROPE 44-1252-832600 • Fax 44-1252-837010

Mini-Circuits ISO 9001 & ISO 14001 Certified

THIRD ANGLE PROJECTION

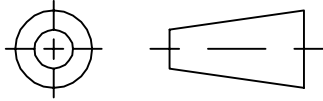

REVISIONS

REV	ECN No.	DESCRIPTION	DATE	DR	AUTH
OR	M108874	NEW RELEASE	01/04/07	AV	DJ

SUGGESTED MOUNTING CONFIGURATION
FOR CD542 CASE STYLE "ru" PIN CONNECTION

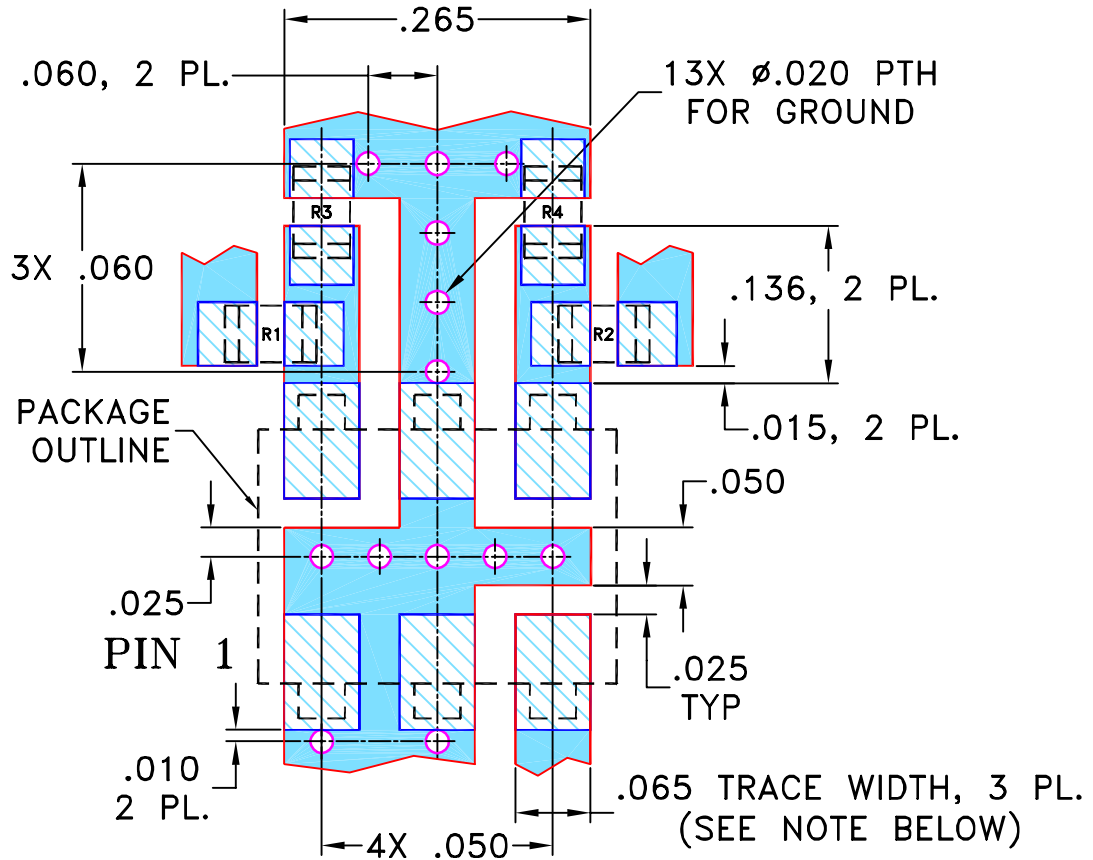

RESISTORS R1-R2: 24.9 Ohm, 0805 SIZE
RESISTORS R3-R4: 75.0 Ohm, 0805 SIZE

- NOTE:** 1. TRACE WIDTH IS SHOWN FOR ROGERS R04350B WITH DIELECTRIC THICKNESS 0.030" ± 0.002"; COPPER: 1/2 OZ. EACH SIDE. FOR OTHER MATERIALS TRACE WIDTH MAY NEED TO BE MODIFIED.
2. BOTTOM SIDE OF THE PCB IS CONTINUOUS GROUND PLANE.

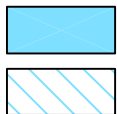

DENOTES PCB COPPER LAYOUT WITH SMOBC (SOLDER MASK OVER BARE COPPER)

DENOTES COPPER LAND PATTERN FREE OF SOLDER MASK

UNLESS OTHERWISE SPECIFIED	INITIALS	DATE
DRAWN	AV	12/13/06
CHECKED	IL	01/04/07
APPROVED	DJ	01/04/07



Mini-Circuits®

13 Neptune Avenue
Brooklyn NY 11235

PL, ru, CD542, ADT1.5-122+, TB-375

Mini-Circuits®
THIS DOCUMENT AND ITS CONTENTS ARE THE PROPERTY OF MINI-CIRCUITS. EXCEPT FOR USE EXPRESSLY GRANTED, IN WRITING, TO ITS VENDORS, VENDEE AND THE UNITED STATES GOVERNMENT, MINI-CIRCUITS RESERVES ALL PROPRIETARY DESIGN, USE, MANUFACTURING AND REPRODUCTION RIGHTS THERETO. THESE CONTENTS SHALL NOT BE USED, DUPLICATED OR DISCLOSED TO ANY OUTSIDE PARTY, IN WHOLE OR IN PART, WITHOUT WRITTEN PERMISSION OF MINI-CIRCUITS.

SIZE	CODE IDENT	DRAWING NO:	REV:
A	15542	98-PL-257	OR

FILE:	SCALE:	SHEET:
98PL257	6:1	1 OF 1

Evaluation Board and Circuit

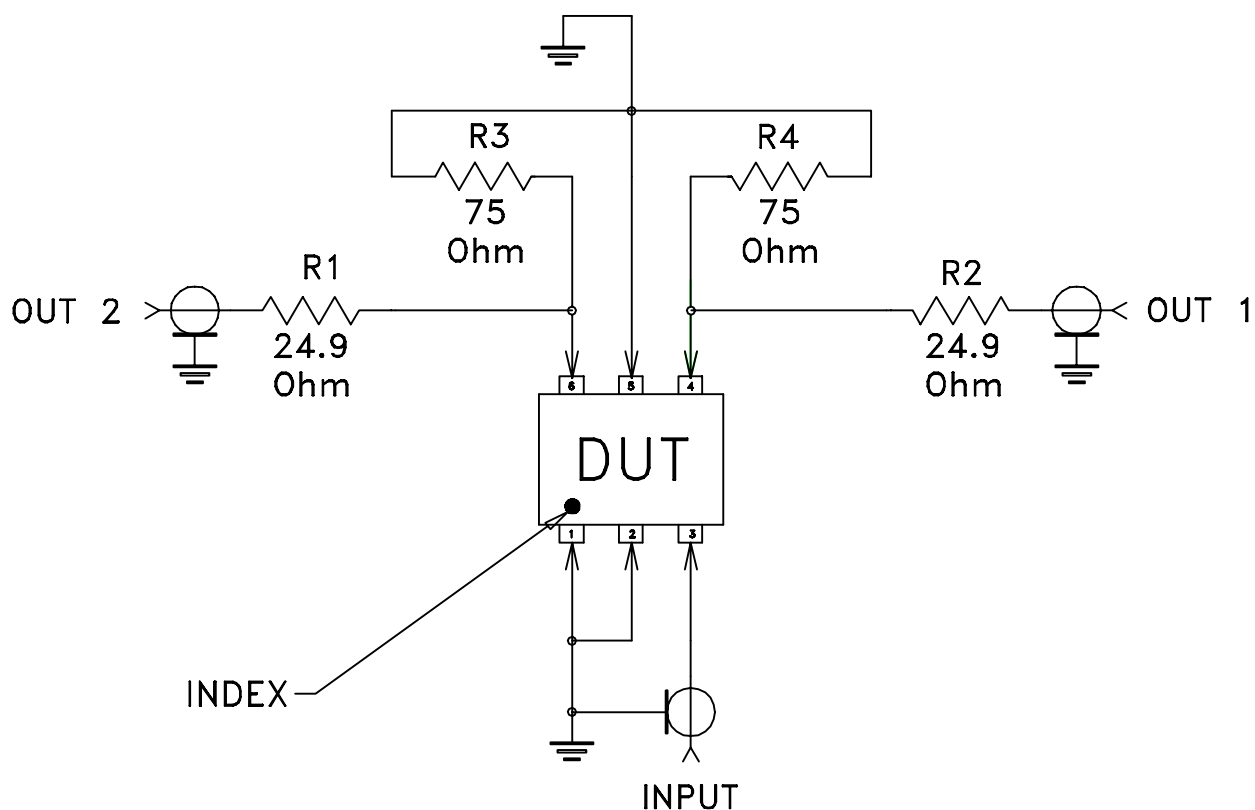
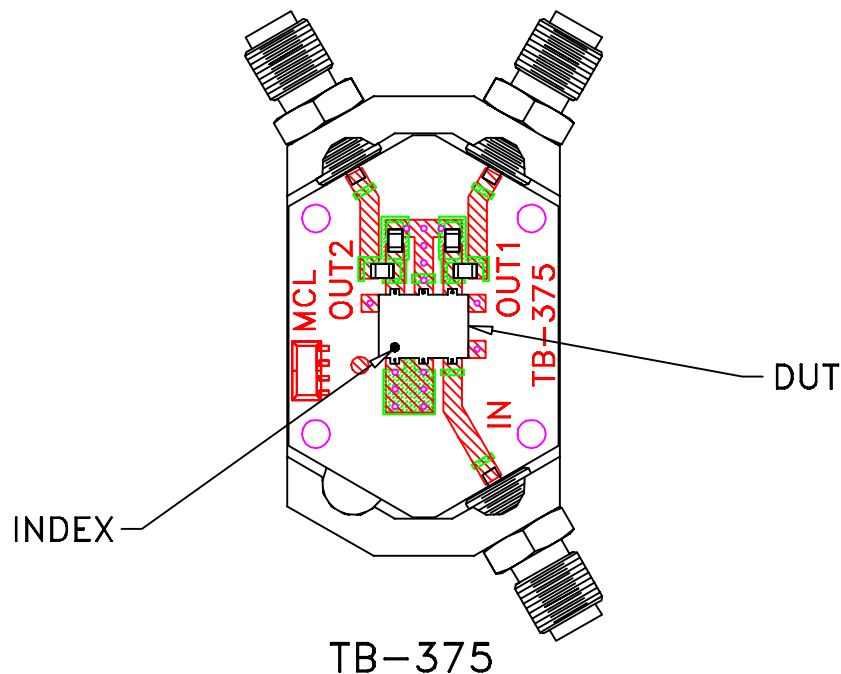

Schematic Diagram

Notes:

1. 50 Ohm SMA Female connectors.
2. PCB Material: Rogers R04350 or its equivalent, Dielectric Constant=3.5, Thickness=.030"

 Mini-Circuits®



All Mini-Circuits products are manufactured under exacting quality assurance and control standards, and are capable of meeting published specifications after being subjected to any or all of the following physical and environmental test.

Specification	Test/Inspection Condition	Reference/Spec
Operating Temperature	-40° to 85°C Ambient Environment	Individual Model Data Sheet
Storage Temperature	-55° to 100° C Ambient Environment	Individual Model Data Sheet
Humidity	90 to 95% RH, 240 hours, 50°C	MIL-STD-202, Method 103, Condition A, Except 50°C and end-point electrical test done within 12 hours
Thermal Shock	-55° to 100°C, 100 cycles	MIL-STD-202, Method 107, Condition A-3, except +100°C
Solder Reflow Heat	Sn-Pb Eutetic Process: 225°C peak Pb-Free Process 245° - 250°C peak	J-STD-020, Table 4-1, 4-2 and 5-2, Figure 5-1
Solderability	10X Magnification	J-STD-002, 95% Coverage
Vibration (High Frequency)	20g peak, 10-2000 Hz, 12 times in each of three perpendicular directions (total 36)	MIL-STD-202, Method 204, Condition D
Mechanical Shock	50g, 11 ms, 1/2-sine, 18 shocks: 3 each direction, each of 3 axes	MIL-STD-202, Method 213, Condition A
Marking Resistance to Solvents	Isopropyl alcohol + mineral spirits at 25°C; terpene defluxer at 25°C; distilled water + proylene glycol monomethyl ether + monoethanolamine at 63°C to 70°C	MIL-STD-202, Method 215