

# Power Splitter/Combiner

## AMT-2+

2 Way-0°/180° 50Ω 50 to 200 MHz



Generic photo used for illustration purposes only  
CASE STYLE: CD636

**+RoHS Compliant**  
The +Suffix identifies RoHS Compliance. See our web site for RoHS Compliance methodologies and qualifications

Available Tape and Reel at no extra cost

Reel Size	Devices/Reel
7"	20, 50, 100, 200
13"	500, 1000

### Maximum Ratings

Operating Temperature	-40°C to 85°C
Storage Temperature	-55°C to 100°C
Power Input (as a splitter)	0.5W max.
Internal Dissipation	0.125W max.

Permanent damage may occur if any of these limits are exceeded.

### Pin Connections

SUM PORT	3
PORT 1	6
PORT 2	4
PORT J	1
GROUND	2,5

### Outline Drawing

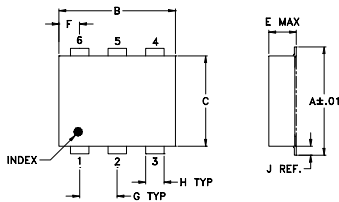

#### PCB Land Pattern

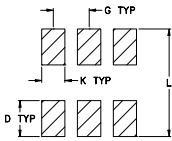

Suggested Layout.  
Tolerance to be within ±0.02

### Outline Dimensions (inch/mm)

A	B	C	D	E	F	G	H	J	K	L	wt
.272	.310	.220	.100	.162	.055	.100	.030	.026	.065	.300	grams
6.91	7.87	5.59	2.54	4.11	1.40	2.54	0.76	0.66	1.65	7.62	0.25

### Demo Board MCL P/N: TB-211 Suggested PCB Layout (PL-097)

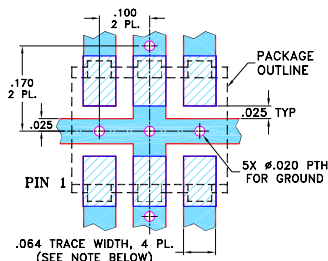

- NOTES: 1. TRACE WIDTH IS SHOWN FOR ROGERS RO4350B WITH DIELECTRIC THICKNESS .030" ± .002"; COPPER: 1/2 OZ. EACH SIDE. FOR OTHER MATERIALS TRACE WIDTH MAY NEED TO BE MODIFIED.  
2. BOTTOM SIDE OF THE PCB IS CONTINUOUS GROUND PLANE.  
■ DENOTES PCB COPPER LAYOUT WITH SMOBC (SOLDER MASK OVER BARE COPPER)  
■ DENOTES COPPER LAND PATTERN FREE OF SOLDER MASK

#### Notes

- A. Performance and quality attributes and conditions not expressly stated in this specification document are intended to be excluded and do not form a part of this specification document.  
B. Electrical specifications and performance data contained in this specification document are based on Mini-Circuits' applicable established test performance criteria and measurement instructions.  
C. The parts covered by this specification document are subject to Mini-Circuits standard limited warranty and terms and conditions (collectively, "Standard Terms"); Purchasers of this part are entitled to the rights and benefits contained therein. For a full statement of the Standard Terms and the exclusive rights and remedies thereunder, please visit Mini-Circuits' website at [www.minicircuits.com/MCLStore/terms.jsp](http://www.minicircuits.com/MCLStore/terms.jsp)

### Features

- low insertion S-1 and S-2, 0.25 dB typ; J-1 and J-2, 0.8 dB typ.
- very good input VSWR, 1.10 typ. and good output VSWR, 1.12 typ.
- excellent amplitude unbalance, 0.1 dB typ.
- excellent phase unbalance, 1 deg. typ.
- high isolation S-J ports and 1-2 ports, 35 dB typ.
- protected under US Patent 6,133,525

### Applications

- satellite
- IF receiver

### Electrical Specifications

FREQ. RANGE (MHz)	ISOLATION (dB)		INSERTION LOSS (dB) ABOVE 3.0 dB		PHASE UNBALANCE (Degrees)	AMPLITUDE UNBALANCE (dB)
	Typ.	Min.	Typ.	Max.	Max.	Max.
f <sub>L</sub> -f <sub>H</sub>	35	20	0.8	1.2	2	0.3

### Typical Performance Data

Freq. (MHz)	Total Loss <sup>1</sup> (dB)		Amplitude Unbal. (dB)	Insertion Loss (dB)		Amplitude Unbal. (dB)	Isolation (dB)		Phase Unbal. (deg.)			VSWR S	VSWR 1	VSWR 2
	S-1	S-2	(S-1)-(S-2)	J-1	J-2	(J-1)-(J-2)	1-2	S-J	(S-1)-(S-2)	(J-1)-(J-2)	(S-1)-(S-2)	(J-1)-(J-2)		
50.00	3.24	3.22	0.02	3.76	3.77	0.00	32.71	44.00	0.05	179.87	1.06	1.14	1.11	
60.00	3.24	3.22	0.02	3.76	3.77	0.00	33.84	42.49	0.06	179.87	1.06	1.14	1.11	
70.00	3.25	3.22	0.03	3.77	3.77	0.01	34.86	41.16	0.02	179.81	1.07	1.15	1.11	
80.00	3.26	3.22	0.04	3.77	3.77	0.01	35.78	40.00	0.05	179.80	1.08	1.16	1.11	
90.00	3.27	3.22	0.05	3.77	3.78	0.02	36.61	38.99	0.04	179.79	1.09	1.17	1.11	
100.00	3.29	3.23	0.05	3.78	3.79	0.01	37.39	38.05	0.02	179.79	1.10	1.18	1.12	
110.00	3.30	3.24	0.06	3.78	3.81	0.02	38.10	37.21	0.05	179.79	1.11	1.19	1.12	
120.00	3.31	3.24	0.07	3.80	3.82	0.02	38.74	36.45	0.02	179.75	1.12	1.21	1.13	
130.00	3.33	3.24	0.09	3.80	3.82	0.02	39.36	35.71	0.00	179.73	1.13	1.22	1.14	
140.00	3.34	3.24	0.10	3.81	3.84	0.03	39.94	35.04	0.02	179.69	1.14	1.23	1.14	
150.00	3.35	3.25	0.11	3.81	3.85	0.03	40.36	34.44	0.02	179.68	1.15	1.24	1.15	
170.00	3.38	3.25	0.13	3.82	3.87	0.05	41.30	33.27	0.09	179.72	1.17	1.27	1.16	
180.00	3.40	3.26	0.14	3.83	3.88	0.05	41.67	32.75	0.06	179.68	1.18	1.28	1.17	
190.00	3.42	3.27	0.16	3.84	3.90	0.06	42.03	32.22	0.10	179.68	1.19	1.30	1.18	
200.00	3.43	3.26	0.17	3.85	3.91	0.06	42.39	31.74	0.15	179.68	1.20	1.32	1.19	

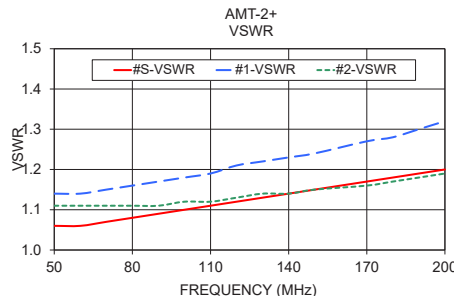
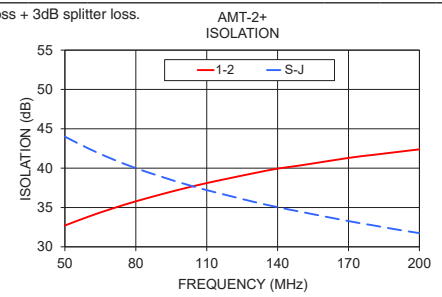
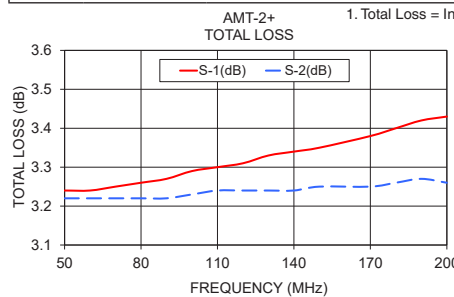

### electrical schematic

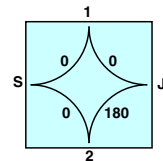

- S-J ports, isolation 40 typical
- Inphase ports, S-1 and S-2 insertion loss 0.2 dB typical
- Amplitude unbalance defined by input S or J ports to output 1 and 2

# 2 Way-0°/180 Power Splitter/Combiner

AMT-2+

## Typical Performance Data

FREQUENCY (MHz)	TOTAL LOSS <sup>1</sup> (dB)				AMPLITUDE UNBALANCE (dB)		ISOLATION (dB)		PHASE UNBALANCE (deg.)		FREQUENCY (MHz)	VSWR (:1)		
	S-1	S-2	J-1	J-2	(S1)-(S2)	(J1)-(J2)	1-2	S-J	(S1)-(S2)	(J1)-(J2)		S	1	2
50.0	3.24	3.22	3.76	3.77	0.02	0.00	32.71	44.00	0.05	179.87	50.0	1.06	1.14	1.11
60.0	3.24	3.22	3.76	3.77	0.02	0.00	33.84	42.49	0.06	179.87	60.0	1.06	1.14	1.11
70.0	3.25	3.22	3.77	3.77	0.03	0.01	34.86	41.16	0.02	179.81	70.0	1.07	1.15	1.11
80.0	3.26	3.22	3.77	3.77	0.04	0.01	35.78	40.00	0.05	179.80	80.0	1.08	1.16	1.11
90.0	3.27	3.22	3.77	3.78	0.05	0.02	36.61	38.99	0.04	179.79	90.0	1.09	1.17	1.11
100.0	3.29	3.23	3.78	3.79	0.05	0.01	37.39	38.05	0.02	179.79	100.0	1.10	1.18	1.12
110.0	3.30	3.24	3.78	3.81	0.06	0.02	38.10	37.21	0.05	179.79	110.0	1.11	1.19	1.12
120.0	3.31	3.24	3.80	3.82	0.07	0.02	38.74	36.45	0.02	179.75	120.0	1.12	1.21	1.13
130.0	3.33	3.24	3.80	3.82	0.09	0.02	39.36	35.71	0.00	179.73	130.0	1.13	1.22	1.14
140.0	3.34	3.24	3.81	3.84	0.10	0.03	39.94	35.04	0.02	179.69	140.0	1.14	1.23	1.14
150.0	3.35	3.25	3.81	3.85	0.11	0.03	40.36	34.44	0.02	179.68	150.0	1.15	1.24	1.15
170.0	3.38	3.25	3.82	3.87	0.13	0.05	41.30	33.27	0.09	179.72	170.0	1.17	1.27	1.16
180.0	3.40	3.26	3.83	3.88	0.14	0.05	41.67	32.75	0.06	179.68	180.0	1.18	1.28	1.17
190.0	3.42	3.27	3.84	3.90	0.16	0.06	42.03	32.22	0.10	179.68	190.0	1.19	1.30	1.18
200.0	3.43	3.26	3.85	3.91	0.17	0.06	42.39	31.74	0.15	179.68	200.0	1.20	1.32	1.19

<sup>1</sup>Total Loss = Insertion Loss + 3dB Splitter Loss



P.O. Box 350166, Brooklyn, New York 11235-0003 (718) 934-4500 • Fax (718) 332-4661 For detailed performance specs & shopping online see Mini-Circuits web site  
 The Design Engineers Search Engine Provides ACTUAL Data Instantly From MINI-CIRCUITS At: [www.minicircuits.com](http://www.minicircuits.com)



IF/RF MICROWAVE COMPONENTS

REV. X2  
 AMT-2+  
 8/4/2010  
 Page 1 of 1

## Typical Performance Curves

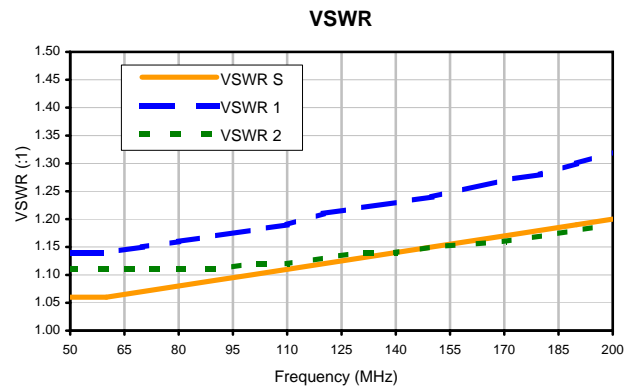
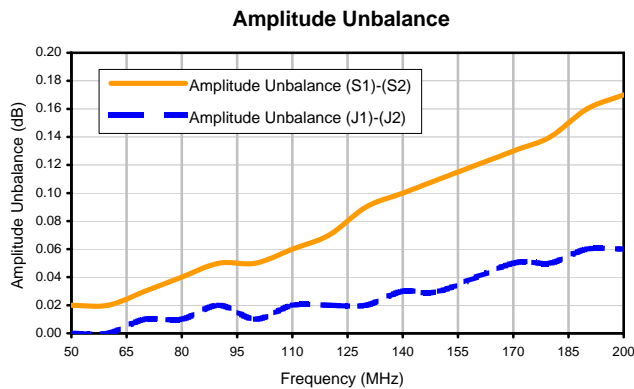
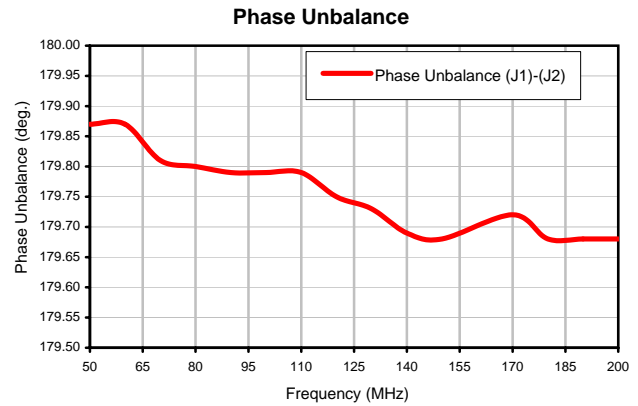
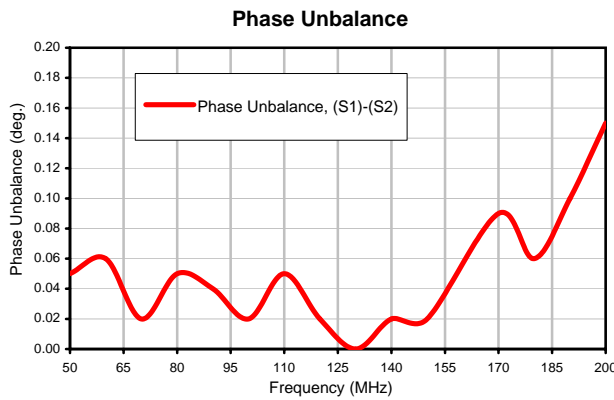
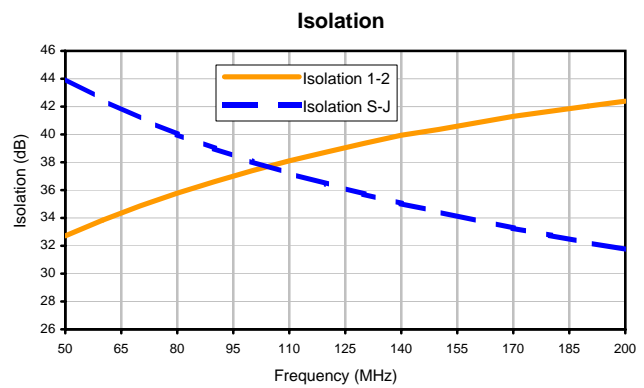
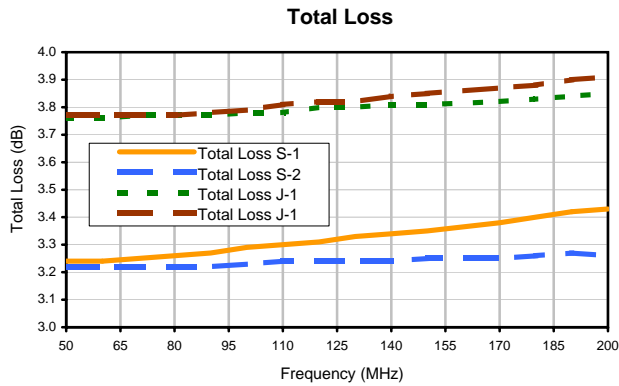

# Case Style

# CD

CD541  
CD542  
CD636  
CD637

## Outline Dimensions

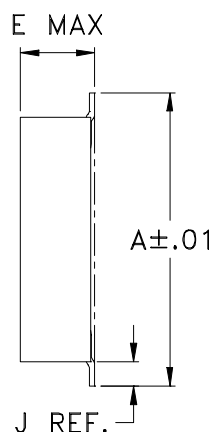
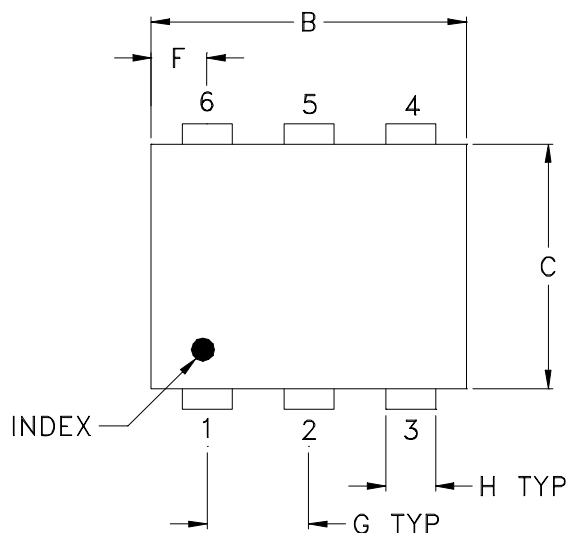

## PCB Land Pattern

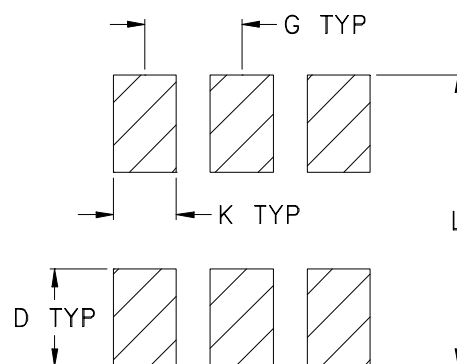

Suggested Layout,  
Tolerance to be within  $\pm .002$

CASE#	A	B	C	D	E	F	G	H	J	K	L	WT, GRAM
CD541					.082 (2.08)							.15
CD542	.272 (6.91)	.310 (7.87)	.220 (5.58)	.100 (2.54)	.112 (2.84)	.055 (1.40)	.100 (2.54)	.030 (0.76)	.026 (0.66)	.065 (1.65)	.300 (7.62)	.20
CD636					.162 (4.11)							.25
CD637					.206 (5.23)							.40

Dimensions are in inches (mm). Tolerances: 2 Pl.  $\pm .01$ ; 3 Pl.  $\pm .005$

### Notes:

- Case material: Plastic.
- Termination finish:
  - For RoHS Case Styles: Tin plate over Nickel plate. All models, (+) suffix.
  - For RoHS-5 Case Styles: Tin-Lead plate. All models, no (+) suffix.

**Mini-Circuits®**

INTERNET <http://www.minicircuits.com>

P.O. Box 350166, Brooklyn, New York 11235-0003 (718) 934-4500 Fax (718) 332-4661

Distribution Centers NORTH AMERICA 800-654-7949 • 417-335-5935 • Fax 417-335-5945 • EUROPE 44-1252-832600 • Fax 44-1252-837010

Mini-Circuits ISO 9001 & ISO 14001 Certified

# Tape & Reel Packaging TR-F34

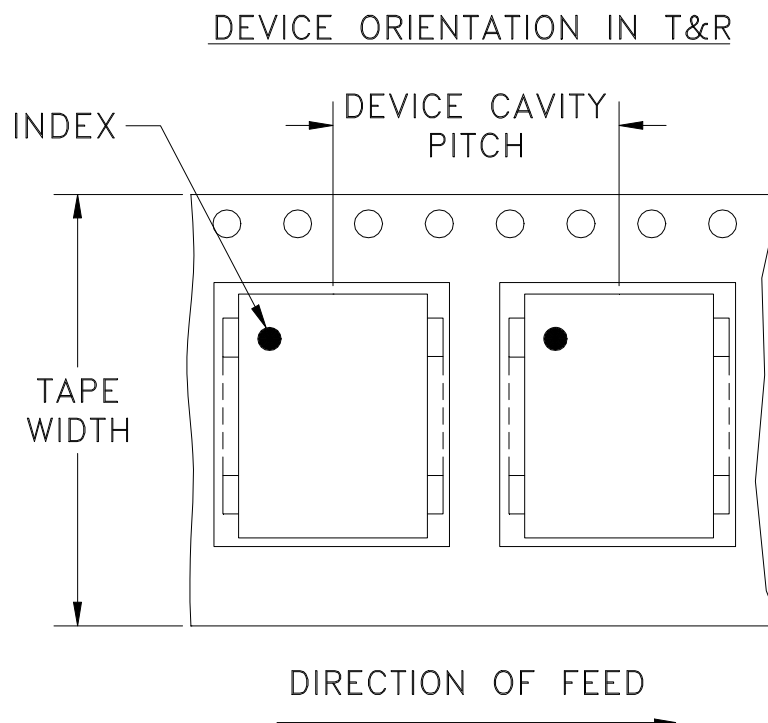

Tape Width, mm	Device Cavity Pitch, mm	Reel Size, inches	Devices per Reel see note	
16	12	7	Small quantity standard (see note)	20
				50
			100	
			200	
		13	Standard	500
				1000

Note: Availability of small reel quantity varies by model.  
Refer to pricing and availability on individual model dashboard.

Mini-Circuits carrier tape materials provide protection from ESD (Electro-Static Discharge) during handling and transportation. Tapes are static dissipative and comply with industry standards EIA-481/EIA-541.

Go to: [www.minicircuits.com/pages/pdfs/tape.pdf](http://www.minicircuits.com/pages/pdfs/tape.pdf)



INTERNET <http://www.minicircuits.com>

P.O. Box 350166, Brooklyn, New York 11235-0003 (718) 934-4500 Fax (718) 332-4661

Distribution Centers NORTH AMERICA 800-654-7949 • 417-335-5935 • Fax 417-335-5945 • EUROPE 44-1252-832600 • Fax 44-1252-837010

Mini-Circuits ISO 9001 & ISO 14001 Certified

THIRD ANGLE PROJECTION

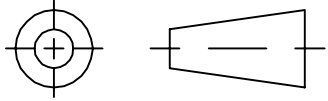

REVISIONS

REV	ECN No.	DESCRIPTION	DATE	DR	AUTH
OR	M82476	NEW RELEASE	11/26/02	MMG	HY
A	M102713	ADDED "ay", "ls" PIN CONNECTIONS, CD636/637 CASE STYLES & "...WITH SMOBC"	01/17/06	MMG	IL

SUGGESTED MOUNTING CONFIGURATION  
FOR BH292, CD636/CD637 CASE STYLES,  
"ay", "jg", "ls" PIN CONNECTIONS

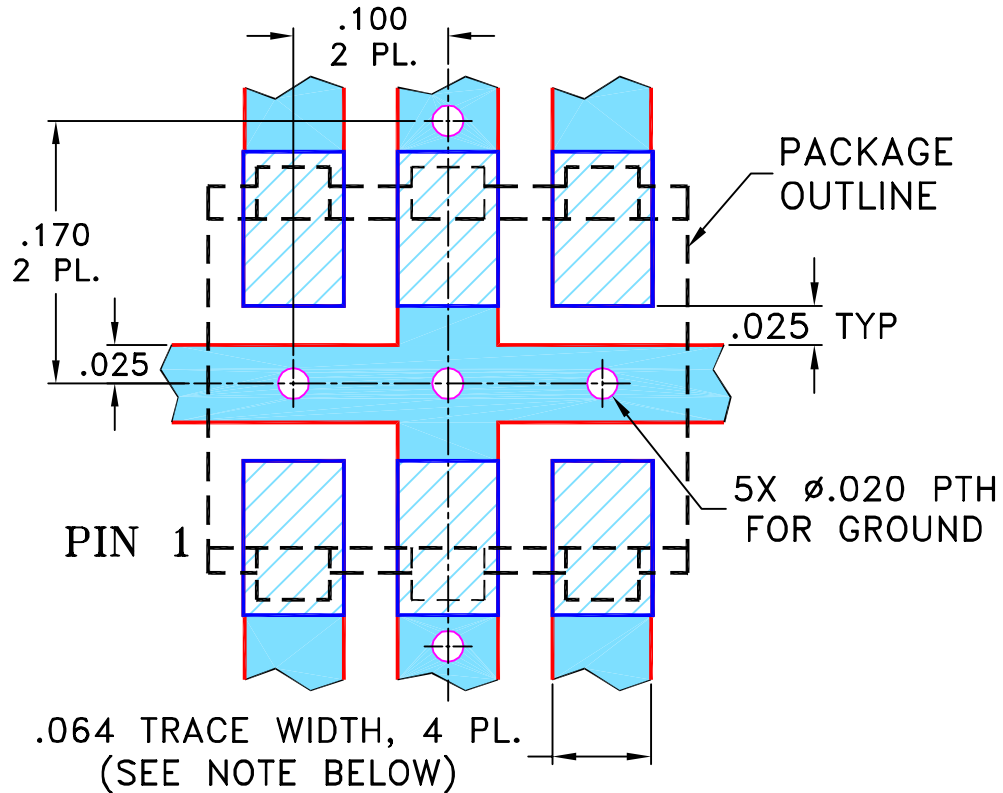

- NOTES: 1. TRACE WIDTH IS SHOWN FOR ROGERS R04350B WITH DIELECTRIC THICKNESS .030" ± .002"; COPPER: 1/2 OZ. EACH SIDE. FOR OTHER MATERIALS TRACE WIDTH MAY NEED TO BE MODIFIED.  
 2. BOTTOM SIDE OF THE PCB IS CONTINUOUS GROUND PLANE.



DENOTES PCB COPPER LAYOUT WITH SMOBC (SOLDER MASK OVER BARE COPPER)



DENOTES COPPER LAND PATTERN FREE OF SOLDER MASK

UNLESS OTHERWISE SPECIFIED

INITIALS

DATE

DIMENSIONS ARE IN INCHES

DRAWN

MMG

10/30/02

TOLERANCES ON:

CHECKED

AV

11/26/02

2 PL DECIMALS ± .005

APPROVED

HY

11/26/02

3 PL DECIMALS ±

ANGLES ±

FRACTIONS ±

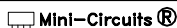

Mini-Circuits®

13 Neptune Avenue  
 Brooklyn NY 11235

PL, ay/jg/lb, BH292, CD636/637,  
 ADPQ/AMT/JPS, TB-211

SIZE  
 A

CODE IDENT  
 15542

DRAWING NO:  
 98-PL-097

REV:  
 A

FILE: 98PL097

SCALE: 8:1

SHEET: 1 OF 1

ASHEETA1.DWG REV:A DATE:01/12/95

THIS DOCUMENT AND ITS CONTENTS ARE THE PROPERTY OF MINI-CIRCUITS. EXCEPT FOR USE EXPRESSLY GRANTED, IN WRITING, TO ITS VENDORS, VENDEE AND THE UNITED STATES GOVERNMENT, MINI-CIRCUITS RESERVES ALL PROPRIETARY DESIGN, USE, MANUFACTURING AND REPRODUCTION RIGHTS THERETO. THESE CONTENTS SHALL NOT BE USED, DUPLICATED OR DISCLOSED TO ANY OUTSIDE PARTY, IN WHOLE OR IN PART, WITHOUT WRITTEN PERMISSION OF MINI-CIRCUITS.

# Evaluation Board and Circuit

For Pin Connections refer to Data Sheet of the DUT

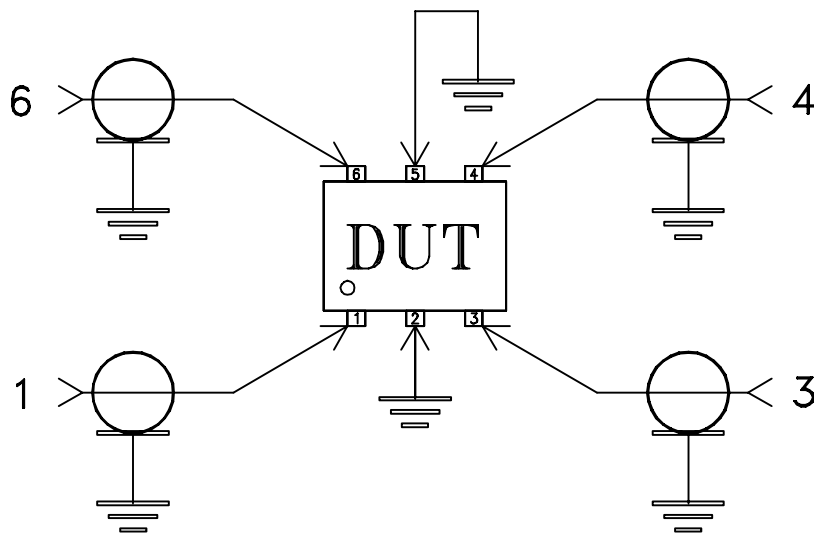
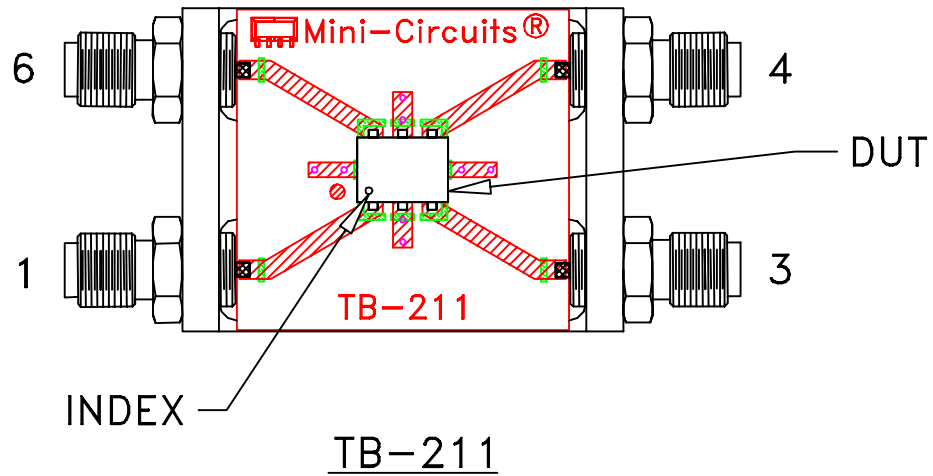

Schematic Diagram

## Notes:

1. SMA Female connectors.
2. PCB Material: Rogers R04350 or equivalent,  
Dielectric Constant=3.5, Thickness=.030 inch.

 Mini-Circuits®

All Mini-Circuits products are manufactured under exacting quality assurance and control standards, and are capable of meeting published specifications after being subjected to any or all of the following physical and environmental test.

Specification	Test/Inspection Condition	Reference/Spec
Operating Temperature	-40° to 85°C Ambient Environment	Individual Model Data Sheet
Storage Temperature	-55° to 100° C Ambient Environment	Individual Model Data Sheet
Humidity	90 to 95% RH, 240 hours, 50°C	MIL-STD-202, Method 103, Condition A, Except 50°C and end-point electrical test done within 12 hours
Thermal Shock	-55° to 100°C, 100 cycles	MIL-STD-202, Method 107, Condition A-3, except +100°C
Solder Reflow Heat	Sn-Pb Eutetic Process: 225°C peak Pb-Free Process 245° - 250°C peak	J-STD-020, Table 4-1, 4-2 and 5-2, Figure 5-1
Solderability	10X Magnification	J-STD-002, 95% Coverage
Vibration (High Frequency)	20g peak, 10-2000 Hz, 12 times in each of three perpendicular directions (total 36)	MIL-STD-202, Method 204, Condition D
Mechanical Shock	50g, 11 ms, 1/2-sine, 18 shocks: 3 each direction, each of 3 axes	MIL-STD-202, Method 213, Condition A
Marking Resistance to Solvents	Isopropyl alcohol + mineral spirits at 25°C; terpene defluxer at 25°C; distilled water + proylene glycol monomethyl ether + monoethanolamine at 63°C to 70°C	MIL-STD-202, Method 215