



MMIC DIE

Wideband Amplifier **AVA-26453LN-D+**

50Ω 26 to 45 GHz

THE BIG DEAL

- Single Supply Voltage, +3V and 80 mA
- Wide Bandwidth, 26 to 45 GHz
- Low Noise Figure, Typ. 2.9 dB at 35 GHz
- Output IP3, Typ. +19.2 dBm at 35 GHz

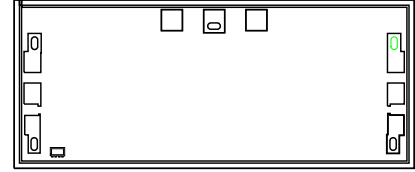

+RoHS Compliant
 The +Suffix identifies RoHS Compliance.
 See our website for methodologies and qualifications

SEE ORDERING INFORMATION ON THE LAST PAGE

APPLICATIONS

- 5G MIMO and Back Haul Radio Systems
- Satellite Ka-band Communications
- Test and Measurement Equipment
- Radar, EW, and ECM Defense Systems
- Excellent alternative to the Broadcom AMMC-6241^{A,B}

PRODUCT OVERVIEW

The AVA-26453LN-D+ is a high gain low noise MMIC amplifier that operates from 26 to 45 GHz. The MMIC is fabricated on a high performance pHEMT process to enable high gain and low noise figure over a wide bandwidth in the millimeter wave region. This MMIC amplifier is impedance matched for a 50 ohm system, has unconditional stability, and operates from a single +3V supply voltage. The AVA-26453LN-D+ can be used as a first or second stage low noise amplifier for a wide variety of millimeter wave systems including 5G, Backhaul Radio, and Ka Band Satellite Systems.

KEY FEATURES

Features	Advantages
High Gain, Typ. 22.2 dB at 35 GHz.	Suitable for wide bandwidth applications.
P1dB and Output IP3, <ul style="list-style-type: none"> • P1dB Typ. +11.1 dBm at 35 GHz • OIP3 Typ. +19.2 dBm at 35 GHz 	Suitable as a driver amplifier in receiver/transmitter chains.
Unpackaged Die	Suitable for chip and wire hybrid assemblies.

A. Suitability for model replacement within a particular system must be determined by and is solely the responsibility of the customer based on, among other things, electrical performance criteria, stimulus conditions, application, and compatibility with other components and environmental conditions and stresses.

B. The AMMC-6241 part number is used for identification and comparison purposes only.



**MMIC DIE**

Wideband Amplifier **AVA-26453LN-D+**

Mini-Circuits

50Ω 26 to 45 GHz

ELECTRICAL SPECIFICATIONS¹ AT 25°C, Zo=50Ω AND, VDD=+3V, IDD=80mA, UNLESS NOTED OTHERWISE

Parameter	Condition (GHz)	Min.	Typ.	Max.	Units
Frequency Range		26		45	GHz
Gain	26		21.6		dB
	30		21.1		
	35		22.2		
	40		18.1		
	45		14.7		
Input Return Loss	26		8.9		dB
	30		9.3		
	35		11.9		
	40		8.1		
	45		5.3		
Output Return Loss	26		9.3		dB
	30		11.3		
	35		14.1		
	40		10.7		
	45		10.9		
Isolation	26-45		53.1		dB
Output Power at 1 dB Compression	26		+11		dBm
	30		+11.6		
	35		+11.1		
	40		+11.1		
	45		+10.2		
Output Third-Order Intercept Point (Pout = -5dBm/Tone)	26		+19.8		dBm
	30		+19.6		
	35		+19.2		
	40		+19.1		
	45		+18.9		
Noise Figure	26		2.6		dB
	30		2.7		
	35		2.9		
	40		3.4		
	45		3.7		
Device Operating Voltage (VDD)		+2.75	+3	+3.25	V
Device Operating Current (IDD)			80	108	mA
Device Current Variation Vs. Temperature ²			-15.384		uA/°C
Device Current Variation Vs. Voltage ³			0.0333		mA/mV
Thermal Resistance, Junction-to-Ground Lead (ΘJC)			42.5		°C/W

1. Die is attached and measured on Mini-Circuits die characterization board. See Characterization & Application Circuits (Fig.1 and Fig.2)

2. Device Current Variation vs. Temperature = (Current in mA at +85°C - Current in mA at -45°C)/+130°C

3. Device Current Variation vs. Voltage = (Current in mA at +3.25V - Current in mA at +2.75V)/((+3.25V-2.75V)*1000mA/mV)



MMIC DIE

Wideband Amplifier **AVA-26453LN-D+**

Mini-Circuits

50Ω 26 to 45 GHz

MAXIMUM RATINGS⁴

Parameter	Ratings
Operating Case Temperature	-45°C to +85°C
Storage Temperature	+20°C to +35°C
Total Power Dissipation	1.2W
Junction Temperature ⁵	+150°C
RF Input Power	+26 dBm (5 min max) +23 dBm (continuous)
DC Voltage at VDD	+4.5V
Current IDD	130 mA

4. Permanent damage may occur if any of these limits are exceeded. Electrical maximum ratings are not intended for continuous normal operation.

5. $T_j = +85^\circ\text{C} + (V_{DD}) \cdot (I_{DD}) \cdot (\Theta_{JC}) = +95^\circ\text{C}$. Keeping T_j below +95°C will keep typical MTTF > 100 years.

SIMPLIFIED SCHEMATIC AND PAD DESCRIPTION

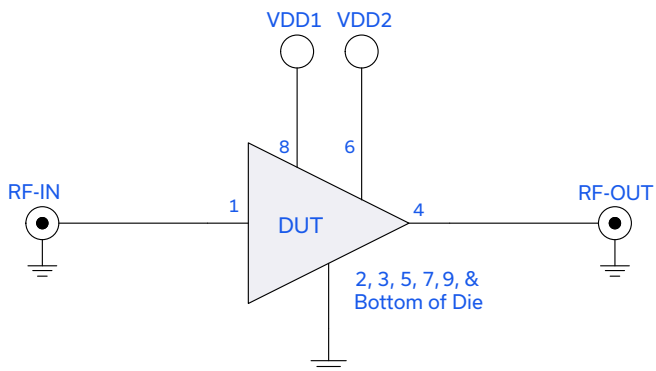

Function	Pad Number	Description
RF-IN	1	RF-Input Pad
RF-OUT	4	RF-Output Pad
VDD1	8	DC Input Pad #1
VDD2	6	DC Input Pad #2
Ground	2, 3, 5, 7, 9, & Bottom of the Die	The bond pads are connected to backside through vias and do not require any wire-bond connections to ground.

BONDING PAD POSITION

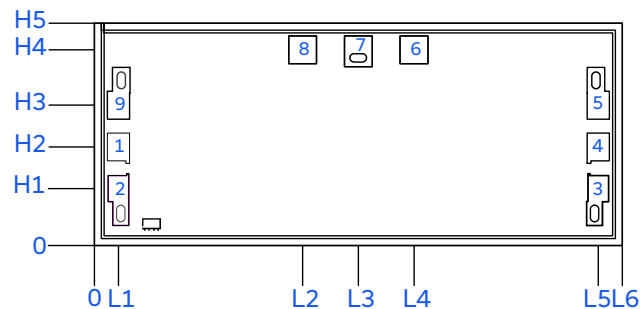

DIMENSIONS IN μM, TYP.

L1	L2	L3	L4	L5	L6
86.0	749.0	949.0	1150.0	1813.0	1900.0
H1	H2	H3	H4	H5	
205.0	355.0	505.0	704.0	800.0	
Thickness	Die Size	Pad Size 1,2,3,4,5 & 9	Pad Size 6 & 8	Pad Size 7	
100	1900 x 800	80 x 100	100 x 100	100 x 110	





MMIC DIE

Wideband Amplifier **AVA-26453LN-D+**

50Ω 26 to 45 GHz

CHARACTERIZATION AND APPLICATION CIRCUIT

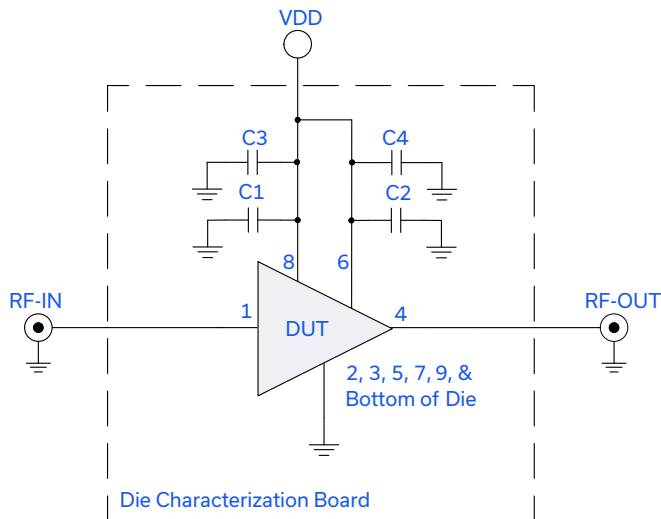

Component	Size	Value	Part Number	Manufacturer
C1, C2	0402	0.1 μF	GRM155R71C104KA88D	Murata
C3, C4	22x22mil	100pF	MA4M3100	Macom

Fig.1 Characterization & Application Circuit

Note: This block diagram is used for characterization (Die is attached and wire-bonded on a die characterization test board). Gain, Return Loss, and Noise Figure are measured using Agilent's N5245B PNA-X Microwave Network Analyzer.

Conditions:

1. VDD = +3V
2. Gain and Return Loss $P_{IN} = -25$ dBm

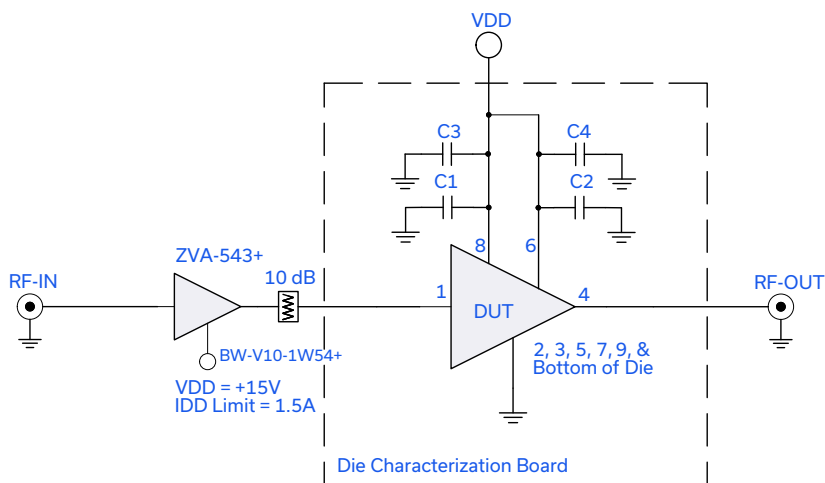

Fig.2 Characterization & Application Circuit with Pre-Amplifier

Note: This block diagram is used for characterization (Die is attached and wire-bonded on a die characterization test board). Gain, Output Power at 1 dB Compression (P_{1dB}), and Output IP3 ($OIP3$) are measured using Agilent's N5245B PNA-X Microwave Network Analyzer.

Conditions:

1. VDD = +3V
2. Gain $P_{IN} = -25$ dBm
3. Output IP3 ($OIP3$): Two Tones, spaced 1 MHz apart, -5 dBm/Tone at Output.



MMIC DIE

Wideband Amplifier **AVA-26453LN-D+**

50Ω 26 to 45 GHz

ASSEMBLY DIAGRAM

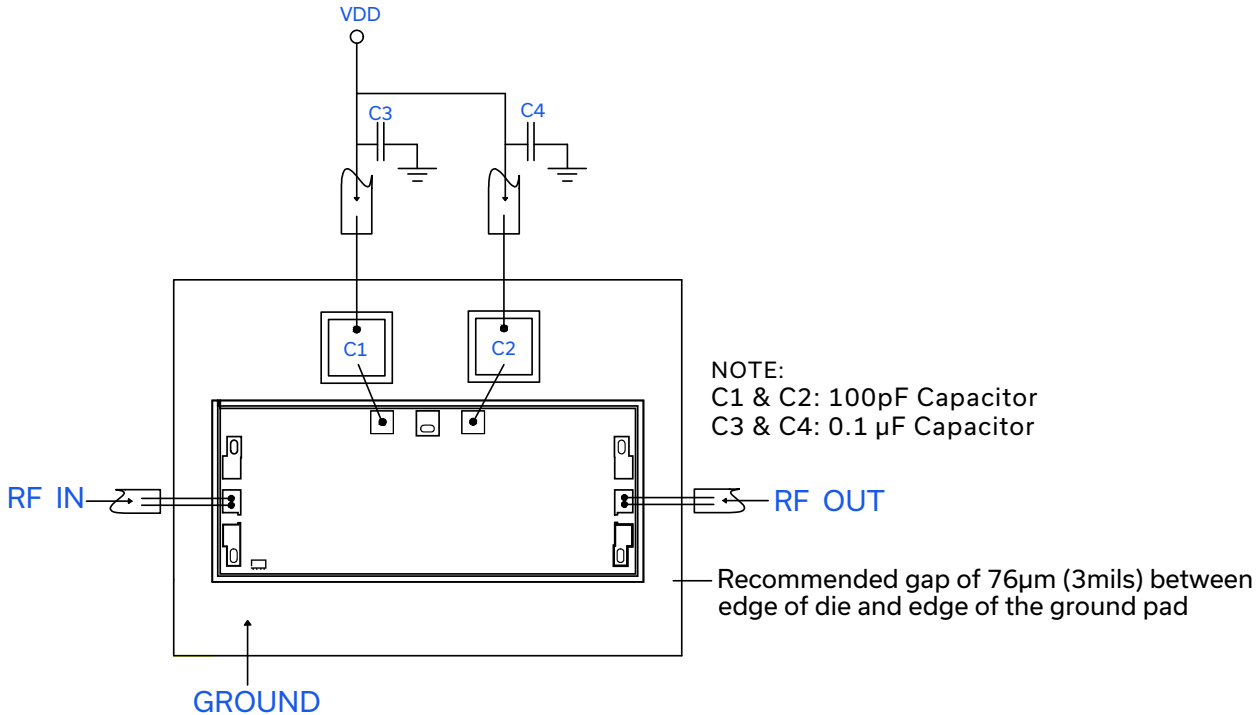

ASSEMBLY PROCEDURE

- Storage**
Die should be stored in a dry nitrogen purged desiccators or equivalent.
- ESD**
 MMIC pHEMT amplifier die are susceptible to electrostatic and mechanical damage. Die are supplied in anti-static protected material, which should be open in clean room conditions at an appropriately grounded anti-static workstation.
- Die Handling and Attachment**
Devices need careful handling using correctly designed collets, it is recommended to handle the chip along the edges with a custom designed collet. The die mounting surface must be clean and flat. Using conductive silver filled epoxy, recommended epoxies are Ablestik 84-1 LMISR4 or equivalents. Apply sufficient epoxy to meet required epoxy bond line thickness, epoxy fillet height and epoxy coverage around total periphery. Parts shall be cured in a nitrogen filled atmosphere per manufacturer's cure condition. The surface of the chip has exposed air bridges and should not be touched with vacuum collet, tweezers or fingers.
- Wire Bonding**
Bond pad openings in the surface passivation above the bond pads are provided to allow wire bonding to the Die gold bond pads. Thermo-sonic bonding is used with minimized ultrasonic content. Bond force, time, ultrasonic power and temperature are all critical parameters. Suggested wire is pure gold, 1mil diameter. Bonds must be made from the bond pads on the die to the packaged or substrate. All bond wire length and bond wire height should be kept as short as possible unless specified by the Assembly Drawing to minimize performance degradation due to undesirable series inductance.



MMIC DIE

Wideband Amplifier **AVA-26453LN-D+**

Mini-Circuits

50Ω 26 to 45 GHz

TYPICAL PERFORMANCE CURVES

GAIN vs. FREQUENCY & TEMPERATURE
@ VDD = +3V

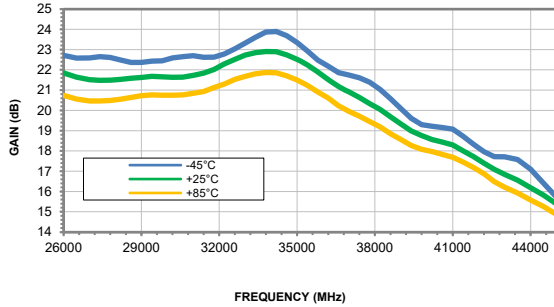

GAIN vs. FREQUENCY & DEVICE VOLTAGE
Temperature = +25°C

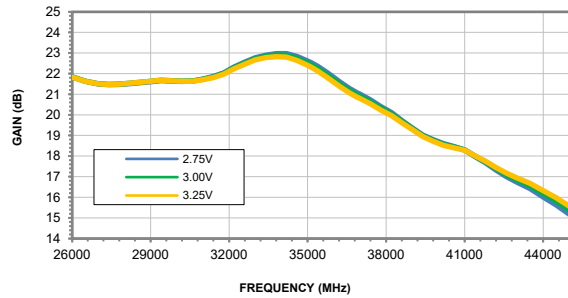

ISOLATION vs. FREQUENCY & TEMPERATURE
@ VDD = +3V

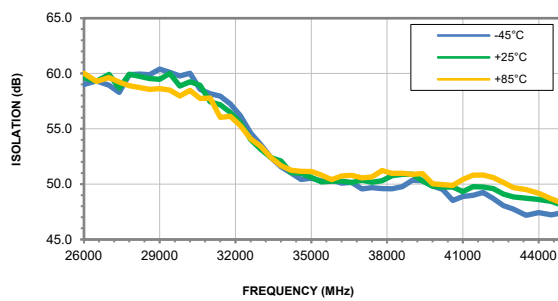

ISOLATION vs. FREQUENCY & DEVICE VOLTAGE
Temperature = +25°C

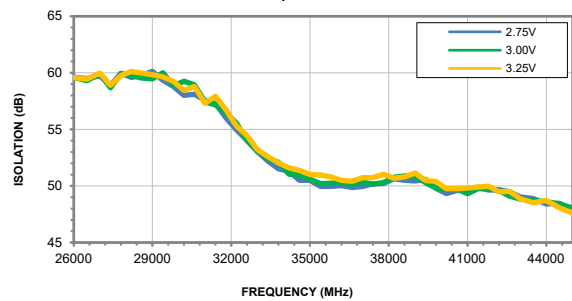

INPUT RETURN LOSS vs. FREQ. & TEMP.
@ VDD = +3V

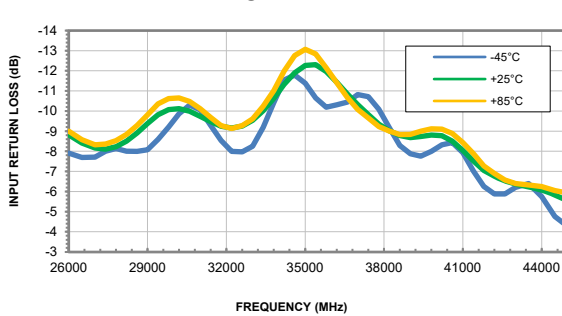

INPUT RETURN LOSS vs. FREQ. & DEVICE VOLTAGE
@ Temperature = +25°C

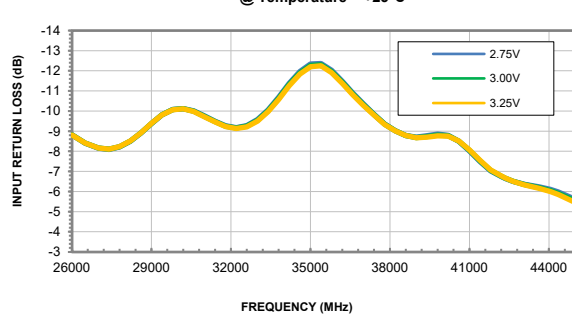

OUTPUT RETURN LOSS vs. FREQ. & TEMP.
@ VDD = +3V

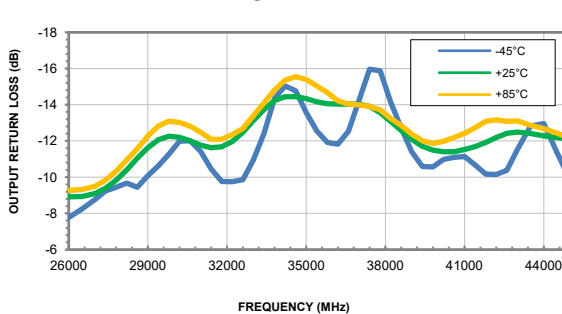

OUTPUT RETURN LOSS vs. FREQ. & DEVICE VOLTAGE
@ Temperature = +25°C

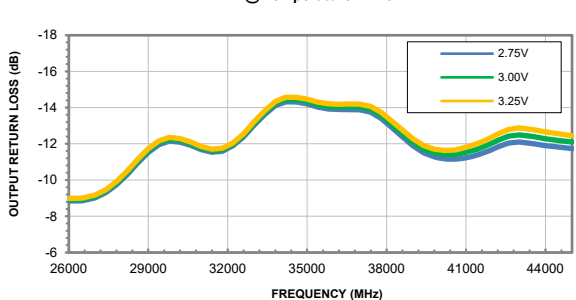



MMIC DIE

Wideband Amplifier **AVA-26453LN-D+**

Mini-Circuits

50Ω 26 to 45 GHz

TYPICAL PERFORMANCE CURVES

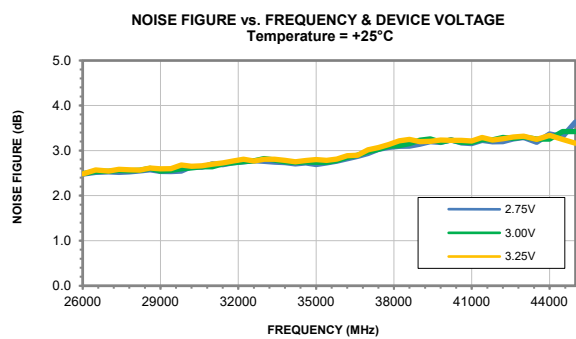
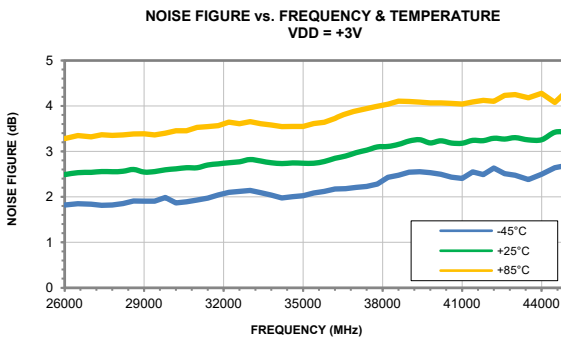
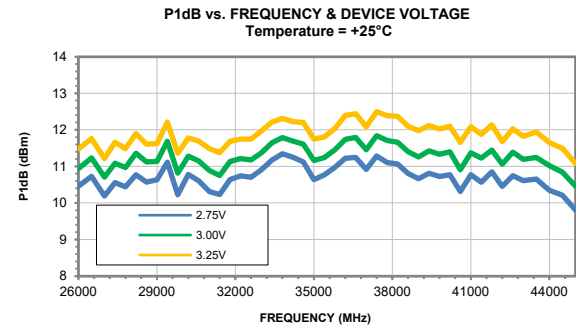
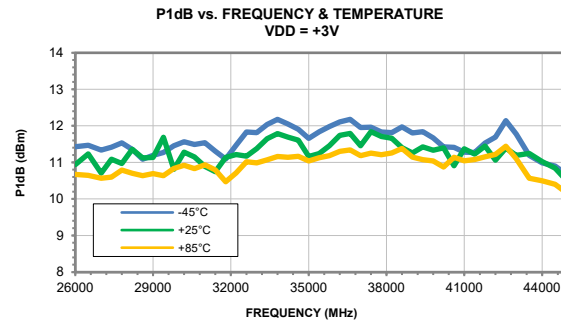
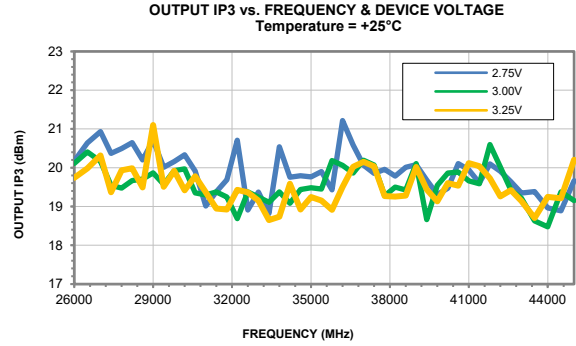
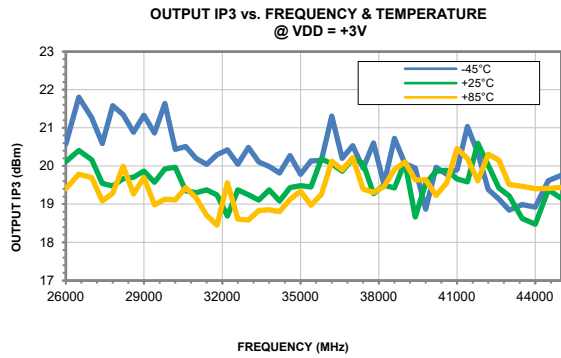



MMIC DIE

Wideband Amplifier **AVA-26453LN-D+**

Mini-Circuits

50Ω 26 to 45 GHz

ADDITIONAL DETAILED TECHNICAL INFORMATION IS AVAILABLE ON OUR DASHBOARD.

Performance Data	Data Table	
	Swept Graphs	
	S-Parameter (S2P Files) Data Set with and without port extension (.zip file)	
Case Style	Die	
Die Ordering and packaging information	Quantity, Package Gel - Pak: 5, 10, 50, 100 Medium [†] , Partial wafer: KGD* < 1100 Full Wafer	Model No. AVA-26453LN-DG+ AVA-26453LN-DP+ AVA-26453LN-DF+
	[†] Available upon request contact sales representative Refer to AN-60-067	
Die Marking	EL-AMP-10-5	
Environmental Ratings	ENV80	

*Known Good Die ('KGD') means that the die in question have been subjected to Mini-Circuits DC test performance criteria and measurement instructions and that the parametric data of such die fall within a predefined range. While DC testing is not definitive, it does provide a higher degree of confidence that die is capable of meeting typical RF electrical performance specified by Mini-Circuits.

NOTES

- A. Performance and quality attributes and conditions not expressly stated in this specification document are intended to be excluded and do not form a part of this specification document.
- B. Electrical specifications and performance data contained in this specification document are based on Mini-Circuit's applicable established test performance criteria and measurement instructions.
- C. The parts covered by this specification document are subject to Mini-Circuits standard limited warranty and terms and conditions (collectively, "Standard Terms"); Purchasers of this part are entitled to the rights and benefits contained therein. For a full statement of the standard. Terms and the exclusive rights and remedies thereunder, please visit Mini-Circuits' website at www.minicircuits.com/terms/viewterm.html
- D. Mini-Circuits does not warrant the accuracy or completeness of the information, text, graphics and other items contained within this document and are provided as an accommodation and on an as is basis, with all faults.
- E. Purchasers of this part are solely responsible for proper storing, handling, assembly, and processing of Known Good Die (including, without limitation, proper ESD preventative measures, die preparation, die attach, wire bonding and related assembly and test activities), and Mini-Circuits assumes no responsibility therefor or for environmental effects on Known Good Die.
- F. Mini-Circuits and the Mini-Circuits logo are registered trademarks of Scientific Components Corporation d/b/a Mini-Circuits. All other third-party trademarks are the property of their respective owners. A reference to any third-party trademark does not constitute or imply any endorsement, affiliation, sponsorship, or recommendation by any such third-party of Mini-Circuits or its products.



Typical Performance Data

Definitions:

Input Return Loss = -S11 (dB)

Gain(Power Gain) = S21 (dB)

Reverse Isolation = -S12 (dB)

Output Return Loss = -S22 (dB)

TEST CONDITIONS: VDD= +2.75V, IDD = 82mA @ Temperature = +25°C

FREQ	Gain	Isolation	Input Return Loss	Output Return Loss	Stability		IP-3 Output	1dB Comp. Output	Noise Figure
					K	Measure			
(MHz)	(dB)	(dB)	(dB)	(dB)	K	Measure	(dBm)	(dBm)	(dB)
26000.00	21.84	59.61	-8.82	-8.85	39.50	0.99	20.17	10.46	2.48
26500.00	21.63	59.49	-8.40	-8.85	39.52	1.00	20.64	10.73	2.52
27000.00	21.50	59.73	-8.15	-9.02	41.23	1.01	20.93	10.19	2.53
27400.00	21.46	58.89	-8.09	-9.31	37.92	1.02	20.37	10.55	2.51
27800.00	21.47	59.95	-8.22	-9.74	43.75	1.03	20.49	10.44	2.53
28200.00	21.51	59.60	-8.49	-10.29	43.07	1.04	20.65	10.77	2.55
28600.00	21.56	59.78	-8.90	-10.93	44.98	1.04	20.20	10.57	2.57
29000.00	21.61	60.14	-9.37	-11.51	48.09	1.04	20.71	10.63	2.54
29400.00	21.66	59.34	-9.81	-11.95	44.61	1.03	20.01	11.11	2.53
29800.00	21.63	58.78	-10.08	-12.15	42.55	1.03	20.16	10.22	2.54
30200.00	21.62	58.00	-10.12	-12.09	39.03	1.03	20.33	10.78	2.64
30600.00	21.63	58.10	-10.00	-11.91	39.34	1.03	19.91	10.60	2.63
31000.00	21.73	57.55	-9.76	-11.68	36.28	1.03	19.01	10.31	2.71
31400.00	21.86	57.30	-9.49	-11.53	34.44	1.03	19.38	10.23	2.69
31800.00	22.04	56.01	-9.26	-11.59	29.06	1.04	19.69	10.64	2.73
32200.00	22.33	54.96	-9.17	-11.89	25.10	1.05	20.71	10.74	2.75
32600.00	22.56	54.03	-9.27	-12.38	22.23	1.05	18.91	10.70	2.77
33000.00	22.77	53.02	-9.58	-13.03	19.78	1.05	19.37	10.91	2.76
33400.00	22.89	52.20	-10.06	-13.62	18.10	1.05	18.82	11.17	2.74
33800.00	22.97	51.51	-10.68	-14.11	16.91	1.04	20.54	11.34	2.73
34200.00	22.97	51.29	-11.37	-14.32	16.83	1.03	19.76	11.25	2.70
34600.00	22.83	50.51	-11.96	-14.31	15.78	1.02	19.79	11.12	2.73
35000.00	22.61	50.50	-12.34	-14.20	16.33	1.02	19.76	10.63	2.69
35400.00	22.34	49.96	-12.37	-14.02	15.88	1.01	19.90	10.77	2.72
35800.00	22.00	49.96	-12.03	-13.92	16.48	1.02	19.43	10.97	2.77
36200.00	21.62	50.03	-11.48	-13.90	17.20	1.03	21.22	11.22	2.82
36600.00	21.28	49.86	-10.89	-13.89	17.37	1.04	20.58	11.24	2.87
37000.00	21.01	49.94	-10.36	-13.88	17.93	1.05	20.07	10.92	2.93
37400.00	20.73	50.18	-9.84	-13.74	18.76	1.06	19.85	11.28	3.03
37800.00	20.40	50.22	-9.36	-13.39	19.20	1.07	19.96	11.11	3.07
38200.00	20.11	50.65	-9.02	-12.89	20.66	1.07	19.78	11.06	3.09
38600.00	19.73	50.51	-8.78	-12.38	20.99	1.07	20.01	10.81	3.10
39000.00	19.36	50.45	-8.70	-11.89	21.67	1.06	20.08	10.66	3.14
39400.00	19.02	50.58	-8.77	-11.50	22.90	1.05	19.68	10.81	3.20
39800.00	18.80	49.78	-8.85	-11.28	21.55	1.05	19.31	10.72	3.18
40200.00	18.60	49.33	-8.79	-11.17	20.87	1.05	19.47	10.77	3.24
40600.00	18.46	49.61	-8.49	-11.15	21.73	1.05	20.11	10.31	3.17
41000.00	18.30	49.55	-8.01	-11.24	21.69	1.07	19.94	10.77	3.15
41400.00	17.97	49.89	-7.48	-11.37	22.80	1.09	19.60	10.56	3.23
41800.00	17.67	49.63	-7.02	-11.58	22.57	1.11	20.10	10.85	3.19
42200.00	17.32	49.67	-6.74	-11.82	23.37	1.13	19.91	10.45	3.20
42600.00	17.00	49.49	-6.53	-12.04	23.61	1.14	19.64	10.74	3.26
43000.00	16.73	49.04	-6.37	-12.10	23.07	1.15	19.35	10.61	3.29
43500.00	16.41	48.89	-6.26	-12.01	23.47	1.15	19.38	10.65	3.18
44000.00	16.02	48.41	-6.12	-11.90	22.93	1.16	18.96	10.35	3.37
44500.00	15.62	48.46	-5.89	-11.81	23.79	1.17	18.89	10.21	3.31
45000.00	15.18	47.90	-5.62	-11.74	23.02	1.19	19.66	9.80	3.64

Typical Performance Data

Definitions:

Input Return Loss = -S11 (dB)

Gain(Power Gain) = S21 (dB)

Reverse Isolation = -S12 (dB)

Output Return Loss = -S22 (dB)

TEST CONDITIONS: VDD = +3V, IDD = 83mA @ Temperature = +25°C

FREQ	Gain	Isolation	Input Return Loss	Output Return Loss	Stability		IP-3 Output	1dB Comp. Output	Noise Figure
					K	Measure			
(MHz)	(dB)	(dB)	(dB)	(dB)	K	Measure	(dBm)	(dBm)	(dB)
26000.00	21.85	59.61	-8.81	-8.92	39.56	0.99	20.11	10.94	2.49
26500.00	21.64	59.29	-8.41	-8.93	38.66	1.00	20.41	11.23	2.53
27000.00	21.51	59.91	-8.16	-9.10	42.18	1.01	20.16	10.70	2.54
27400.00	21.48	58.67	-8.10	-9.39	37.00	1.02	19.54	11.09	2.56
27800.00	21.49	59.93	-8.23	-9.83	43.68	1.03	19.47	10.97	2.55
28200.00	21.53	59.74	-8.51	-10.39	43.81	1.04	19.67	11.36	2.56
28600.00	21.58	59.54	-8.91	-11.04	43.79	1.04	19.71	11.12	2.60
29000.00	21.63	59.46	-9.38	-11.62	44.45	1.04	19.87	11.13	2.55
29400.00	21.68	60.01	-9.81	-12.06	48.16	1.04	19.57	11.69	2.56
29800.00	21.65	58.86	-10.07	-12.26	42.90	1.03	19.93	10.81	2.60
30200.00	21.63	59.25	-10.12	-12.19	45.04	1.03	19.97	11.28	2.62
30600.00	21.64	58.93	-9.99	-12.01	43.30	1.03	19.35	11.15	2.64
31000.00	21.73	57.43	-9.74	-11.77	35.83	1.03	19.30	10.89	2.64
31400.00	21.84	57.17	-9.48	-11.62	34.05	1.04	19.37	10.75	2.70
31800.00	22.02	56.47	-9.25	-11.67	30.77	1.04	19.24	11.14	2.73
32200.00	22.29	55.55	-9.15	-11.97	27.01	1.05	18.69	11.21	2.75
32600.00	22.52	54.01	-9.25	-12.47	22.29	1.05	19.38	11.17	2.77
33000.00	22.73	53.14	-9.54	-13.13	20.15	1.05	19.24	11.37	2.82
33400.00	22.84	52.40	-10.01	-13.73	18.64	1.05	19.11	11.65	2.79
33800.00	22.91	52.10	-10.63	-14.23	18.21	1.04	19.37	11.79	2.75
34200.00	22.89	51.03	-11.32	-14.45	16.48	1.03	19.08	11.69	2.73
34600.00	22.74	50.99	-11.90	-14.44	16.85	1.02	19.43	11.61	2.75
35000.00	22.52	50.61	-12.26	-14.33	16.71	1.02	19.48	11.16	2.74
35400.00	22.23	50.20	-12.31	-14.16	16.52	1.02	19.45	11.24	2.74
35800.00	21.89	50.25	-11.96	-14.06	17.26	1.02	20.19	11.45	2.78
36200.00	21.52	50.26	-11.43	-14.04	17.88	1.03	20.06	11.74	2.85
36600.00	21.18	50.14	-10.85	-14.04	18.16	1.04	19.86	11.79	2.90
37000.00	20.91	50.34	-10.32	-14.03	19.00	1.05	20.19	11.45	2.97
37400.00	20.64	50.16	-9.82	-13.91	18.94	1.06	20.07	11.84	3.03
37800.00	20.33	50.30	-9.35	-13.56	19.59	1.07	19.27	11.71	3.10
38200.00	20.05	50.77	-9.02	-13.07	21.15	1.07	19.50	11.66	3.11
38600.00	19.68	50.88	-8.78	-12.57	22.10	1.07	19.42	11.40	3.15
39000.00	19.33	50.90	-8.68	-12.08	22.96	1.07	20.11	11.26	3.23
39400.00	18.99	50.28	-8.73	-11.70	22.24	1.06	18.66	11.42	3.26
39800.00	18.76	49.81	-8.80	-11.49	21.78	1.05	19.54	11.33	3.19
40200.00	18.56	49.73	-8.77	-11.40	22.01	1.05	19.86	11.40	3.23
40600.00	18.43	49.74	-8.51	-11.40	22.23	1.06	19.89	10.90	3.19
41000.00	18.29	49.32	-8.04	-11.53	21.26	1.08	19.66	11.37	3.18
41400.00	18.00	49.77	-7.52	-11.68	22.57	1.10	19.58	11.23	3.24
41800.00	17.72	49.73	-7.05	-11.92	22.85	1.12	20.60	11.44	3.24
42200.00	17.39	49.59	-6.76	-12.19	23.11	1.14	20.02	11.06	3.29
42600.00	17.09	49.10	-6.54	-12.42	22.46	1.15	19.43	11.39	3.27
43000.00	16.84	48.84	-6.37	-12.49	22.38	1.16	19.21	11.19	3.30
43500.00	16.56	48.73	-6.23	-12.41	22.75	1.16	18.63	11.25	3.25
44000.00	16.19	48.61	-6.07	-12.28	23.07	1.17	18.48	11.02	3.26
44500.00	15.81	48.43	-5.82	-12.18	23.20	1.18	19.38	10.84	3.42
45000.00	15.39	48.04	-5.54	-12.10	22.82	1.20	19.15	10.46	3.42

Typical Performance Data

Definitions:

Input Return Loss = -S11 (dB)

Gain(Power Gain) = S21 (dB)

Reverse Isolation = -S12 (dB)

Output Return Loss = -S22 (dB)

TEST CONDITIONS: VDD = +3.25V, IDD = 84mA @ Temperature = +25°C

FREQ	Gain	Isolation	Input Return Loss	Output Return Loss	Stability		IP-3 Output	1dB Comp. Output	Noise Figure
					K	Measure			
(MHz)	(dB)	(dB)	(dB)	(dB)	K	Measure	(dBm)	(dBm)	(dB)
26000.00	21.83	59.57	-8.81	-8.99	39.57	0.99	19.74	11.48	2.48
26500.00	21.63	59.43	-8.40	-9.00	39.45	1.00	19.98	11.76	2.57
27000.00	21.50	59.97	-8.16	-9.17	42.58	1.02	20.31	11.21	2.55
27400.00	21.48	58.90	-8.11	-9.47	38.08	1.03	19.37	11.66	2.58
27800.00	21.49	59.76	-8.23	-9.92	42.92	1.03	19.93	11.49	2.57
28200.00	21.53	60.13	-8.51	-10.49	45.90	1.04	19.99	11.90	2.56
28600.00	21.58	59.97	-8.91	-11.14	46.11	1.04	19.49	11.61	2.61
29000.00	21.63	59.83	-9.38	-11.73	46.50	1.04	21.10	11.62	2.60
29400.00	21.68	59.64	-9.81	-12.16	46.25	1.04	19.51	12.21	2.60
29800.00	21.65	59.24	-10.07	-12.36	44.89	1.04	19.92	11.36	2.68
30200.00	21.63	58.45	-10.11	-12.29	41.13	1.03	19.41	11.78	2.65
30600.00	21.63	58.80	-9.97	-12.10	42.76	1.03	19.78	11.69	2.66
31000.00	21.70	57.30	-9.72	-11.85	35.41	1.03	19.37	11.48	2.70
31400.00	21.80	57.92	-9.45	-11.71	37.33	1.04	18.95	11.38	2.73
31800.00	21.97	56.74	-9.22	-11.75	31.90	1.04	18.92	11.69	2.77
32200.00	22.24	55.30	-9.13	-12.05	26.40	1.05	19.43	11.75	2.81
32600.00	22.46	54.46	-9.21	-12.55	23.62	1.06	19.36	11.74	2.77
33000.00	22.67	53.20	-9.50	-13.23	20.41	1.06	19.15	11.98	2.81
33400.00	22.78	52.57	-9.96	-13.83	19.16	1.05	18.65	12.21	2.81
33800.00	22.82	52.03	-10.57	-14.34	18.25	1.04	18.74	12.31	2.78
34200.00	22.80	51.60	-11.26	-14.58	17.78	1.03	19.59	12.22	2.75
34600.00	22.63	51.38	-11.83	-14.56	17.85	1.03	18.92	12.20	2.78
35000.00	22.40	51.01	-12.20	-14.47	17.74	1.02	19.24	11.75	2.80
35400.00	22.11	50.97	-12.25	-14.30	18.33	1.02	19.15	11.80	2.78
35800.00	21.77	50.80	-11.91	-14.21	18.65	1.02	18.91	12.03	2.81
36200.00	21.40	50.50	-11.37	-14.18	18.64	1.03	19.50	12.39	2.88
36600.00	21.06	50.41	-10.80	-14.20	19.00	1.04	20.02	12.44	2.89
37000.00	20.80	50.73	-10.28	-14.18	20.14	1.05	20.15	12.08	3.02
37400.00	20.53	50.74	-9.80	-14.07	20.50	1.06	20.03	12.50	3.07
37800.00	20.23	51.03	-9.33	-13.74	21.57	1.07	19.27	12.39	3.13
38200.00	19.96	50.68	-9.02	-13.24	21.19	1.07	19.26	12.37	3.22
38600.00	19.62	50.80	-8.78	-12.76	22.11	1.08	19.28	12.10	3.25
39000.00	19.28	51.14	-8.67	-12.28	23.81	1.07	20.02	11.97	3.20
39400.00	18.95	50.49	-8.70	-11.90	22.95	1.06	19.44	12.12	3.21
39800.00	18.72	50.40	-8.77	-11.70	23.49	1.06	19.13	12.02	3.23
40200.00	18.52	49.76	-8.75	-11.63	22.27	1.06	19.60	12.10	3.23
40600.00	18.40	49.77	-8.51	-11.66	22.49	1.06	19.54	11.65	3.23
41000.00	18.28	49.82	-8.07	-11.81	22.69	1.08	20.12	12.08	3.21
41400.00	18.01	49.91	-7.55	-12.00	23.07	1.10	20.04	11.88	3.29
41800.00	17.75	49.98	-7.07	-12.24	23.57	1.12	19.72	12.14	3.23
42200.00	17.44	49.48	-6.77	-12.54	22.82	1.14	19.26	11.68	3.26
42600.00	17.17	49.52	-6.54	-12.79	23.48	1.15	19.42	12.03	3.30
43000.00	16.94	48.87	-6.35	-12.88	22.28	1.16	19.14	11.82	3.32
43500.00	16.68	48.51	-6.20	-12.79	21.96	1.17	18.70	11.94	3.25
44000.00	16.33	48.73	-6.02	-12.65	23.03	1.18	19.25	11.65	3.34
44500.00	15.98	48.07	-5.76	-12.55	21.85	1.19	19.21	11.49	3.25
45000.00	15.56	47.62	-5.46	-12.45	21.26	1.21	20.20	11.08	3.16

Typical Performance Data

Definitions:

Input Return Loss = -S11 (dB)

Gain(Power Gain) = S21 (dB)

Reverse Isolation = -S12 (dB)

Output Return Loss = -S22 (dB)

TEST CONDITIONS: VDD = +2.75V, IDD =80mA @ Temperature = -45°C

FREQ	Gain	Isolation	Input Return Loss	Output Return Loss	Stability		IP-3 Output	1dB Comp. Output	Noise Figure
					K	Measure			
(MHz)	(dB)	(dB)	(dB)	(dB)	K	Measure	(dBm)	(dBm)	(dB)
26000.00	22.74	59.59	-7.95	-7.71	31.35	0.97	20.95	10.88	1.79
26500.00	22.60	59.17	-7.72	-8.16	30.79	0.99	21.56	10.94	1.84
27000.00	22.61	58.40	-7.73	-8.69	28.90	1.01	21.30	10.78	1.82
27400.00	22.67	58.26	-8.02	-9.15	29.11	1.02	21.15	10.86	1.82
27800.00	22.62	59.04	-8.16	-9.36	32.53	1.02	20.88	10.95	1.78
28200.00	22.50	59.46	-8.02	-9.59	34.77	1.03	21.05	10.80	1.83
28600.00	22.38	59.60	-8.00	-9.36	35.54	1.03	21.29	10.55	1.91
29000.00	22.38	58.94	-8.09	-9.99	33.77	1.04	22.15	10.68	1.86
29400.00	22.43	59.66	-8.60	-10.53	37.74	1.04	21.56	10.81	1.88
29800.00	22.45	59.35	-9.22	-11.17	37.73	1.03	21.35	10.91	1.88
30200.00	22.59	58.81	-9.88	-11.88	36.16	1.03	21.34	11.00	1.89
30600.00	22.66	59.37	-10.33	-11.91	38.83	1.02	21.27	10.96	1.87
31000.00	22.71	58.39	-10.11	-11.33	34.04	1.02	21.28	11.00	1.92
31400.00	22.65	57.93	-9.32	-10.37	31.29	1.02	20.48	10.74	1.93
31800.00	22.66	57.02	-8.56	-9.69	27.14	1.02	19.92	10.53	1.99
32200.00	22.83	55.80	-8.02	-9.69	22.70	1.03	20.59	10.92	2.06
32600.00	23.09	54.40	-8.00	-9.80	18.84	1.03	20.47	11.30	2.08
33000.00	23.38	53.28	-8.29	-10.89	16.70	1.05	20.15	11.33	2.12
33400.00	23.65	52.16	-9.23	-12.34	15.06	1.05	21.56	11.53	2.07
33800.00	23.93	51.32	-10.47	-14.25	14.01	1.04	20.12	11.62	2.00
34200.00	23.97	50.69	-11.60	-14.92	13.36	1.03	20.36	11.52	1.96
34600.00	23.79	50.31	-11.86	-14.69	13.11	1.02	20.67	11.37	1.96
35000.00	23.45	50.50	-11.45	-13.49	13.73	1.02	19.93	11.11	2.01
35400.00	23.05	50.34	-10.71	-12.47	13.78	1.02	20.40	11.29	2.06
35800.00	22.61	50.19	-10.24	-11.83	14.02	1.02	21.22	11.47	2.11
36200.00	22.31	49.94	-10.37	-11.72	14.13	1.02	21.81	11.61	2.14
36600.00	22.00	49.67	-10.51	-12.41	14.42	1.03	22.76	11.63	2.12
37000.00	21.88	49.29	-10.88	-14.07	14.41	1.04	21.38	11.40	2.17
37400.00	21.74	49.52	-10.77	-15.76	15.17	1.06	21.27	11.37	2.19
37800.00	21.51	49.18	-10.15	-15.67	14.78	1.07	21.59	11.24	2.25
38200.00	21.15	49.22	-9.22	-13.99	14.86	1.08	20.93	11.24	2.37
38600.00	20.68	49.65	-8.33	-12.56	15.76	1.09	21.85	11.31	2.47
39000.00	20.17	50.09	-7.91	-11.24	16.96	1.08	21.27	11.19	2.51
39400.00	19.69	49.70	-7.82	-10.44	16.85	1.06	20.71	11.20	2.50
39800.00	19.38	49.60	-8.10	-10.40	17.53	1.05	20.16	11.00	2.50
40200.00	19.32	48.64	-8.43	-10.81	16.28	1.05	19.92	10.76	2.49
40600.00	19.26	48.64	-8.51	-10.89	16.58	1.05	20.90	10.72	2.41
41000.00	19.17	48.83	-7.97	-10.90	16.86	1.07	21.18	10.54	2.39
41400.00	18.79	48.75	-7.04	-10.42	16.40	1.09	21.30	10.59	2.49
41800.00	18.37	48.91	-6.26	-9.92	16.52	1.11	21.28	10.80	2.47
42200.00	17.98	48.82	-5.89	-9.88	16.67	1.12	21.26	10.94	2.53
42600.00	17.72	48.07	-5.90	-10.11	16.00	1.13	20.62	11.38	2.46
43000.00	17.70	47.67	-6.23	-11.21	16.21	1.14	20.88	11.02	2.45
43500.00	17.55	47.25	-6.45	-12.45	16.31	1.15	20.27	10.42	2.35
44000.00	17.06	47.29	-5.81	-12.56	16.48	1.19	20.11	10.19	2.45
44500.00	16.34	47.47	-4.82	-11.04	16.27	1.22	21.46	10.16	2.63
45000.00	15.63	47.66	-4.33	-9.57	16.51	1.21	20.27	9.91	2.56

Typical Performance Data

Definitions:

Input Return Loss = -S11 (dB)

Gain(Power Gain) = S21 (dB)

Reverse Isolation = -S12 (dB)

Output Return Loss = -S22 (dB)

TEST CONDITIONS: VDD = +3V, IDD = 81mA @ Temperature = -45°C

FREQ	Gain	Isolation	Input Return Loss	Output Return Loss	Stability		IP-3 Output	1dB Comp. Output	Noise Figure
					K	Measure			
(MHz)	(dB)	(dB)	(dB)	(dB)	K	Measure	(dBm)	(dBm)	(dB)
26000.00	22.71	59.01	-7.90	-7.78	29.43	0.97	20.57	11.43	1.82
26500.00	22.58	59.33	-7.69	-8.24	31.46	1.00	21.80	11.47	1.85
27000.00	22.59	58.93	-7.71	-8.77	30.86	1.02	21.26	11.33	1.84
27400.00	22.65	58.28	-8.00	-9.24	29.32	1.02	20.59	11.42	1.82
27800.00	22.61	59.88	-8.14	-9.44	35.98	1.02	21.58	11.53	1.82
28200.00	22.48	59.94	-8.00	-9.67	36.86	1.04	21.34	11.35	1.85
28600.00	22.37	59.89	-7.99	-9.45	36.85	1.03	20.88	11.09	1.91
29000.00	22.37	60.39	-8.07	-10.08	40.02	1.04	21.33	11.19	1.90
29400.00	22.43	60.10	-8.59	-10.62	39.84	1.04	20.86	11.27	1.91
29800.00	22.45	59.77	-9.20	-11.27	39.68	1.04	21.64	11.45	1.98
30200.00	22.58	60.02	-9.86	-11.99	41.61	1.03	20.43	11.56	1.86
30600.00	22.65	58.56	-10.29	-12.01	35.40	1.03	20.51	11.49	1.89
31000.00	22.70	58.17	-10.06	-11.42	33.25	1.02	20.20	11.54	1.93
31400.00	22.62	57.94	-9.28	-10.45	31.45	1.02	20.04	11.31	1.97
31800.00	22.63	57.24	-8.53	-9.76	27.95	1.02	20.30	11.09	2.04
32200.00	22.78	56.17	-7.99	-9.75	23.83	1.04	20.42	11.47	2.10
32600.00	23.04	54.61	-7.97	-9.86	19.44	1.04	20.05	11.83	2.12
33000.00	23.32	53.57	-8.25	-10.95	17.36	1.05	20.48	11.81	2.14
33400.00	23.60	52.41	-9.19	-12.41	15.60	1.05	20.10	12.04	2.09
33800.00	23.87	51.57	-10.41	-14.34	14.52	1.05	19.99	12.18	2.04
34200.00	23.89	51.01	-11.54	-15.04	13.98	1.03	19.81	12.05	1.98
34600.00	23.69	50.42	-11.79	-14.77	13.43	1.03	20.27	11.91	2.00
35000.00	23.34	50.54	-11.38	-13.57	13.95	1.02	19.78	11.66	2.02
35400.00	22.93	50.28	-10.65	-12.55	13.89	1.02	20.14	11.83	2.08
35800.00	22.48	50.37	-10.19	-11.91	14.52	1.02	20.14	11.98	2.12
36200.00	22.18	50.09	-10.31	-11.82	14.60	1.02	21.31	12.11	2.17
36600.00	21.86	50.15	-10.45	-12.53	15.48	1.03	20.20	12.17	2.18
37000.00	21.75	49.56	-10.82	-14.24	15.10	1.04	20.53	11.95	2.21
37400.00	21.61	49.67	-10.71	-15.97	15.67	1.06	19.94	11.96	2.23
37800.00	21.38	49.59	-10.09	-15.87	15.72	1.07	20.60	11.83	2.28
38200.00	21.04	49.58	-9.18	-14.15	15.72	1.08	19.53	11.81	2.43
38600.00	20.57	49.76	-8.29	-12.70	16.17	1.09	20.72	11.97	2.47
39000.00	20.08	50.35	-7.88	-11.39	17.68	1.08	20.06	11.80	2.54
39400.00	19.61	50.30	-7.76	-10.59	18.23	1.07	19.95	11.84	2.55
39800.00	19.30	49.82	-8.00	-10.56	18.13	1.06	18.87	11.67	2.53
40200.00	19.22	49.52	-8.32	-10.98	18.22	1.06	19.97	11.42	2.49
40600.00	19.15	48.53	-8.43	-11.10	16.58	1.06	19.78	11.41	2.43
41000.00	19.08	48.88	-7.93	-11.14	17.18	1.07	19.90	11.28	2.40
41400.00	18.72	48.99	-7.02	-10.67	17.06	1.10	21.03	11.27	2.55
41800.00	18.33	49.24	-6.25	-10.17	17.35	1.12	20.34	11.53	2.49
42200.00	17.96	48.69	-5.88	-10.15	16.56	1.13	19.38	11.69	2.63
42600.00	17.72	48.05	-5.88	-10.38	16.05	1.14	19.14	12.14	2.51
43000.00	17.71	47.74	-6.21	-11.52	16.38	1.15	18.85	11.78	2.48
43500.00	17.58	47.19	-6.39	-12.83	16.15	1.16	18.99	11.19	2.38
44000.00	17.10	47.42	-5.75	-12.96	16.64	1.20	18.92	10.99	2.50
44500.00	16.40	47.22	-4.76	-11.37	15.67	1.23	19.61	10.90	2.64
45000.00	15.71	47.44	-4.26	-9.83	15.92	1.22	19.76	10.65	2.70

Typical Performance Data

Definitions:

Input Return Loss = -S11 (dB)

Gain(Power Gain) = S21 (dB)

Reverse Isolation = -S12 (dB)

Output Return Loss = -S22 (dB)

TEST CONDITIONS: VDD = +3.25V, IDD = 82mA @ Temperature = -45°C

FREQ	Gain	Isolation	Input Return Loss	Output Return Loss	Stability		IP-3 Output	1dB Comp. Output	Noise Figure
					K	Measure			
(MHz)	(dB)	(dB)	(dB)	(dB)	K	Measure	(dBm)	(dBm)	(dB)
26000.00	22.68	59.46	-7.88	-7.84	31.19	0.98	20.50	11.90	1.81
26500.00	22.56	59.28	-7.67	-8.31	31.44	1.00	21.22	11.90	1.89
27000.00	22.57	59.26	-7.69	-8.85	32.19	1.02	20.77	11.78	1.85
27400.00	22.63	58.48	-8.00	-9.32	30.13	1.03	20.21	11.90	1.84
27800.00	22.59	59.62	-8.13	-9.52	35.05	1.03	21.06	11.98	1.86
28200.00	22.47	59.52	-8.00	-9.75	35.22	1.04	21.20	11.77	1.89
28600.00	22.35	60.45	-7.99	-9.53	39.48	1.03	20.53	11.58	1.93
29000.00	22.36	59.60	-8.07	-10.17	36.67	1.05	21.05	11.64	1.90
29400.00	22.41	58.89	-8.58	-10.71	34.76	1.04	20.85	11.67	1.91
29800.00	22.44	59.31	-9.19	-11.37	37.68	1.04	20.64	11.89	1.93
30200.00	22.58	59.70	-9.85	-12.09	40.19	1.04	20.08	12.08	1.91
30600.00	22.64	58.68	-10.27	-12.10	35.95	1.03	20.77	11.96	1.93
31000.00	22.68	58.98	-10.04	-11.51	36.65	1.02	20.00	12.02	1.95
31400.00	22.59	58.94	-9.26	-10.52	35.46	1.02	20.13	11.81	2.01
31800.00	22.59	57.93	-8.50	-9.82	30.45	1.02	19.76	11.57	2.06
32200.00	22.73	56.36	-7.97	-9.81	24.52	1.04	19.55	11.92	2.12
32600.00	22.98	54.89	-7.94	-9.92	20.20	1.04	20.01	12.26	2.15
33000.00	23.27	53.82	-8.22	-11.02	17.99	1.06	19.74	12.24	2.19
33400.00	23.54	52.45	-9.14	-12.49	15.76	1.05	20.19	12.43	2.15
33800.00	23.79	51.64	-10.36	-14.45	14.77	1.05	19.31	12.60	2.07
34200.00	23.80	51.11	-11.48	-15.13	14.30	1.03	20.22	12.48	2.01
34600.00	23.58	50.81	-11.72	-14.87	14.22	1.03	19.31	12.36	2.03
35000.00	23.22	50.82	11.32	-13.66	14.60	1.02	19.24	12.13	2.06
35400.00	22.80	50.61	-10.59	-12.64	14.63	1.03	19.91	12.30	2.12
35800.00	22.35	50.51	-10.14	-12.01	14.98	1.03	19.75	12.40	2.14
36200.00	22.04	50.44	10.26	-11.93	15.43	1.02	20.49	12.53	2.20
36600.00	21.74	50.42	-10.39	-12.67	16.21	1.03	20.40	12.61	2.19
37000.00	21.62	49.69	-10.77	-14.41	15.54	1.05	20.25	12.47	2.21
37400.00	21.49	49.89	-10.66	-16.19	16.30	1.06	20.01	12.45	2.24
37800.00	21.27	49.74	-10.05	-16.06	16.21	1.07	20.08	12.34	2.31
38200.00	20.93	49.69	-9.15	-14.30	16.12	1.08	19.87	12.34	2.42
38600.00	20.48	50.13	-8.27	-12.85	17.07	1.09	20.06	12.51	2.51
39000.00	20.01	50.50	-7.85	-11.54	18.19	1.09	20.32	12.34	2.57
39400.00	19.55	50.57	-7.72	-10.76	18.97	1.07	20.28	12.37	2.56
39800.00	19.25	50.17	-7.93	-10.74	19.01	1.07	19.48	12.21	2.54
40200.00	19.15	49.37	-8.25	-11.18	18.06	1.06	19.88	11.97	2.58
40600.00	19.08	49.03	-8.38	-11.31	17.76	1.06	19.44	12.03	2.46
41000.00	19.01	48.56	-7.91	-11.39	16.75	1.08	20.13	11.87	2.44
41400.00	18.68	49.06	-7.02	-10.92	17.38	1.10	19.86	11.84	2.55
41800.00	18.30	49.34	-6.26	-10.43	17.70	1.12	20.82	12.08	2.54
42200.00	17.96	48.50	-5.88	-10.41	16.31	1.14	19.77	12.26	2.56
42600.00	17.74	48.30	-5.87	-10.66	16.56	1.15	19.72	12.72	2.52
43000.00	17.75	47.70	-6.19	-11.85	16.28	1.15	19.67	12.36	2.48
43500.00	17.64	47.19	-6.36	-13.23	16.08	1.17	19.19	11.72	2.39
44000.00	17.18	47.30	-5.70	-13.39	16.26	1.21	19.24	11.55	2.50
44500.00	16.50	47.28	-4.71	-11.73	15.60	1.24	19.06	11.45	2.73
45000.00	15.83	47.50	-4.20	-10.11	15.81	1.24	19.98	11.20	3.02

Typical Performance Data

Definitions:

Input Return Loss = -S11 (dB)

Gain(Power Gain) = S21 (dB)

Reverse Isolation = -S12 (dB)

Output Return Loss = -S22 (dB)

TEST CONDITIONS: VDD = +2.75V, IDD = 82mA @ Temperature = +85°C

FREQ	Gain	Isolation	Input Return Loss	Output Return Loss	Stability		IP-3 Output	1dB Comp. Output	Noise Figure
					K	Measure			
(MHz)	(dB)	(dB)	(dB)	(dB)	K	Measure	(dBm)	(dBm)	(dB)
26000.00	20.75	59.52	-9.00	-9.19	45.50	0.99	19.12	10.11	3.23
26500.00	20.56	59.19	-8.58	-9.23	44.39	1.00	19.77	10.10	3.30
27000.00	20.46	58.82	-8.31	-9.41	42.93	1.02	19.70	10.01	3.33
27400.00	20.46	58.55	-8.35	-9.74	42.15	1.03	19.00	10.03	3.36
27800.00	20.48	60.10	-8.53	-10.22	51.44	1.03	19.14	10.18	3.35
28200.00	20.54	58.90	-8.84	-10.83	45.85	1.04	20.73	10.17	3.34
28600.00	20.63	59.19	-9.28	-11.44	48.35	1.04	19.49	10.07	3.35
29000.00	20.72	58.52	-9.80	-12.14	45.76	1.04	20.16	10.15	3.27
29400.00	20.76	57.88	-10.36	-12.69	43.25	1.03	19.49	10.19	3.33
29800.00	20.75	58.28	-10.63	-12.96	46.00	1.03	19.77	10.23	3.31
30200.00	20.75	58.32	-10.66	-12.89	46.26	1.03	19.40	10.29	3.42
30600.00	20.78	57.30	-10.49	-12.70	40.94	1.03	19.63	10.21	3.44
31000.00	20.88	57.02	-10.14	-12.37	38.86	1.03	19.26	10.32	3.47
31400.00	20.97	56.32	-9.70	-12.00	34.89	1.04	18.95	10.16	3.52
31800.00	21.17	55.68	-9.31	-12.00	31.60	1.05	18.42	9.90	3.53
32200.00	21.35	54.96	-9.16	-12.27	28.50	1.05	18.65	10.24	3.59
32600.00	21.59	53.72	-9.31	-12.59	24.40	1.05	19.21	10.56	3.59
33000.00	21.74	53.19	-9.65	-13.27	23.03	1.05	19.13	10.50	3.61
33400.00	21.88	52.32	-10.29	-13.97	21.07	1.05	19.53	10.60	3.57
33800.00	21.95	51.68	-11.07	-14.66	19.88	1.04	19.59	10.67	3.55
34200.00	21.95	51.08	-12.06	-15.17	19.02	1.03	19.13	10.64	3.50
34600.00	21.81	50.87	-12.83	-15.37	19.14	1.02	18.58	10.67	3.51
35000.00	21.61	50.57	-13.14	-15.21	19.10	1.02	19.32	10.49	3.48
35400.00	21.35	50.37	-12.90	-14.85	19.22	1.02	19.39	10.59	3.57
35800.00	21.02	50.50	-12.21	-14.50	20.08	1.02	19.60	10.67	3.62
36200.00	20.73	50.71	-11.47	-14.04	21.03	1.03	20.27	10.80	3.68
36600.00	20.34	50.42	-10.73	-13.87	20.83	1.04	20.94	10.77	3.73
37000.00	20.06	50.54	-10.12	-13.81	21.56	1.05	20.01	10.54	3.83
37400.00	19.82	50.64	-9.68	-13.71	22.15	1.06	19.66	10.61	3.87
37800.00	19.53	50.62	-9.24	-13.51	22.54	1.07	19.86	10.63	3.92
38200.00	19.26	50.65	-9.01	-13.04	23.17	1.07	20.61	10.68	3.97
38600.00	18.90	50.73	-8.84	-12.63	24.17	1.07	19.66	10.76	4.02
39000.00	18.61	50.50	-8.86	-12.15	24.46	1.06	19.66	10.50	4.02
39400.00	18.31	50.47	-9.02	-11.78	25.37	1.05	20.79	10.47	4.05
39800.00	18.12	50.01	-9.14	-11.62	24.79	1.05	19.79	10.40	4.00
40200.00	18.00	50.18	-9.10	-11.69	25.64	1.05	19.57	10.25	4.03
40600.00	17.84	49.94	-8.86	-11.89	25.25	1.06	20.00	10.46	4.03
41000.00	17.68	50.12	-8.40	-12.08	25.97	1.07	19.89	10.43	4.01
41400.00	17.42	50.10	-7.85	-12.36	26.19	1.09	20.60	10.47	4.07
41800.00	17.13	51.04	-7.26	-12.70	29.62	1.12	20.53	10.59	4.03
42200.00	16.80	50.88	-6.89	-12.77	29.78	1.14	19.93	10.61	4.12
42600.00	16.39	49.95	-6.58	-12.68	27.49	1.15	19.68	10.87	4.16
43000.00	16.09	49.77	-6.42	-12.70	27.72	1.16	19.74	10.46	4.22
43500.00	15.78	49.24	-6.37	-12.46	27.02	1.16	19.46	9.93	4.16
44000.00	15.41	49.25	-6.31	-12.29	28.07	1.16	19.42	9.90	4.19
44500.00	15.07	48.49	-6.12	-12.07	26.41	1.16	19.60	9.80	4.37
45000.00	14.66	48.18	-6.01	-11.84	26.56	1.17	20.59	9.51	4.31

Typical Performance Data

Definitions:

Input Return Loss = -S11 (dB)

Gain(Power Gain) = S21 (dB)

Reverse Isolation = -S12 (dB)

Output Return Loss = -S22 (dB)

TEST CONDITIONS: VDD = +3V, IDD = 83mA @ Temperature = +85°C

FREQ	Gain	Isolation	Input Return Loss	Output Return Loss	Stability		IP-3 Output	1dB Comp. Output	Noise Figure
					K	Measure			
(MHz)	(dB)	(dB)	(dB)	(dB)	K	Measure	(dBm)	(dBm)	(dB)
26000.00	20.74	60.01	-8.99	-9.27	48.30	0.99	19.40	10.67	3.28
26500.00	20.56	59.27	-8.58	-9.31	44.91	1.01	19.78	10.64	3.35
27000.00	20.47	59.63	-8.32	-9.49	47.28	1.02	19.69	10.57	3.32
27400.00	20.47	59.22	-8.36	-9.84	45.68	1.03	19.08	10.60	3.37
27800.00	20.49	58.89	-8.52	-10.32	44.82	1.04	19.29	10.79	3.35
28200.00	20.55	58.72	-8.84	-10.94	45.00	1.04	19.99	10.70	3.36
28600.00	20.64	58.56	-9.28	-11.56	45.02	1.04	19.27	10.64	3.38
29000.00	20.72	58.63	-9.81	-12.27	46.40	1.04	19.70	10.69	3.39
29400.00	20.76	58.49	-10.36	-12.82	46.52	1.04	18.98	10.64	3.36
29800.00	20.75	57.96	-10.62	-13.09	44.40	1.03	19.13	10.83	3.40
30200.00	20.74	58.47	-10.65	-13.02	47.16	1.03	19.11	10.92	3.45
30600.00	20.76	57.74	-10.48	-12.81	43.17	1.03	19.43	10.83	3.45
31000.00	20.85	57.77	-10.12	-12.48	42.53	1.04	19.17	10.94	3.53
31400.00	20.93	56.03	-9.68	-12.09	33.91	1.04	18.71	10.80	3.54
31800.00	21.12	56.12	-9.28	-12.09	33.44	1.05	18.45	10.47	3.57
32200.00	21.30	55.28	-9.13	-12.35	29.72	1.06	19.56	10.71	3.64
32600.00	21.53	54.08	-9.27	-12.69	25.60	1.06	18.61	11.02	3.61
33000.00	21.68	53.41	-9.61	-13.39	23.79	1.06	18.58	10.99	3.65
33400.00	21.80	52.42	-10.23	-14.10	21.49	1.05	18.84	11.07	3.61
33800.00	21.87	51.67	-11.01	-14.82	20.04	1.04	18.85	11.16	3.58
34200.00	21.85	51.25	-11.99	-15.35	19.63	1.03	18.80	11.14	3.54
34600.00	21.70	51.16	-12.76	-15.55	20.04	1.02	19.12	11.17	3.55
35000.00	21.50	51.14	-13.07	-15.40	20.67	1.02	19.34	11.04	3.55
35400.00	21.23	50.82	-12.83	-15.03	20.51	1.02	18.97	11.13	3.61
35800.00	20.90	50.40	-12.15	-14.67	20.13	1.02	19.25	11.18	3.64
36200.00	20.61	50.73	-11.41	-14.21	21.38	1.03	20.12	11.30	3.72
36600.00	20.22	50.80	-10.68	-14.03	22.06	1.04	19.90	11.34	3.83
37000.00	19.95	50.56	-10.08	-13.99	21.90	1.06	20.22	11.18	3.89
37400.00	19.72	50.64	-9.66	-13.90	22.45	1.06	19.39	11.25	3.94
37800.00	19.45	51.22	-9.23	-13.72	24.44	1.07	19.31	11.21	3.99
38200.00	19.19	50.97	-9.00	-13.24	24.28	1.07	19.46	11.26	4.04
38600.00	18.84	50.97	-8.83	-12.85	25.09	1.07	19.91	11.38	4.11
39000.00	18.56	50.88	-8.83	-12.38	25.74	1.07	20.10	11.14	4.10
39400.00	18.27	50.95	-8.99	-12.01	26.99	1.06	19.63	11.07	4.08
39800.00	18.08	50.02	-9.12	-11.86	25.00	1.05	19.64	11.04	4.06
40200.00	17.97	49.96	-9.10	-11.97	25.18	1.05	19.23	10.87	4.07
40600.00	17.83	49.88	-8.88	-12.19	25.26	1.06	19.55	11.14	4.05
41000.00	17.69	50.41	-8.43	-12.42	27.00	1.08	20.46	11.04	4.04
41400.00	17.45	50.81	-7.88	-12.73	28.48	1.10	20.20	11.08	4.08
41800.00	17.18	50.82	-7.27	-13.08	28.87	1.13	19.61	11.15	4.12
42200.00	16.88	50.59	-6.90	-13.16	28.71	1.14	20.31	11.22	4.10
42600.00	16.49	50.15	-6.57	-13.08	27.95	1.16	20.15	11.44	4.23
43000.00	16.21	49.68	-6.39	-13.11	27.15	1.17	19.51	11.10	4.25
43500.00	15.93	49.50	-6.32	-12.86	27.43	1.17	19.47	10.57	4.18
44000.00	15.58	49.17	-6.24	-12.69	27.29	1.17	19.40	10.50	4.28
44500.00	15.26	48.67	-6.05	-12.43	26.37	1.17	19.41	10.40	4.08
45000.00	14.86	48.24	-5.92	-12.16	26.06	1.18	19.44	10.14	4.35

Typical Performance Data

Definitions:

Input Return Loss = -S11 (dB)

Gain(Power Gain) = S21 (dB)

Reverse Isolation = -S12 (dB)

Output Return Loss = -S22 (dB)

TEST CONDITIONS: VDD = +3.25V, IDD = 84mA @ Temperature = +85°C

FREQ	Gain	Isolation	Input Return Loss	Output Return Loss	Stability		IP-3 Output	1dB Comp. Output	Noise Figure
					K	Measure			
(MHz)	(dB)	(dB)	(dB)	(dB)	K	Measure	(dBm)	(dBm)	(dB)
26000.00	20.71	59.72	-8.99	-9.34	46.97	1.00	19.05	11.06	3.30
26500.00	20.53	59.59	-8.58	-9.39	46.84	1.01	19.60	11.01	3.37
27000.00	20.45	59.33	-8.32	-9.58	45.89	1.02	19.62	11.00	3.37
27400.00	20.45	58.22	-8.36	-9.94	40.87	1.03	19.49	11.03	3.44
27800.00	20.47	58.37	-8.53	-10.42	42.37	1.04	19.31	11.22	3.39
28200.00	20.54	59.26	-8.84	-11.05	48.05	1.04	19.48	11.05	3.40
28600.00	20.63	59.54	-9.29	-11.68	50.62	1.04	19.17	11.02	3.42
29000.00	20.71	58.70	-9.81	-12.39	46.96	1.04	19.74	11.07	3.36
29400.00	20.74	59.05	-10.35	-12.95	49.77	1.04	19.30	10.92	3.39
29800.00	20.73	58.51	-10.61	-13.21	47.48	1.04	19.00	11.22	3.48
30200.00	20.72	58.70	-10.63	-13.14	48.62	1.03	19.30	11.39	3.52
30600.00	20.72	57.89	-10.45	-12.92	44.15	1.03	19.21	11.29	3.49
31000.00	20.80	57.99	-10.09	-12.58	43.92	1.04	19.22	11.39	3.56
31400.00	20.87	56.51	-9.65	-12.18	36.15	1.04	19.00	11.27	3.56
31800.00	21.06	56.48	-9.25	-12.18	35.11	1.05	18.54	10.94	3.64
32200.00	21.23	55.22	-9.10	-12.44	29.78	1.06	18.98	11.17	3.68
32600.00	21.45	54.04	-9.24	-12.78	25.73	1.06	18.93	11.41	3.64
33000.00	21.60	53.44	-9.57	-13.51	24.10	1.06	18.68	11.35	3.70
33400.00	21.71	53.18	-10.19	-14.23	23.71	1.05	18.12	11.47	3.66
33800.00	21.76	52.40	-10.95	-14.97	22.08	1.04	19.21	11.59	3.62
34200.00	21.73	51.51	-11.93	-15.53	20.49	1.03	19.02	11.57	3.58
34600.00	21.57	51.47	-12.69	-15.74	21.08	1.02	18.64	11.59	3.57
35000.00	21.37	51.06	-13.00	-15.59	20.81	1.02	19.54	11.48	3.60
35400.00	21.09	51.05	-12.77	-15.22	21.42	1.02	19.77	11.60	3.63
35800.00	20.76	50.93	-12.09	-14.84	21.76	1.03	19.19	11.63	3.68
36200.00	20.47	50.95	-11.35	-14.36	22.28	1.03	20.05	11.70	3.76
36600.00	20.09	51.12	-10.62	-14.20	23.26	1.05	19.43	11.82	3.83
37000.00	19.83	50.93	-10.04	-14.17	23.18	1.06	19.70	11.68	3.89
37400.00	19.60	51.19	-9.63	-14.09	24.28	1.07	19.90	11.74	4.01
37800.00	19.34	51.25	-9.21	-13.92	24.87	1.08	19.17	11.74	4.04
38200.00	19.10	51.24	-9.00	-13.46	25.38	1.08	20.17	11.78	4.08
38600.00	18.77	51.14	-8.83	-13.08	25.85	1.08	19.54	11.92	4.09
39000.00	18.50	50.96	-8.82	-12.60	26.23	1.07	19.25	11.65	4.12
39400.00	18.21	50.64	-8.96	-12.25	26.27	1.06	19.99	11.59	4.12
39800.00	18.03	50.52	-9.09	-12.11	26.71	1.06	19.60	11.52	4.11
40200.00	17.93	50.25	-9.09	-12.25	26.29	1.06	19.59	11.40	4.10
40600.00	17.80	50.18	-8.89	-12.50	26.35	1.07	20.30	11.62	4.09
41000.00	17.68	49.98	-8.45	-12.75	25.86	1.08	19.57	11.51	4.07
41400.00	17.46	50.71	-7.90	-13.10	28.30	1.10	20.14	11.55	4.17
41800.00	17.21	51.07	-7.29	-13.47	29.74	1.13	19.89	11.62	4.14
42200.00	16.93	50.78	-6.90	-13.56	29.29	1.15	20.17	11.72	4.23
42600.00	16.56	50.10	-6.56	-13.48	27.65	1.16	19.86	11.96	4.28
43000.00	16.31	49.52	-6.37	-13.52	26.43	1.17	20.57	11.57	4.26
43500.00	16.06	49.12	-6.27	-13.26	25.90	1.17	19.35	11.03	4.23
44000.00	15.73	49.19	-6.18	-13.07	26.87	1.18	19.42	10.98	4.31
44500.00	15.43	48.32	-5.98	-12.78	24.82	1.18	19.77	10.75	4.25
45000.00	15.04	48.39	-5.84	-12.48	25.90	1.19	20.04	10.57	4.46

Typical Performance Curves

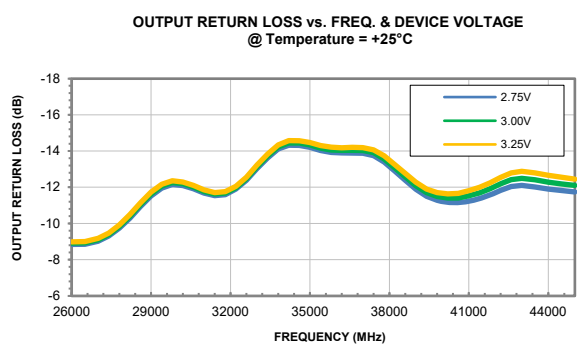
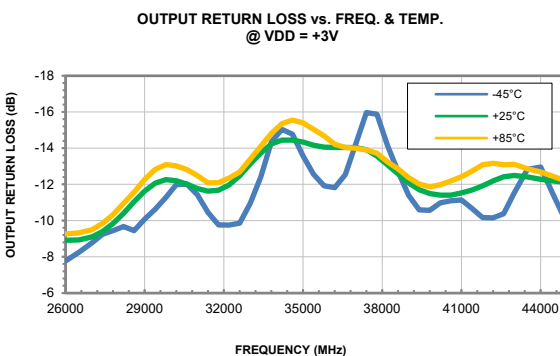
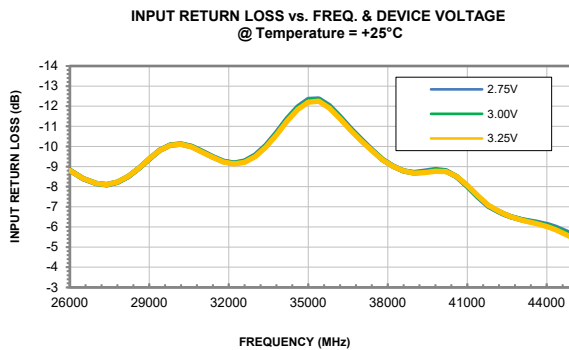
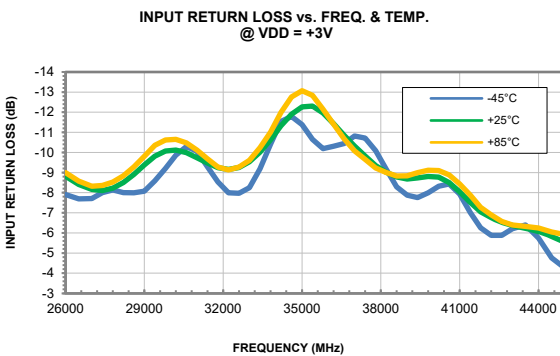
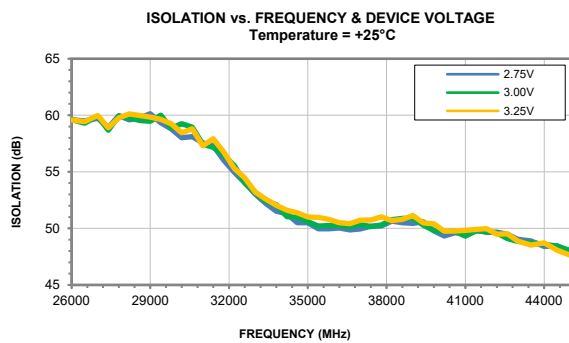
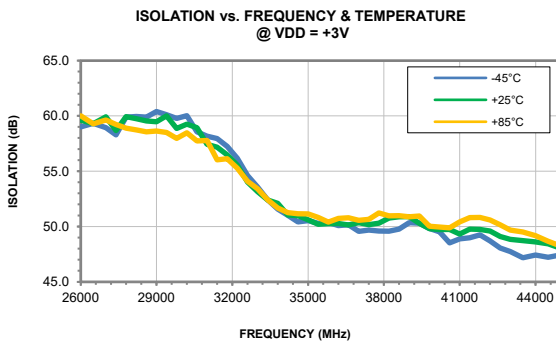
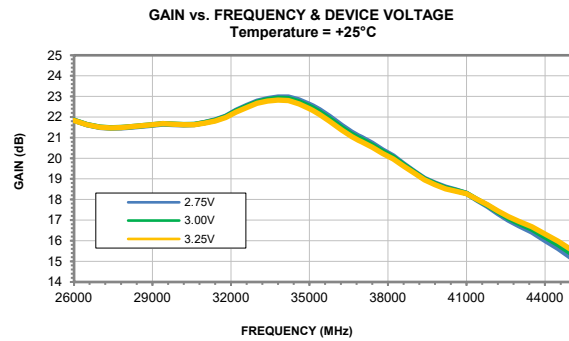
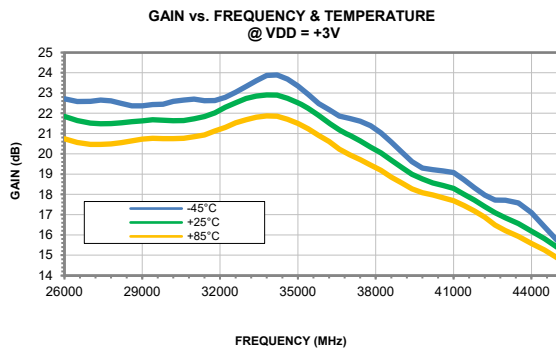

Typical Performance Curves

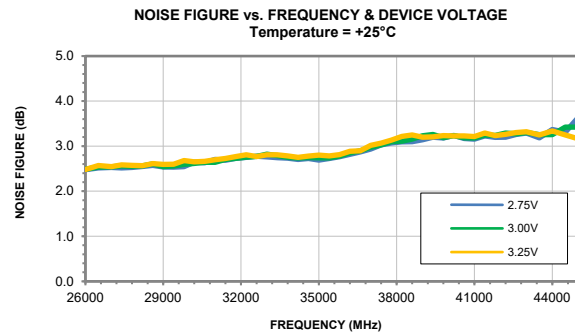
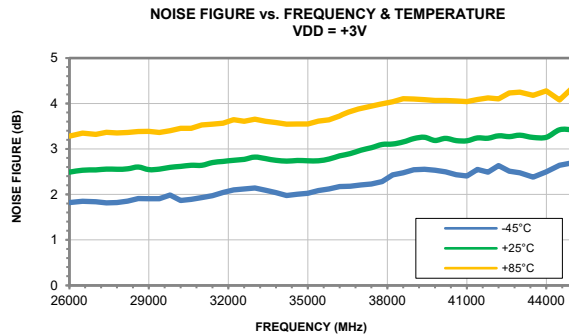
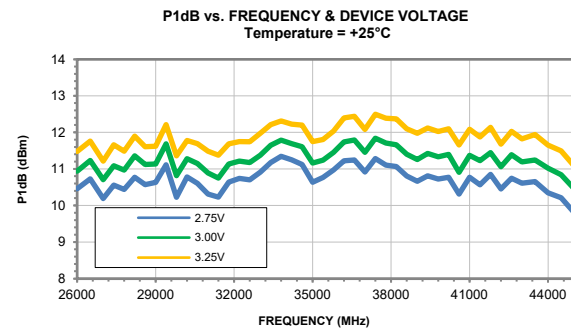
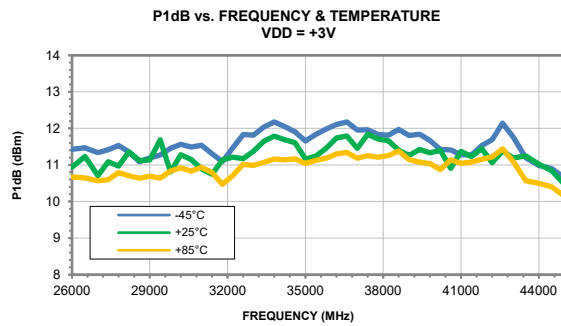
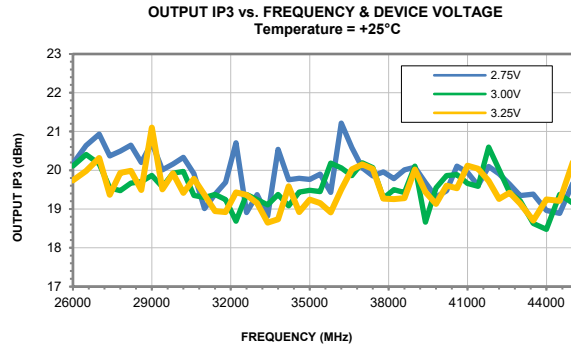
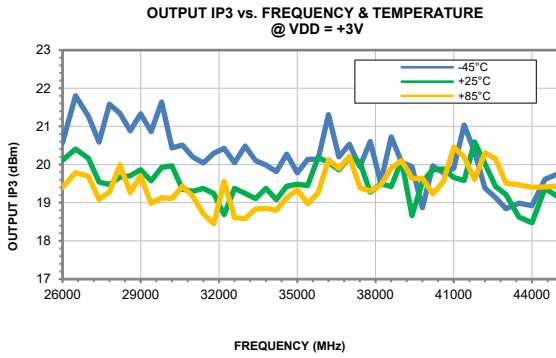



All Mini-Circuits products are manufactured under exacting quality assurance and control standards, and are capable of meeting published specifications after being subjected to any or all of the following physical and environmental test.

Specification	Test/Inspection Condition	Reference/Spec
Operating Temperature	-40° to 85° C or -40° to 105° C or -55° to 105° C Ambient Environment	Refer to Individual Model Data Sheet
Storage Environment	20° to 35° C and 40 to 60% humidity (In Factory Shipped Package)	Individual Model Data Sheet